



Operation Manual

ANSI SAIA A92.20-2021

S1932E/S1932 II /S1932E II

S2632E/S2632 II /S2632E II

SS2632E

S2646E/S2646 II /S2646E II

S3246E/S3246 II /S3246E II

S4046E/S4046 II /S4046E II

S4650E/S4650 II /S4650E II

**Mobile Elevating
Work Platforms**

PART No. OM-2537050496

Original Instructions

Original Instructions

Thank you for choosing to use this Mobile Elevating Work Platform from the company, All models are designed and manufactured according to ANSI SAIA A92.20-2021, All dealers, owners, users, operators, lessors, lessees, and brokers to comply with appropriate section(s) of applicable A92 standards.

This manual is a guide for safe and proper operation and maintenance of the machine, which introduces maintenance and operation herein.

We sincerely hope that you will read through this manual before attempting to operate the machine for the first time and before repairing and maintaining the machine, and that you will master the operation and maintenance described therein.

The information contained in this manual is correct at the time of publication. The Company has endeavored to deliver the highest degree of accuracy possible. However, continuous improvement of our product is the Company's policy. Therefore, product specifications are subject to change without notice.

Due to the impossibility of foreseeing all possible hazards, therefore, it is not possible to include all safety precautions in this manual and the machine's safety precautions in this manual and the machine's safety instructions. If some operations that are not recommended in this manual, you must ensure that you and others are safe and will not damage the machine. If the security of certain operations cannot be determined, please call the company industries or dealer service center.

The precautions for operation and maintenance contained in this manual are only applicable when the machine is used for the specified use. If the machine is used within the scope not listed in this manual, our company will not accept any safety responsibility, which is borne by the user and operator in such operations.

Any prohibited operations in this manual shall not be performed.

This manual should always be placed in the designated location for read. This manual is part of the machine, when the ownership or use right of the machine is transferred, please hand over this manual together. If the manual is lost, damaged or illegible, please replace it promptly.

The copyright of this manual this manual is authorized to the company and it cannot be copied or reprinted without the company's written permission.

2025-12 Version 1 Printed 1

LGMG DE MEXICO, S.A. DE C.V.

Add: Roots Industrial Technologies, Calle Principal 113 y 115, 66700, Marin, N.L., Mexico.

Tel: 86-0531-67601108
Service Tel: 86-0531-67605016

Fax: 86-0531-67601108
Web: www.lgmg.com.cn



Contents

Contents	I
Chapter 1 Safety	1
1.1 Description	2
1.2 Maintenance of Safety Signs and Decals	2
1.3 Workstation Safety	2
1.4 Battery Safety.....	7
1.5 Lock After Each Use	8
Chapter 2 Machine Nomenclature	9
Chapter 3 Controls.....	11
3.1 Ground Controls	11
3.2 Platform Controls.....	12
Chapter 4 Pre-Operation Inspection.....	15
4.1 Basic Principles	15
4.2 Pre-Operation Inspection	15
Chapter 5 Workstation Inspection.....	17
5.1 General Information	17
5.2 Workstation Inspection	17
Chapter 6 Function Test	19
6.1 General Information.....	19
6.2 Function Test	19
6.3 Tests from the Ground Controls.....	19
6.4 Test the Emergency Stop Switch	19
6.5 Test the Up/Down Functions.....	20
6.6 Emergency Lowering Function Test	20
6.7 Platform Controller Test.....	20
6.8 Horn Test	20



6.9 Lift Function and Function Enable Switch Test	21
6.10 Steering Test	21
6.11 Driving and Braking Function Test	22
6.12 Driving Function Test	22
6.13 Operation of Tilt Sensor Test.....	22
6.14 Pothole Guard Test.....	23
Chapter 7 Operating Instructions	25
7.1 General Information	25
7.2 Emergency Stop.....	25
7.3 Emergency Lowering.....	26
7.4 Operation from the Ground Controls	26
7.5 Operation from the Platform Controls	27
7.6 Using Platform Controller to Drive the Machine on the Ground.....	29
7.7 Driving on a Slope	30
7.8 Using the Safety Prop.....	30
7.9 How to Stow the Guardrail	31
7.10 How to Erect the Guardrail.....	31
7.11 Extending and Retracting the Extending Platform Deck.....	32
7.12 Power Supply Switch.....	32
7.13 Error Codes	33
Chapter 8 Transport and Lifting Instructions	39
8.1 Releasing the Brake.....	39
8.2 Transport Safety.....	41
8.3 Loading the Machine with a Forklift	42
8.4 Lifting Precautions	43
8.5 Parking and Storage	43
Chapter 9 Decals and Warning Labels	45





Chapter 10 Specifications 113
 10.1 Hydraulic Oil Specifications..... 151





Chapter 1 Safety

 **DANGER:** Death or severe injuries can be caused if the instructions and safety regulations in this manual are not followed.

 **WARNING:** Operation of the machine is forbidden, unless:

The safe operation rules of the machine are understood and practiced.

Dangerous conditions are avoided. All safety regulations shall be acknowledged and understood before the next step.

The pre-operation inspection is always completed before operation of the machine.

The function test is always made before operation of the machine.

The workstation is inspected and tested.

The machine is used for its design purposes.

The manufacturer's instruction and safety regulations-the safe operation manuals and machine labels, shall be read, comprehended and followed.

The safety regulations for user and the site regulations shall be read, comprehended and followed.

All applicable laws and regulations of the

government are read, understood and followed.

The appropriate training on safe operation of machine has been completed.

 **NOTICE:** Classification of hazards

The meanings of symbols, color codes and characters of LGMG's products are as follows:

Security warning symbol: Are used for warning of potential personal injuries. Observe all safety instructions below these signs, to avoid situations causing potential personal injury and death.



Red: Signifies dangerous situations. If not avoided, will result in personal death or severe injury.



Orange: Signifies dangerous situations. If not avoided, may result in personal death or severe injury.





Yellow: Signifies dangerous situations. If not avoided, may result in minor or intermediate personal injury.



Blue: Signifies dangerous situations. If not avoided, property loss or damage can occur.

1.1 Description

This machine is a mobile elevating work platform, consisting of a work platform on a scissor mechanism.

1.2 Maintenance of Safety Signs and Decals

Replace any missed or damaged safety signs or decals. If necessary, use mild soap and water to clean safety signs. Do not use solvent-based cleaners because they may damage the safety sign material.

1.3 Workstation Safety



Electrocution Danger

This machine is not electrically insulated and does not provide protection from touching or getting close to electrical power lines. Please keep a safe distance from power lines and power equipment according to the applicable laws and

regulations. Refer to the following table for safe approach distances for power lines.

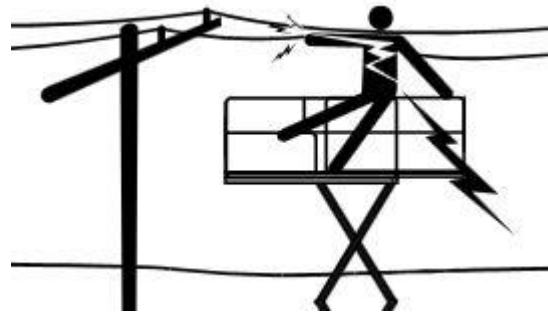

Minimum Safe Approach Distance

Voltage	Required Clearance
0 to 50KV	3.05m
50KV to 200KV	4.6m
200KV to 350KV	6.10m
350KV to 500KV	7.62m
500KV to 750KV	10.67m
750KV to 1000KV	13.72m

- Always take into account the influence of strong or gusty winds on the platform and also on the swinging of the electrical power lines.
- Stay away from the machine if it contacts a live electric wire. Do not touch or operate the machine from the ground or the platform before cutting off the power supply.
- Do not operate the machine in inclement weather.
- Do not use the machine as a ground for welding. This could damage electrical



components on the machine.

- Do not touch the battery charger when charging the batteries.

Tip Over Hazard

The personnel, equipment, and material on the platform shall not exceed the maximum bearing capacity of the platform and the extending platform. Refer to Chapter 10 – Specifications for model capacities.

- 1) The platform can only be elevated on flat, solid ground.

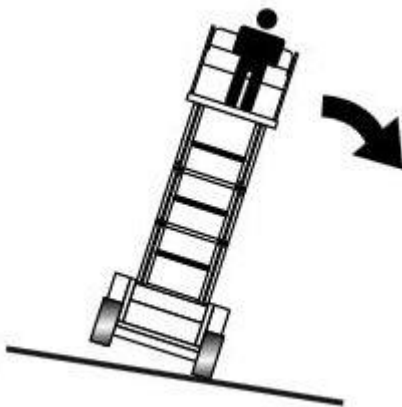

- 2) With the platform raised, do not driver over the maximum allowable value indicated in the specification sheet.
- 3) Do not use the tilt alarm as a level indicator. The tilt alarm only sounds when the machine is severely tilted.
- 4) If the tilt alarm sounds: Lower the platform and move the platform to flat, solid ground. If the tilt alarm sounds when elevating the

platform, lower the platform immediately.

- 5) If the machine is used outdoors, do not elevate the platform when wind speed is above 12.5 m/s. If wind speed exceeds the limit after elevating the platform, immediately lower the platform and stop all machine operation.
- 6) The ambient temperature range for use of this machine is -20°C to 40°C.
- 7) The relative humidity for use of this machine shall be no greater than 90% (at 20°C).
- 8) The allowable voltage fluctuation of the machine is $\pm 10\%$.
- 9) Do not increase the surface area of platform or load. Increasing the exposure area in wind will reduce the stability of machine.
- 10) When the platform is caught, stuck or blocked by a nearby item and is unable to normally move, do not try to release the platform using the platform controller. All personnel must be removed from the platform before releasing the platform using the ground controller.
- 11) Be cautious and lower drive speed when the machine is fully lowered and driving on an uneven road, a gravel road, an unstable or smooth surface, near a hole, or on a slope.



12) Do not drive in high-speed descending any slope.



CAUTION: Make sure slow speed (turtle)

is selected before descending any slope.

13) Do not drive the machine on any uneven or unstable roads or in any other dangerous conditions, when the platform is elevated.

14) Do not push off or pull toward any object outside of the platform.

15) Do not use the machine as a crane.

16) Do not place, anchor, or suspend any load from any part of the machine.

17) Do not push the machine or other items using the platform.

18) Do not operate the machine when the chassis tray is pulled out.

19) Do not lean the platform against any nearby structure or wall.

20) Do not modify or limit the use of the limit switch.

21) Do not bind or tie the platform to a nearby structure or wall.

22) Do not place the load outside the platform guard rail.

23) Do not modify or change the aerial work platform without the written consent of the manufacturer. Installing an additional device

used for carrying tools or other materials on the platform, pedal, or guard rail will increase platform weight, platform surface area, and load.

24) Do not modify or damage any safety or stability related parts of the machine.

25) Do not replace any key stability-related parts with those with different weights or specifications.

26) It is forbidden to use a battery weighing less than the original battery. The battery installed on the chassis is used as counterweight and is vital for the stability of machine. Every battery has a different weight.

27) Do not place the steps, ladders, or scaffolding in the platform or lean them against any part of the machine.

28) Tools and materials, evenly distributed and able to be safely moved by the operator in the platform, can be carried in the platform only.

29) Do not use the machine on a movable surface or vehicle.

30) Keep all tires in good condition and appropriately tighten the lug nuts.



Crushing Hazards

● **Do not place arms, hands, or fingers in**





any position where there is a hazard of potential crushing by the machine's scissors.

- When the machine is being driven from the ground using the controller, use good judgment and carefully plan the travel path. Keep a safe distance between the operator, machine and any fixed objects, walls, or buildings.



Hazards When Operating on a Slope

Do not drive the machine on a slope that exceeds the slope and side slope rating of the machine. The rated value of slope is applicable to a stowed machine.

Maximum slope rating, stowed position: 	25%(14°)
Maximum side slope rating, stowed position: 	25%(14°)

Note: Slope rating is subject to ground conditions and adequate traction.



Falling Hazards

- We recommend each occupant of the platform wear personal fall protection

equipment (PFPE) and attach the lanyards to the provided anchorage points, with only one lanyard per designated anchorage point. PFPE and its use shall be in accordance with the PFPE manufacturer's instructions, applicable government regulations, employer and job site safety rules.



- Do not climb on or sit on the guard rail of the platform. Firmly stand on the platform floor at all times.

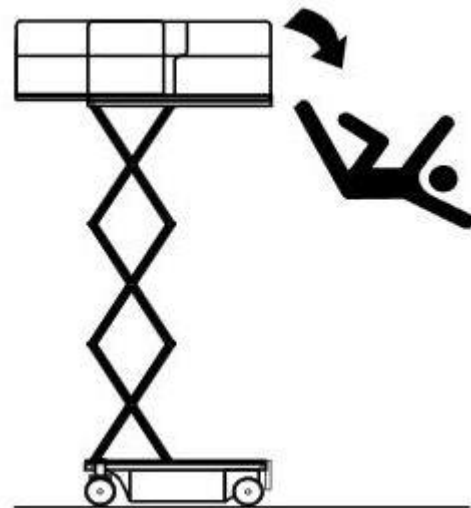

- Do not climb down the platform scissors when the machine is elevated.
- Keep the platform floor free from debris.



- Shut down the platform door before operation.
- Do not operate the machine if the guard rail is not correctly installed.
- Do not enter or exit the platform unless the machine is in the stowed position.



Crash Hazards

- Pay attention to any items or obstacles within the machine's sight line and in any blind spots when starting or running the machine.
- Pay attention to the position of the extending platform when moving the machine.
- Check the workstation to avoid any overhead barriers or other possible hazards in the work site.



- Pay attention to any crushing hazards when holding the guard rail of the platform.

- The operator must follow the manufacturer's service rules for personal protection equipment, the service rules for the workstation, and the laws and regulations made by the local government.
- Observe and follow the traveling arrow and the turning direction arrows on the platform controller and the platform's label and nameplate.
- Do not operate the machine on the line of any crane or movable overhead machine, unless the crane controller is locked and/or the potential bump prevention measure is taken.
- Dangerous driving or careless operation when running the machine are strictly prohibited.
- The platform can be lowered only when there are no personnel or barriers below the platform.
- Limit travel speed according to ground conditions, traffic, road grade, personnel position, or any other possible bump factors.



Component Damage Hazards

- Do not charge the batteries with anything



more than a 24V battery charger.

- Do not use the machine as a ground for welding. This could cause damage to the electrical components on the machine.



Explosion and Fire Hazards

- Do not operate or charge the machine in a location with a potential for inflammable or explosive gas or particles.



Machine Damage Hazards

- Do not use a damaged or malfunctioning machine.
- Make a complete operational and function check before each shift. Attach an out of service tag on a damaged or malfunctioning machine immediately and stop all operations.
- Be sure to perform all maintenance and operation according to the instructions in this manual.
- Be sure to keep all labels and decals at the appropriate locations. Replace any that are not legible.
- Be sure to keep this manual in the manual box of the platform.



Personal Injury Hazards

- Do not operate the machine if it is leaking hydraulic oil. Leaking hydraulic oil under

pressure can pierce or burn skin.

- It is forbidden to carry out maintenance work when the equipment is electrically charged or the hydraulic system is under pressure.
- Severe injury may result if any component below the cover is touched by mistake. Only trained technicians can perform maintenance to the components under the cover. The operator shall only perform maintenance before the pre-operation inspection. Be sure to keep all compartments closed and locked during operation of the machine.

1.4 Battery Safety



Combustion Hazards

- The battery contains acid. Wear protective clothing and safety goggles when performing maintenance on the battery.
- Take measures to prevent acid from overflowing out of the battery or being touched. Neutralize the overflowed acid material from the battery with soda and water.



Explosion Danger

- Keep the battery away from any sparks or open flames. The battery can release an



explosive gas.

- Do not touch the battery terminal or the cables with any tool that may cause a spark.
- When the vehicle stops for a long time, it is necessary to turn off the main power switch.

barriers or heavy traffic.

- 2) Lower the platform.
- 3) Rotate the key switch to the “OFF” position and pull out the key, to avoid unauthorized use.
- 4) Charge the battery.



Component Damage Hazard

Do not charge the battery with more than a 24V battery charger.



Electrocution/Burn Hazards

- The battery charger can be connected to the grounded AC three-wire power socket.
- On a daily basis, check to see if the wire cable, electric cable and wiring are damaged. Replace the damaged items before the operation.
- Take measures to prevent electric shock from touching the battery terminals. When working on the electrical circuits, remove all jewelry and metallic objects. The battery charger can be connected to the grounded AC three-wire power socket.

1.5 Lock After Each Use

- 1) Choose a safe parking position which is solid and horizontal ground where there are no



Chapter 2 Machine Nomenclature

 **NOTICE:** This drawing shows an S1932E, but the nomenclature is common for all other models.

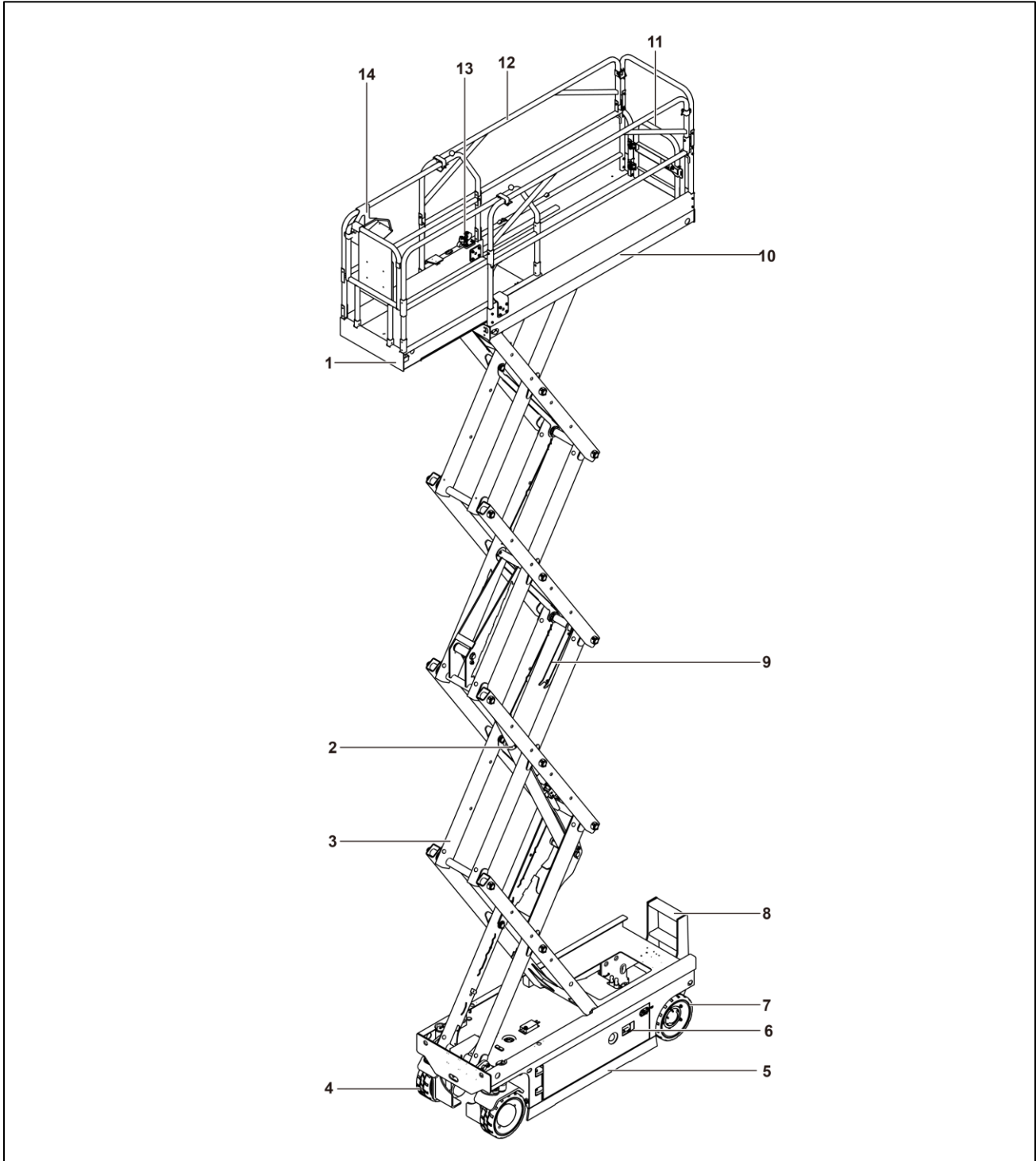



Operation Manual of Scissors Mobile Elevating Work Platform

No.	Name	No.	Name
1	Extending Platform	8	Ladder
2	Lift Cylinder	9	Safety Prop
3	Scissor Stack Arm	10	Main Work Platform
4	Steering Wheel	11	Platform Door
5	Pothole Protection Device	12	Guardrail
6	Charging Panel	13	Pedal
7	Non-steering Wheel	14	Platform Control Box



Chapter 3 Controls

3.1 Ground Controls

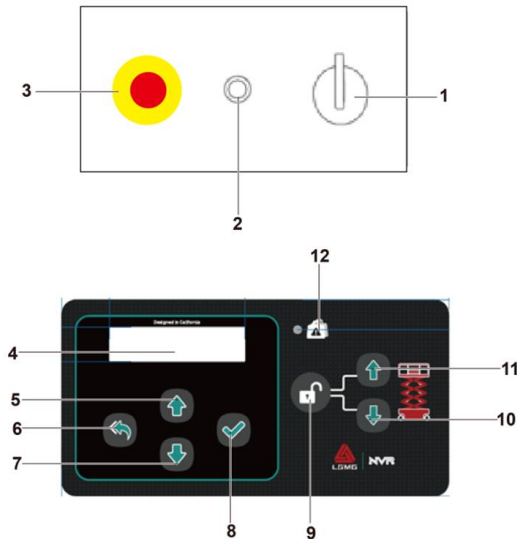

Fig. 3-1 Ground Control

1. Key Switch
2. Auto reset fuse (7A)
3. Emergency stop switch
4. Display
5. Menu up button
6. Menu escape button
7. Menu down button
8. Menu enter button
9. Lift function enable button
10. Platform down button
11. Platform up button
12. Platform overload indicator

3.1.1 Key Switch

The three-position key switch controls the power supply for the machine. When the switch is set to the left, the platform operation mode will be enabled; when the switch is set to the right position, the chassis operation mode will be

enabled; when the switch is set to the center position, the power to the machine will be off.



NOTICE

The key can be inserted or removed only when the switch is in the center position. Some machines are equipped with optional switches that allow the keys to be inserted or removed at all three positions.

3.1.2 Emergency Stop Switch

The power supply to the machine is disconnected when the emergency stop switch is pressed.



NOTICE: An emergency stop switch is installed on both the chassis and the platform controller. The two switches operate together in series. Normal operation can be performed when both switches are pulled out. The power supply will be cut off when either emergency stop switch is pressed.



3.2 Platform Controls

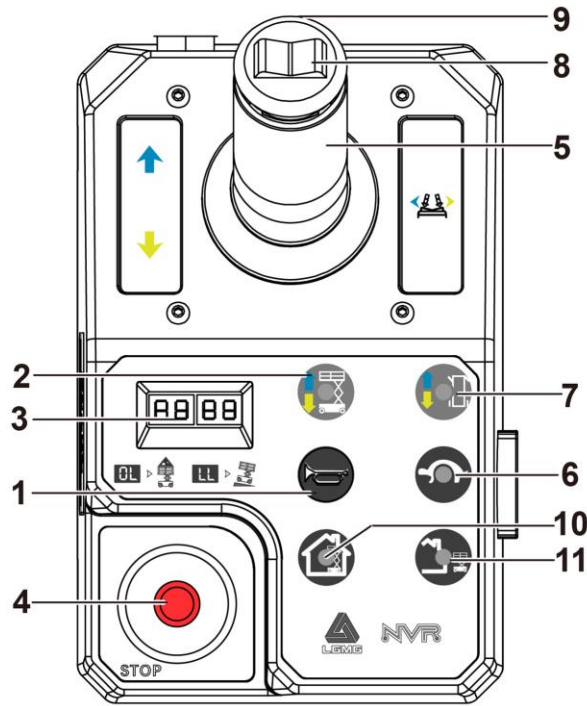

Fig. 3-2 Platform Control

1. Horn Button
2. Lift function button
3. Display
4. Emergency Stop Switch
5. Control Lever
6. Drive Speed Button
7. Drive Function Button
8. Steer Switch
9. Enabling Switch
10. Indoor mode button
11. Outdoor mode button

3.2.1 Horn Button

The horn will sound when this button is pressed, and will stop when the button is released.

Note: If the function is inactive for a period of time, the machine will time out and go into sleep mode. Activating the horn will awaken

the machine and activate the last function used.

3.2.2 Lift Function Button



Pressing this switch activates the lift function for the platform.

3.2.3 Display

The Display shows Diagnostic Fault Codes and battery status.

Data on the Display

Operating step	Displayed data
Power on but no moving	Battery capacity
Move forward or backward	Battery capacity
Lift up the platform	Battery capacity
Lower the platform	Battery capacity
A fault occurs	Error code
Chassis control mode	C H

3.2.4 Emergency Stop Switch

The power supply to the machine is disconnected when the emergency stop switch is pressed.



NOTICE: An emergency stop switch is installed on both the chassis and the platform controller. The switches operate together in series. Operation can be performed when both switches are pulled out. The power supply will be cut off when either emergency stop switch is pressed.



3.2.5 Drive/Lift Control Lever

Drive function:

After the enabling switch is pressed, the machine will move to the forward when the control lever is moved to the direction (front) indicated by the blue arrow, or to the backward when the control lever is moved to the direction (back) indicated by the yellow arrow.

Lift function:

After the enabling switch is pressed, the platform will raise when the control lever is moved to the forward, or lower when the control lever is moved to the backward.



NOTICE: When the platform is lowering, the lowering alarm will beep.



NOTICE: If using emergency lowering, the alarm will not beep.

3.2.6 Drive Speed Button



Press this button to active the slow drive function. The indicator light will be on when the slow drive is selected.

3.2.7 Drive Function Button



Pressing this button activates the drive function.

3.2.8 Steer Switch



After the drive function button and the enabling switch on the lever are pressed, the steer switch can be used to control the steering direction of the machine.

3.2.9 Enabling Switch

The driving, steering, lifting or lowering function can be activated only when the enabling switch on the lever is pressed.

3.2.10 Indoor mode Button



This function is applied uniformly across the machines equipped with indoor and outdoor lifting height.

- 1) Press this button, the indicator lamp will light up, and the indoor mode is enabled.
- 2) When the indoor mode is enabled, the lift will be allowed to set to the indoor maximum height. Refer to the specifications.
- 3) At the retracted state, the indoor/outdoor mode can be switched; at the lifting state, the indoor/outdoor mode cannot be switched.



- 4) The default mode is the one when the machine is turned off (Key switch off or emergency stop switch off).



WARNING: In case of indoor mode, it is prohibited to move the machine from indoors to outdoors.

3.2.11 Outdoor mode Button



This function is applied uniformly across the machines equipped with indoor and outdoor lifting height.

- 1) Press this button, the indicator lamp will light up, and the outdoor mode is enabled.
- 2) When the outdoor mode is enabled, the lift will be allowed to set to the outdoor maximum height. Refer to the specifications.
- 3) At the retracted state, the indoor/outdoor mode can be switched; at the lifting state, the indoor/outdoor mode cannot be switched.
- 4) The default mode is the one when the machine is turned off (Key switch off or emergency stop switch off).



Warning: In case of indoor mode, it is prohibited to move the machine from indoors to outdoors.



Chapter 4 Pre-Operation Inspection



WARNING: Operation of this machine is forbidden, unless the safe operation principles of the machine are understood and practiced.

- All dangerous conditions are avoided.
- The pre-operation inspection is always performed.



NOTICE: Ensure the workstation inspection is fully understood before proceeding to the next step.

- The workstation is inspected and checked.
- The function test is always made before operation.
- The machine is used for its designed purpose.

4.1 Basic Principles

- 1) The pre-operation inspection and routine maintenance are the responsibilities of the operator.
- 2) The pre-operation inspection is a visual process, which shall be performed daily by the operator before each work shift. The purpose of the inspection is to check the machine for any significant problems before performing the Function Test.

- 3) The pre-operation inspection can also be used for confirming if routine maintenance is required. The operator shall only perform routine maintenance as specified in this manual.
- 4) Check the list in the next page and check every item.
- 5) If any damage is found or any un-permitted change different to the delivery status is found, tag the controls and stop operation of the machine.
- 6) Repairs to the machine may only be made by a qualified service technician according to the manufacturer's requirements. After the required maintenance has been performed, the operator must carry out the pre-operation inspection again before the function test.

4.2 Pre-Operation Inspection

- 1) Ensure the manual is complete and legible. Keep it in the manual box on the platform.
- 2) Keep all labels clear and readable and place them appropriately. Go through the label.
- 3) Check for any hydraulic oil leakage and proper oil level. Go through the label.



- 4) Check for any battery fluid leakage and if the liquid level is suitable. Add distilled water, if required.
- 5) Inspect the entire machine for:
 - a) Cracks in welds or structural components.
 - b) Machine pitting or damage.
 - c) All structural members and other key components have no missing parts, related fasteners and pins are in the correct position, and properly tightened.
 - d) Install the guard rail, place the guard rail pin in place, and tighten the retaining bolts.
- 6) Check the following components for damage, proper installation, and any missing parts or unauthorized changes to components:
 - a) Battery pack and connections.
 - b) Electric element, wiring and cable.
 - c) Nuts, bolts, and all other fasteners.
 - d) Hydraulic hoses, connectors, cylinders, and valves.
 - e) All Indicator lamps and alarms.
 - f) Safety props.
 - g) Pothole guards.
 - h) Platform overload components (if equipped).
 - i) Scissor arm pins and fasteners.
 - j) Limit switches, alarms, and horn.
 - k) Drive motors.
 - l) Tires and wheels.
 - m) Slide blocks and liners.
 - n) Brake release components.
 - o) Ground straps.
 - p) Platform entry gate.
 - q) Platform control box.
 - r) Extending platform deck.
 - s) Keep the chassis battery tray and oil pump tray closed and locked. Engage the battery disconnect switch.



NOTICE: If the platform must be elevated to inspect any machine components, keep the safety prop in the correct position. Refer to Chapter 7 – Operating Instructions.



Chapter 5 Workstation Inspection



WARNING: Operation is forbidden

unless the following safe operating principles of the machine are understood and performed.

- 1) All dangerous work site conditions are avoided.
- 2) Pre-Operation Inspection has been completed.
- 3) The workstation has been inspected.



NOTICE: The workstation inspection

must be performed and proper operating procedures understood before the next step.

- 4) The function test has been performed.
- 5) The machine is used as described in this manual.

5.1 General Information

- 1) Using the Workstation Inspection procedures, the operator can determine if the safe operation of machine is possible from the workstation. The operator shall carry out this process before operating the machine from the workstation.
- 2) Understanding the hazards of the workstation are the responsibilities of the operator. Avoid these hazards while moving, delivering, or operating the machine.

5.2 Workstation Inspection

Be aware of the following hazards:

- 1) Sudden slopes, holes, or dips in the traveling surface.
- 2) Bumps, ground barriers, or debris on the ground.
- 3) Inclined plane.
- 4) Infirm or unsteady ground surface.
- 5) Overhead barriers and high-voltage power lines.
- 6) Dangerous location
- 7) Supporting surface unable to bear the load of the machine.
- 8) Wind and inclement weather.
- 9) Unauthorized personnel.
- 10) Other possible unsafe conditions.



This page left blank intentionally



Chapter 6 Function Test



WARNING: Operation is forbidden unless the following safe operating principles of the machine are understood and performed.

- 1) All dangerous work site conditions are avoided.
- 2) Pre-Operation Inspection has been completed.
- 3) The workstation has been inspected.
- 4) The function test has been performed prior to any operation.



NOTICE: The function test must be performed and proper operating procedures understood before the next step.

- 5) The machine is used as described in this manual.

6.1 General Information

- 1) The purpose of the Function Test is to identify potential component failure before operating the machine.
- 2) The operator must test all machine functions as outlined in this section.
- 3) Do not use a damaged or malfunctioning machine. Tag out the control boxes and do not use the machine until repairs have been made.

- 4) Only qualified maintenance technicians are permitted to repair the machine as per the regulations of the manufacturer.
- 5) After repairs or maintenance have been performed, the operator must perform out the Pre-Operation inspection and Functional Test again before operating the machine.

6.2 Function Test

- 1) Carry out the function test on a firm and level surface with no barriers or obstructions.
- 2) Ensure the battery pack is connected.

6.3 Tests from the Ground

Controls

- 1) Pull out the red emergency stop buttons on the platform controller and the ground controller to the ON position.
- 2) Turn the key switch to the ground controller position.
- 3) Observe the LED display on the platform controller and ground controller for the proper reading.

6.4 Test the Emergency Stop

Switch

- 1) Push the emergency stop switch on the



ground control station in to the OFF position.

Result: All Functions should be disabled.

- 2) Pull the emergency stop switch out to the ON position.

6.5 Test the Up/Down Functions



NOTICE: The alarm system will control the buzzer to output the alarms with different frequencies. The lowering alarm will sound 60 times per minute. If the pothole guards fail to deploy and set, the buzzer will sound 180 times per minute. The buzzer will sound 180 times per minute for any overload.

- 1) Position the key switch to the platform controller or the OFF position.
- 2) Press and hold the lift function enabled button, and press the platform up button.
Result: The platform fails to elevate.
- 3) Position the key switch to the ground control position.
- 4) Press and hold the lift function enabled button, and press the platform up button.
Result: The platform will lift.
- 5) Press and hold the lift function enabled button, and press the platform down button.
Result: The platform will lower. When the platform is lowering, the alarm shall sound.

- 6) Press the platform down button again. Result: The platform shall descend to the lowest position. When the platform descends, the alarm shall sound. (If equipped)

6.6 Emergency Lowering Function

Test

- 1) Press and hold the lift function enabled button, and press the platform up button to elevate the platform approximately 60cm.
- 2) Pull out the emergency lowering knob at the right front part of the machine. Result: The platform shall descend. The lowering alarm shall not sound.
- 3) Turn the key switch to the platform controller.

6.7 Platform Controller Test

- 1) Push the platform Emergency Stop Switch in to the OFF position. Result: All functions will not operate.
- 2) Pull the Emergency Stop Switch out to the "ON" position. Result: The LED display will light up.

6.8 Horn Test

- 1) Pull the Emergency Stop Switch out to the "ON" position.
- 2) Push the Enable Switch and activate a function.



- 3) Press the horn button.

Result: The horn will sound.

6.9 Lift Function and Function

Enable Switch Test

- 1) Do not press the enable switch on the control handle.
- 2) Slowly move the control handle forward or backward. Result: All lift functions shall not be operational.
- 3) Press the lift function button.
- 4) Press and hold the enable switch on the control handle.
- 5) Slowly move the control handle forward. Result: The platform shall elevate and the pothole guards shall be deployed.
- 6) Release the platform control handle. Result: The platform will stop elevating.
- 7) Press and hold the enable switch on the control handle. Slowly move the control handle backward. Result: The platform will lower. When the platform lowers, the lowering alarm will sound.

6.10 Steering Test



NOTICE: Face the end of the machine that steers when testing the steering and driving functions.

- 1) Press the drive function button. The drive function indicator will light.
- 2) Press and hold the enable switch on the control handle.
- 3) Press the rocker switch on top of control handle according to the direction indicated by leftward arrows on the control panel. Result: The machine will turn left.
- 4) Press the rocker switch on top of the control handle according to the direction indicated by rightward arrows on the control panel. Result: The machine will turn right.



6.11 Driving and Braking Function

Test

- 1) Press the drive function button.
- 2) Press and hold the enable switch on the control handle.
- 3) Slowly move the control handle in the direction indicated by the blue arrow on the control panel until the machine is moving and return the handle to the center position.
Result: The machine shall move forward and then stop.
- 4) Slowly move the control handle in the direction indicated by the yellow arrow on the control panel until the machine is moving and return the handle to the center position.
Result: The machine shall move backward and then stop.



NOTICE: The brake must be able to hold the machine on any grade it is able to climb.

6.12 Driving Function Test

- 1) Press the lift function button, the indicator lamp will light up. Press and hold the enable switch, move the control handle, and raise/lower the platform to a certain height.
Result: The pothole guardrail will be unfolded/retracted.
- 2) Press the drive function button. The indicator light will light up.
- 3) Press and hold the enable switch on the control handle and slowly move the control handle fully forward.
✓ Result: With the platform raised, do not driver over the maximum allowable value specified in the specifications section.
✗ Result: If the elevated driving speed of the platform exceeds these limits, immediately tag out the controls and stop operation until repairs are made.

6.13 Operation of Tilt Sensor Test



NOTICE: This test is performed with the platform controller from the ground. Do not stand in the platform.

- 1) Completely lower the platform.
- 2) Drive the machine to the slope that just exceeds the maximum allowable tilt angle of the machine.



- 3) Lift the platform to a certain height. Result: The platform will stop moving and the tilt alarm will sound.
 - 4) Slowly move the control handle to operate drive forward and then driver reverse. Result: The drive function will be disabled in either direction.
 - 5) Lower the platform and drive the machine off of the slope.
- 3.5cmx20cm wood block or a similar material and elevate the platform. Result: When the platform is raised to a certain height, the alarm will sound. The drive function will be disabled.
- 5) Lower the platform and remove the blocks.

6.14 Pothole Guard Test



NOTICE: When the platform is elevated, the pothole guards will be automatically deployed. The pothole guards initialize another limit switch to enable the continuous drive/steer operation of machine. If the pothole guards fails to be deployed, the alarm will sound and the machine will stop all drive and steer functions.

- 1) Lift the platform. Result: When the platform is raised to a certain height, the pothole guards shall be deployed.
- 2) Press one side of the pothole guard and then other side. Result: The pothole guard will not move.
- 3) Lower the platform. Result: The pothole guard will be returned to the stowed position.
- 4) Place blocks under the pothole guards





Chapter 7 Operating Instructions



WARNING: Operation is forbidden

unless the following safe operating principles of the machine are understood and performed.

- 1) The dangerous conditions are avoided.
- 2) The pre-operation inspection is always made.
- 3) The workstation is checked.
- 4) The function test is always made before the use.
- 5) The machine is used for its design purposes.

7.1 General Information

- 1) This machine is a mobile elevating work platform, consisting of a work platform on an elevating scissors mechanism. The vibration produced by the running machine causes no hazards to the operators on the work platform. This machine can be used for carrying the workers and their tools to the specified height above the ground and also for reaching the workstation above the machine or equipment.
- 2) Detailed operating instructions for all functions are outlined in this Operation section. It is the operator's responsibility to follow all safety regulations and descriptions in this operation and maintenance manual.
- 3) It is prohibited to use the machine for any

purpose other than carrying the staff, equipment, tool and material to the overhead workstation.

- 4) Only trained and authorized personnel can operate this machine. Each operator shall perform the pre-operation inspection, function test and workstation inspection before running the machine.
- 5) All dealers, owners, users, operators, lessors, lessees, and brokers shall comply with appropriate section(s) of applicable A92 standards.

7.2 Emergency Stop

- 1) Push the emergency stop switch on the ground or platform controller to the OFF position to disable all functions.
- 2) Repair any function that operates when either emergency stop switch is pushed in.



7.3 Emergency Lowering

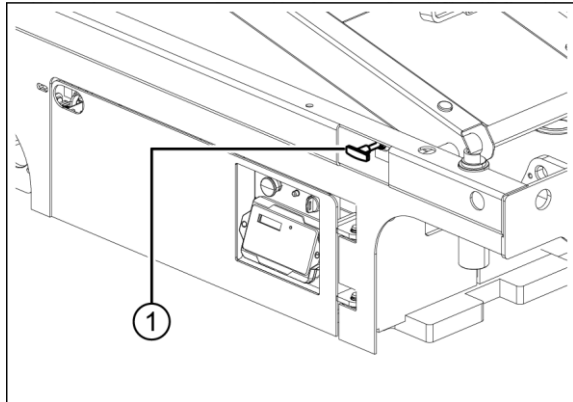

1. Emergency lowering knob

Pull the emergency lowering knob outward to lower the platform.

7.4 Operation from the Ground

Controls

- 1) Turn the key switch to the ground position.
- 2) Pull the emergency stop switch on the ground and the platform to the ON position.
- 3) Ensure the battery tray is connected before running the machine.

7.4.1 Platform Positioning

- 1) Press and hold the lift function enable button.
- 2) Press the platform up/down button.

Note: The driving and turning functions are unavailable from the ground controller.

7.4.2 Entering the Override Mode

When the machine alarms that the platform cannot be lifted or lowered, you shall make the machine enter to the override mode through the

GCU mode to lift or lower the platform.

The override mode is used only in specific situations and does not apply to normal machine operations. Only specially trained personnel can make the machine enter the override mode.

Before the machine enters the override mode, the operator shall fully understand the fault codes or faults that affect machine operations and determine whether it is necessary for the machine to enter the override mode.

⚠ Danger of tipping over!

Before entering the override mode, the machine shall be placed on a piece of firm and level ground; the operator must be specially trained.

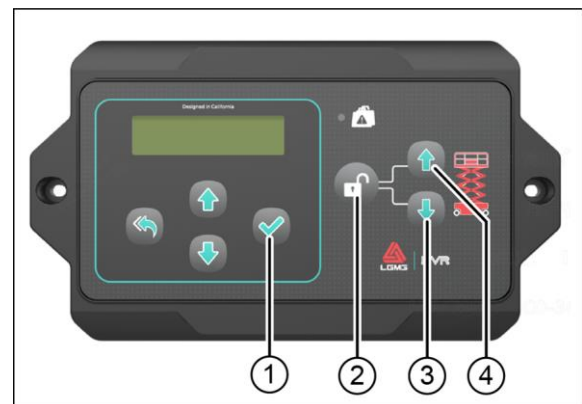

1. Menu enter button
2. Function enable button
3. Platform down button
4. Platform up button

- 1) Pull out the PCU emergency-stop button and the GCU emergency-stop button.
- 2) Long-press the Confirm button and select the



GCU mode using the key switch.

- 3) Enter the "Password" interface and input the password.
 - 4) Enter the system, select "Calibration Function", and confirm the selection. Then, enter "Weighing Function", confirm the selection again, and enter the override mode.
- Note: The machine will alarm after entering the override mode. The screen shows the fault code, fault message, and a "DANGER" prompt in a scrolling way.**
- 5) Long-press the Confirm button and Enable button. Press the Platform up button, if the platform needs to be lifted; press the Platform down button, if the platform needs to be lowered.
 - 6) Click the Return button to exit from the override mode.
 - 7) Exit from the system interface after the control system is restarted using the key switch.

7.5 Operation from the Platform

Controls

- 1) Turn the key switch to the platform control position.
- 2) Pull the emergency stop switch out on both ground controls and the platform controls to

the ON position.

- 3) Ensure the battery tray is connected before running the machine

7.5.1 Platform Positioning

- 1) Press the lift function button.
- 2) Press and hold the enable switch on the control handle.
- 3) The platform will raise when the control lever is moved to the forward, or lower when the control lever is moved to the backward.

7.5.2 Steering

- 1) Press the drive function button.
- 2) Press and hold the enable switch on the control handle.
- 3) Turn the wheels in the desired direction using the rocker switch on the top of control handle.

7.5.3 Drive

- 1) Press the drive function button.
- 2) Press and hold the enable switch on the control handle.
- 3) To increase speed: Slowly move the control handle away from the centered position. To decrease speed: Slowly return the control handle to the center position. To stop: Fully return the handle to the center position or release the enable switch.
- 4) Coordinate machine drive direction with the



direction arrows on the platform controller and the platform.

- 5) When the platform is elevated, the drive speed of the machine is reduced.
- 6) The status of the battery pack will affect machine performance.
- 7) When the battery level indicator lamp flashes, driving speed and functional speed of machine will be reduced.









7.5.4 Drive Speed Option

The drive controller can be operated at two different drive speeds. When the drive speed selector switch indicator lights up, slow driving speed mode is enabled. When the driving speed selector switch lamp goes out, the high speed drive mode is enabled. Press the driving speed selector switch to select the desired driving speed.

7.6 Using Platform Controller to Drive the Machine on the Ground

- 1) Keep a safe distance between the operator, machine, and any stationary object.
- 2) Be cautious and aware of the driving direction of machine when using the controller from the ground.
- 3) Identify the battery level with the LED display.

Battery Level as Shown on LED Display

Platform Display	Battery Percentage (%)	Description
	90-100	The battery capacity is full
	70	Percentage of remaining battery capacity
	50	Percentage of remaining battery capacity
	30	Percentage of remaining battery capacity
	20	The battery must be charged
	10	The battery capacity is very low





NOTICE: When the battery capacity is very low ($\leq 10\%$), the machine will change to low speed mode automatically.



7.7 Driving on a Slope

Determine the slope and side slope ratings for the machine and determine the slope grade.

<p>Maximum slope rating, stowed position:</p> 	<p>25%(14°)</p>
<p>Maximum side slope rating, stowed position:</p> 	<p>25%(14°)</p>

Note: Slope rating is subject to ground conditions with one person in the platform and adequate traction. Additional platform weight may reduce slope rating.

Measure the slope by using a digital inclinometer or as per the following steps.

- ✓ Required tools: Carpenters rule, straight wood block (with length of at least 1m), tape measure and other tools.
- ✓ Place the wood block on the slope, place the carpenters rule on the upper limb of the wood block at the end of down-slope, and lift the end of the wood block until it is horizontal.
- ✓ Keep the wood block in the horizontal state, and measure vertical height from the bottom of the wood block to the ground.
- ✓ Height is divided by the length of wood block

(stroke), i.e.,

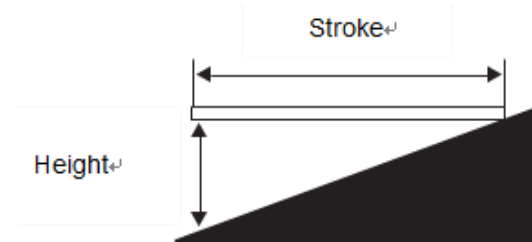

Stroke=3.6m

lifting height=0.3m

$$0.3 \div 3.6 = 0.083 \times 100\% = 8.3\%$$

If the slope exceeds the maximum uphill, downhill or side slope rating, the vehicle must be winched or transported up or down the slope.

7.8 Using the Safety Prop

- 1) Raise the platform to a certain height above the ground.
- 2) Lift the safety prop, move it to the center of the scissor cross tube and rotate it upward until it is vertical.
- 3) Lower the platform height until the safety prop completely contacts the shaft tube. Keep the platform away from the movable parts during the lowering process.



DANGER: Do not carry any load in the platform when the safety prop is being used.

No long time (8 hours) to use safety prop in empty state.



7.9 How to Stow the Guardrail

The platform guardrail system consists of a folding guardrail on an extended platform and a folding guardrail on the main platform.

- 1) Fully lower the platform and lock it into the extended platform.
- 2) Remove the platform controller.
- 3) Remove the M-shaped fixed seat between the guardrails of the main platform and the extended platform from the inside of the platform and place it in the platform.
- 4) Remove the retaining pins at the front of the extended platform from the inside of the main platform.
- 5) Fold the front guardrail of the extended platform inward. Do not place your hands in places where there may be a pinch point. At the same time, prevent the left and right guardrails of the extended platform from tilting over.
- 6) Install the retaining pins which were removed back to the guardrail on each side.
- 7) Fold the left guardrail of the extending platform inward. Do not place your hands in places where there may be a pinch point. At the same time, prevent the right guardrails of the extended platform from tilting over.
- 8) Fold the right guardrail of the extending platform inward. Do not place your hands in places where there may be a pinch point.
- 9) Remove the two retaining pins on the upper part of the door.
- 10) Fold the door guardrail from the ladder or the ground inward. Do not place your hands in places where there may be a pinch point. At the same time, prevent the guardrails of the extended platform from tilting over.
- 11) Fold the left guardrail of main platform from the ladder or the ground inward. Do not place your hands in places where there may be a pinch point. At the same time, prevent the right guardrails of the main platform from tilting over.
- 12) Fold the right guardrail of main platform from the ladder or the ground inward. Do not place your hands in places where there may be a pinch point.
- 13) Install the retaining pins which were removed back to the guardrail on each side.

7.10 How to Erect the Guardrail

To erect the guardrails, reverse the sequence outlined in How to Stow the Guardrail.



7.11 Extending and Retracting the

Extending Platform Deck

- 1) Step on the positioning pedal on the extending platform.
- 2) Push the guardrail of the extending platform to extend the platform to the desired position.



NOTICE: Do not stand on the extending platform deck while extending it.

7.12 Power Supply Switch

DC power switch (If equipped)

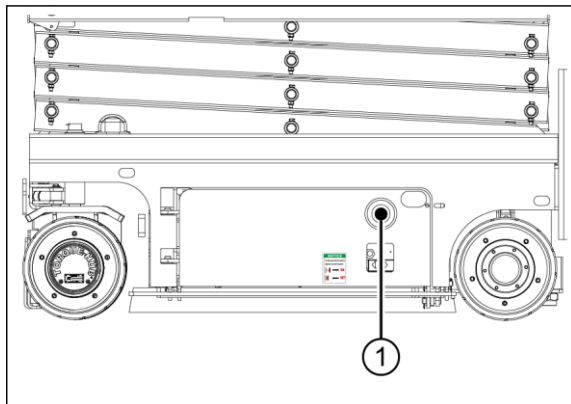

1. DC power switch

Press the DC power switch, power supply of the whole machine will be disconnected.

Pull out the DC power switch and power supply of the whole machine will be connected.



7.13 Error Codes



NOTICE: When an error code is present, the code will flash once per second on the screens of the ECU and PCU.

Error Codes

Display	Description	Response
01	System initialization error	Stop all actions
02	System communication error	Stop all actions
03	Model error	Stop all actions
05	ECU and BMS communication failure	Lifting and travelling are prohibited.
09	Invalid pedal alarm	Stop lifting and running
10	The alarm switch is on when height limit rod is being touched	Stop lifting and running
11	Upper&Lower limit abnormality	Display alarm only
12	Chassis lifting or lowering button opening error during start	Stop all chassis controls
14	Motor controller 1 communication failure	Stop lifting and running
15	Motor controller 2 communication failure	Stop lifting and running
16	BMS fault	Stop lifting and running
18	Pothole protection error	Stop lifting and running
23	Traveling function is limited when lifting	Stop running
27	Down proportional valve fault	Stop lifting and running
31	Pressure sensor error	Stop lifting and running
32	Angle sensor error	Stop lifting and running
33	No calibration of light load	Stop lifting
34	Down after overload	Display alarm only
35	Load calibration error	Display alarm only
36	Low battery alarm	Speed reduced to low speed
38	Load calibration error	Stop lifting
40	GPS communication failure	Display alarm only
41	GPS level 1 lockout	Stop lifting
42	Platform left turn button pressing error during start	Display alarm only
43	Platform right turn button pressing error during start	Display alarm only
44	ZAPI 1 fault (AC pump motor parameter fault)	Display alarm only
45	ZAPI 2 fault (AC pump motor hardware fault)	Display alarm only
46	Platform handle enable switch button pressing error during start	Stop platform control
47	"The platform handle is not in the middle position" error during start	Display alarm only
49	AC pump motor: Motor fault detected	Display alarm only
50	AC pump motor connector fault	Display alarm only
51	Wireless collision avoidance alarm	Stop lifting



Operation Manual of Scissors Mobile Elevating Work Platform

52	Forward coil error	Stop lifting and running
53	Backward coil error	Stop lifting and running
54	Lifting error of lifting coil	Stop lifting and running
55	Lifting error of lowering coil	Stop lifting and running
56	Right turn coil error	Stop lifting and running
57	Left turn coil error	Stop lifting and running
58	Brake coil error	Stop lifting and running
60	Motor controller fault	Stop lifting and running
61	Motor controller current sensor fault	Display alarm only
62	Motor controller damaged hardware fault	Display alarm only
63	Motor controller output fault	Display alarm only
64	Motor controller SRO fault	Display alarm only
67	Motor controller HPD fault	Display alarm only
68	Low voltage fault	Lifting and high speed running are prohibited
69	Motor controller	Stop lifting and running
70	Motor controller	Stop lifting and running
71	Motor controller contactor fault	Stop lifting and running
73	Motor controller overheated	Display alarm only
74	Motor controller fault	Display alarm only
75	Motor controller pump motor fault	Stop lifting and running
76	Motor controller left drive motor fault	Stop lifting and running
77	Motor controller right drive motor fault	Stop lifting and running
78	Motor controller pump motor short-circuit fault	Stop lifting and running
79	Left drive motor short-circuit fault	Stop lifting and running
80	Alarm of exceeding 80% load	Alarm only
81	Right drive motor short-circuit fault	Stop lifting and running
82	Left brake coil fault	Stop lifting and running
83	Right brake coil fault	Stop lifting and running
84	Motor POST Short Fault	Stop lifting and running
89	Motor excitation open-circuit fault	Stop lifting and running
90	Alarm of exceeding 90% load	Alarm only
91	Motor excitation short-circuit error	Stop lifting and running
92	Motor excitation short-circuit error	Stop lifting and running
93	AC pump brake fault	Display alarm only
94	AC pump drive temperature fault	Display alarm only
95	AC pump motor temperature fault	Display alarm only
96	AC pump abnormal voltage/ electric quantity	Display alarm only
97	AC pump CANBUS communication fault	Display alarm only
98	AC pump speed sensor fault	Display alarm only



Operation Manual of Scissors Mobile Elevating Work Platform

99	Alarm of exceeding 99% load	Alarm only
100-114	Three-phase AC motor drive node 8 fault (100-144)	Display alarm only
115-128	Three-phase AC motor drive node 9 fault (115-128)	Display alarm only
129-142	Three-phase AC motor drive node A fault (129-142)	Display alarm only
OL	Platform overload alarm	Stop all actions
LL	"The machine tilts over the safety limit" error	Stop lifting and running

Troubleshooting Guide

Display	Description
01	Restart device or replace ECU
02	System communication error: Check connection between the communication line and other cables. If fault still exists, please replace the PCU or the ECU
03	Invalid option setting error: Set proper options for the machine
05	Check if CAN bus are contacted well or have lithium battery replaced
09	Release the pedal switch, if it is invalid, check the connection status of pedal harness (check for short-circuit)
10	Down alarm override
11	Reset upper limit switch or outdoor limit switch
12	Check if the chassis lifting or descending button is pressed when powered on, or replace ECU
14	Check if CAN bus are contacted well or have electric drive type modified
15	Check if CAN bus are contacted well or have electric drive type modified
16	Check if CAN bus are contacted well or have lithium battery replaced
18	Pothole protection error: Check whether the pothole protection is activated, and check the pothole protection limit switch. Check the wiring of the switch, lower limit switch and wiring.
23	Down alarm override
27	Check or replace the down proportional valve
31	Pressure sensor error: Check the sensor wiring and the sensor. Check to confirm that the correct machine option with overload detection is selected
32	Angle sensor error: Check the sensor wiring and the sensor. Check to confirm that the correct machine option with overload detection is selected
33	Calibrate light load, or shut off double load function
34	This fault is only apply to warn the operator
35	Recalibrate no load and full load
36	When the battery power is low, charge it in time; If the battery power is normal, check the wiring or replace the ECU,
38	Recalibration
40	Check if CAN bus are contacted well or have GPS device replaced
41	Unlock or contact GPS device
42	Platform left turn button pressing error during start: Ensure that buttons on the handle are not pressed. If not, consider replacing the handle or the PCU



Operation Manual of Scissors Mobile Elevating Work Platform

Display	Description
43	Platform right turn button pressing error during start: Ensure that buttons on the handle are not pressed. If not, consider replacing the handle or the PCU
44	Replace the motor driver or contact the motor manufacturer
45	Replace the motor driver or contact the motor manufacturer
46	Platform handle enable switch button pressing error during start: Ensure that the enable switch on the handle is not pressed. If not, consider replacing the handle or the PCU
47	“The platform handle is not in the middle position” error during start: Confirm that the handle is in the middle position, and check the middle position parameter setting. If normal, consider replacing the handle or the PCU
49	Replace the motor driver or contact the manufacturer
50	Replace the motor driver or contact the manufacturer
51	Down alarm override
52	Forward coil error: Check the connection of the coil and confirm that it is normal. If normal, check the coil for short circuit or open circuit
53	Backward coil error: Check the connection of the coil and confirm that it is normal. If normal, check the coil for short circuit or open circuit
54	Lifting error of lifting coil: Check the connection of the coil and confirm that it is normal. If normal, check the coil for short circuit or open circuit
55	Lifting error of lowering coil: Check the connection of the coil and confirm that it is normal. If normal, check the coil for short circuit or open circuit
56	Right turn coil error: Check the connection of the coil and confirm that it is normal. If normal, check the coil for short circuit or open circuit.
57	Left turn coil error: Check the connection of the coil and confirm that it is normal. If normal, check the coil for short circuit or open circuit.
58	Brake coil error: Check the connection of the coil and confirm that it is normal. If normal, check the coil for short circuit or open circuit.
60	Replace the motor driver or contact the manufacturer
61	Replace the motor driver or contact the manufacturer
62	Replace the motor driver or contact the manufacturer
63	Replace the motor driver or contact the manufacturer
64	Replace the motor driver or contact the manufacturer
67	Replace the motor driver or contact the manufacturer
68	Charge in time; when battery is working well , check the cable or replace the ECU
69	Replace the motor driver or contact the manufacturer
70	Replace the motor driver or contact the manufacturer
71	Replace the motor driver or contact the manufacturer
73	Replace the motor driver or contact the manufacturer
74	Replace the motor driver or contact the manufacturer
75	Replace the motor driver or contact the manufacturer



Operation Manual of Scissors Mobile Elevating Work Platform

Display	Description
76	Replace the motor driver or contact the manufacturer
77	Replace the motor driver or contact the manufacturer
78	Replace the motor driver or contact the manufacturer
79	Replace the motor driver or contact the manufacturer
80	Alarm of exceeding 80% load: As the platform is close to the load limit, it is not recommended to increase the load
81	Replace the motor driver or contact the manufacturer
82	Check the connection of the coil and confirm that it is normal. If normal, check the coil for short circuit or open circuit.
83	Check the connection of the coil and confirm that it is normal. If normal, check the coil for short circuit or open circuit.
84	Replace the motor driver or contact the manufacturer
89	Replace the motor driver or contact the manufacturer
90	Alarm of exceeding 90% load: As the platform is close to the load limit, it is not recommended to increase the load
91	Replace the motor driver or contact the manufacturer
92	Replace the motor driver or contact the manufacturer
93	Replace the motor driver or contact the manufacturer
94	Replace the motor driver or contact the manufacturer
95	Replace the motor driver or contact the manufacturer
96	Replace the motor driver or contact the manufacturer
97	Replace the motor driver or contact the manufacturer
98	Replace the motor driver or contact the manufacturer
99	Alarm of exceeding 99% load: As the platform has reached the load limit, do not to increase the load
100-114	Replace the motor driver or contact the manufacturer
115-128	Replace the motor driver or contact the manufacturer
129-142	Replace the motor driver or contact the manufacturer
OL	Platform overload alarm: Remove excessive loads immediately
LL	If the machine is tilted, try to restore it to horizontal level, and if not tilted, it needs to check the level sensor wiring and the sensor itself and recalibrate.





Chapter 8 Transport and Lifting Instructions

 **WARNING: Obey these instructions.**

- When lifting the machine with a crane, ensure the crane has the proper capacity and rigging to handle the weight of the machine.
- Only qualified personnel are allowed to load and unload the machine onto a truck for transport.
- The hauling vehicle must be parked on firm, level ground.
- When loading the machine, be sure to chock the wheels of the hauling vehicle to ensure it won't move.
- Ensure vehicle capacity, load surface, and tie down equipment is adequate for bearing the weight of the machine. Refer to the nameplate on the machine for gross weight.
- Be sure to load the machine on a flat, level surface and chock the wheels before releasing the brake.
- Do not drive the machine when traveling up and down a slope or when driving on a slope exceeding the rated gradeability for the machine. For driving on a slope, refer to Chapter Operating Instructions. If the loading

ramp of the hauling vehicle exceeds the maximum rated travel grade of the machine, load and unload the machine with a winch as per the instruction for brake releasing operation.

8.1 Releasing the Brake

 **COLLISION HAZARD: Failure to secure machine before releasing brakes will result in death or serious injury.**

- 1) Make sure machine is on a firm, level surface or secured.
- 2) Chock wheels.
- 3) Release brakes.

Brake Release Operation (For electric drive models)

 **NOTICE: Before release the brake, the main power supply should be connected, and the emergency stop switch on the chassis and platform must be cut off.**

- 1) Chock wheels to prevent machine from rolling.
- 2) Be sure winch line is properly secured to drive chassis tie points and path is clear of all obstructions.



- 3) Turn and hold the key switch to release the brake.

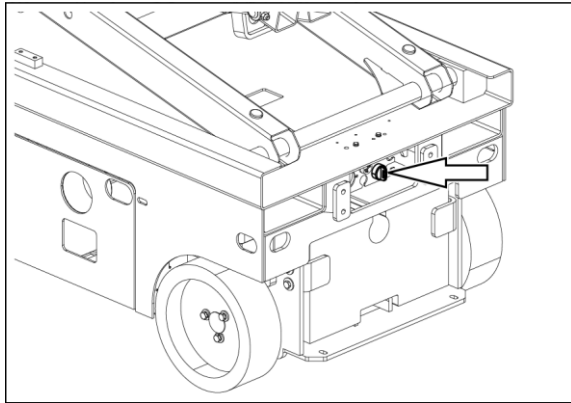

After brake release operation:

- 1) Chock wheels to prevent machine from rolling.
- 2) Turn the key switch to the off position to engage the brake.
- 3) If system voltage is lower than 16.8v, operate the drive motor according to the following procedure.

- a) Unscrew the drive motor end cover;



- b) Screw the bolt into the screw holes in the brake disc, see Figure2 ;



- c) Turn the bolt clockwise. When the brake clearance is greater than 0.003in (0.08 mm), the brake is released.



- d) Repeat the above procedure on opposite drive motor. With both drive motor brake released the machine can be moved manually.
- e) After moving the machine, reinstall both drive motors to the original conditions.



Brake Release Operation (For hydraulic drive models)

- 1) Chock the wheels to prevent the machine from moving.
- 2) Make sure all lifting devices are properly fastened at the designated tie down/lifting points on the chassis, and there are no obstacles in the way.
- 3) Push the black brake Valve rod to open the brake valve.

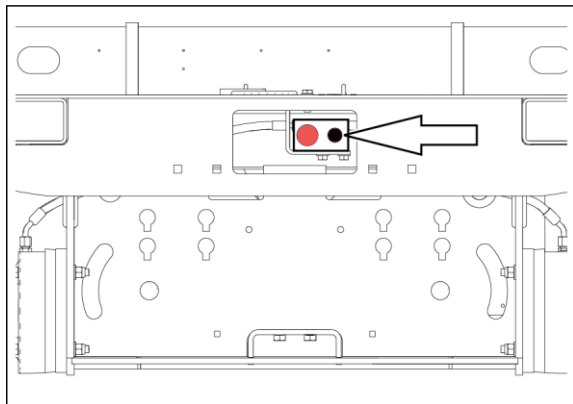

- 4) Repeatedly press the pump rod to release the disc brake.

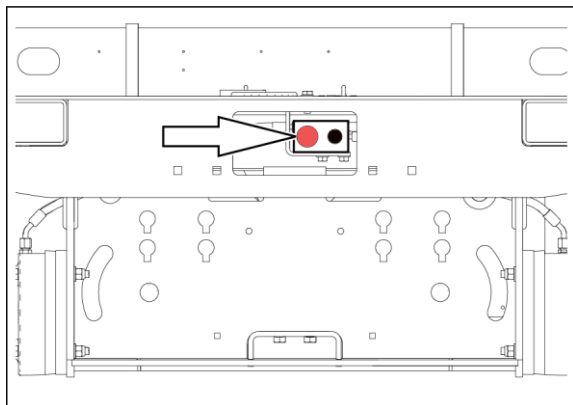

- 5) Extract the valve rod to reengage the machine brake.

8.2 Transport Safety

- 1) Chock the machine wheels when preparing for transport.
- 2) Retract and secure the extending platform.
- 3) Switch the key switch to the OFF position and take out the key before transporting the machine. Disconnect and remove the platform control box. Store in a safe location prior to transporting the machine.
- 4) Ensure the front and rear wheels are securely chocked and the machine is inspected to ensure there are no loose or unsecured parts.
- 5) Secure the machine on the transport surface using the tie down areas on the chassis.



- 6) Use at least four chains or tie straps.

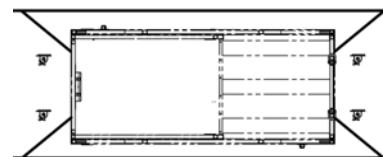

- 7) Be sure to use chains or tie straps of sufficient load capacity.



- 8) Secure the folded guard rail (if any) with a tie strap before transport



WARNING: Obey the following instructions.

- Only personnel qualified in loading and transporting heavy equipment can rig lifting equipment and lift the machine.
- Only personnel qualified in forklift operation qualification are permitted to load and unload the machine with a forklift.
- Ensure that the lifting capacity, loading surface, loading straps, or rope of the crane is sufficient to bear the machine weight. For serial number, please refer to the nameplate.

8.3 Loading the Machine with a Forklift

- 1) Be sure to secure the extending platform, the controller and the chassis tray. Remove all movable components from the machine.
- 2) Completely lower the platform. Keep the platform folded in each transport process.
- 3) Use the forklift pockets on both sides of the ladder.

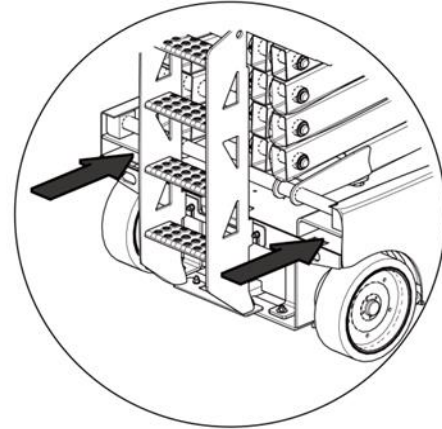

- 4) Place the forks of the forklift into the forklift pockets.
- 5) Drive the forklift forward to completely insert the fork into the pockets.
- 6) Lift the machine by 40cm and slightly tilt the fork backward to keep the machine stable.
- 7) Keep the machine level when lowering the fork.



NOTICE: Component damage may result from the machine being lifted from its' side.



8.4 Lifting Precautions

- 1) Completely lower the platform. Be sure to secure the extending platform, the controller and the chassis tray. Remove all movable components from the machine.



NOTICE: Use the center of gravity

shown on the lifting decal on the machine.

- 2) The spreader can only be attached to the specified lifting point on the machine shown.
- 3) There are two lifting holes in the front panel of the machine, and there are two lifting holes in the rear end board to use for lifting the machine.
- 4) Adjust the lock tool in such a way that the machine is not damaged and the machine is kept horizontal.

8.5 Parking and Storage

Follow the parking and storage instructions below:

- 1) Drive the machine to a well-protected and well-ventilated area.
- 2) Be sure to completely lower the platform.
- 3) Push the emergency stop switch in to the OFF position.
- 4) If necessary, cover the control panel and the warning signs to protect them against the environment.
- 5) If the machine is parked for a long period, cover the wheels on both sides with a blocking board.
- 6) Turn the power supply selector switch to the OFF position and pull out the key to avoid starting and unauthorized use of equipment.
- 7) If equipped with the optional anti-vandalism package, the working station and ground control box can be covered and locked to prevent vandalism.





Chapter 9 Decals and Warning Labels

Decal Diagram

S1932E Decal Diagram

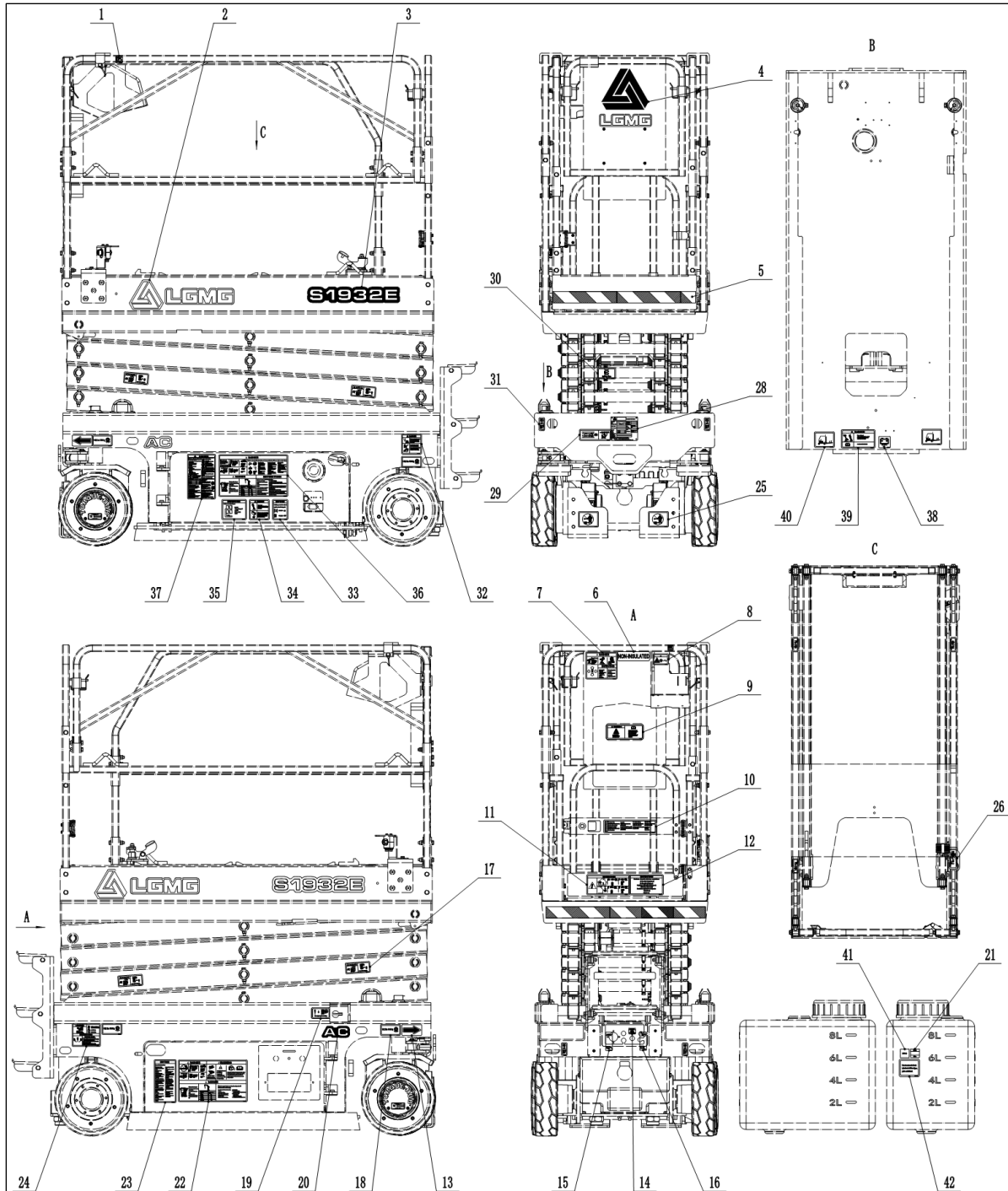



Operation Manual of Scissors Mobile Elevating Work Platform

Name	Decal	Name	Decal
1. Decal-Platform controls location		22. Decal-Hydraulic tank side	
2. Decal-LGMG logo		23. Decal-Notice	
3. Decal-Model S1932E		24. Decal-Brake release safety warning	
4. Decal-LGMG logo		25. Decal-Do not spray water	
5. Decal-Warning strip		26. Decal-Lanyard attachment point	
6. Decal-Non-insulated		28. Machine nameplate (Mexico)	
7. Decal-Front guard rail decal		29. Decal-Transport tie-down	
8. Decal-Drive at a low speed on slope		30. Decal-Safety arm	
9. Decal-Read the manual		31. Decal-Lifting	





Operation Manual of Scissors Mobile Elevating Work Platform

10. Decal-Operating instructions		32. Decal-Electrocution/fire hazard	
11. Decal-Platform safety warning		33. Decal-Power on/off	
12. Decal-Maximum manual force		34. Decal-Battery as counterweight	
13. Decal-Forward direction		35. Decal-Battery connection instructions	
14. Decal-Brake release		36. Decal-Battery side decal	
15. Decal-Charging harness		37. Decal-Safety rules	
16. Decal-Power cable to platform		38. Decal-Battery charging	
17. Decal-Away from machine warning		39. Decal-Tip-over hazard	
18. Decal-Wheel load		40. Decal-Forklift pocket	
19. Decal-Emergency lowering		41. Decal-HV32 hydraulic oil	

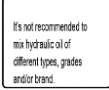

Operation Manual of Scissors Mobile Elevating Work Platform

20. Decal- Alternating current		42. Decal-Do not mix hydraulic oils	
21. Decal-Oil level			



S1932 II Decal Diagram

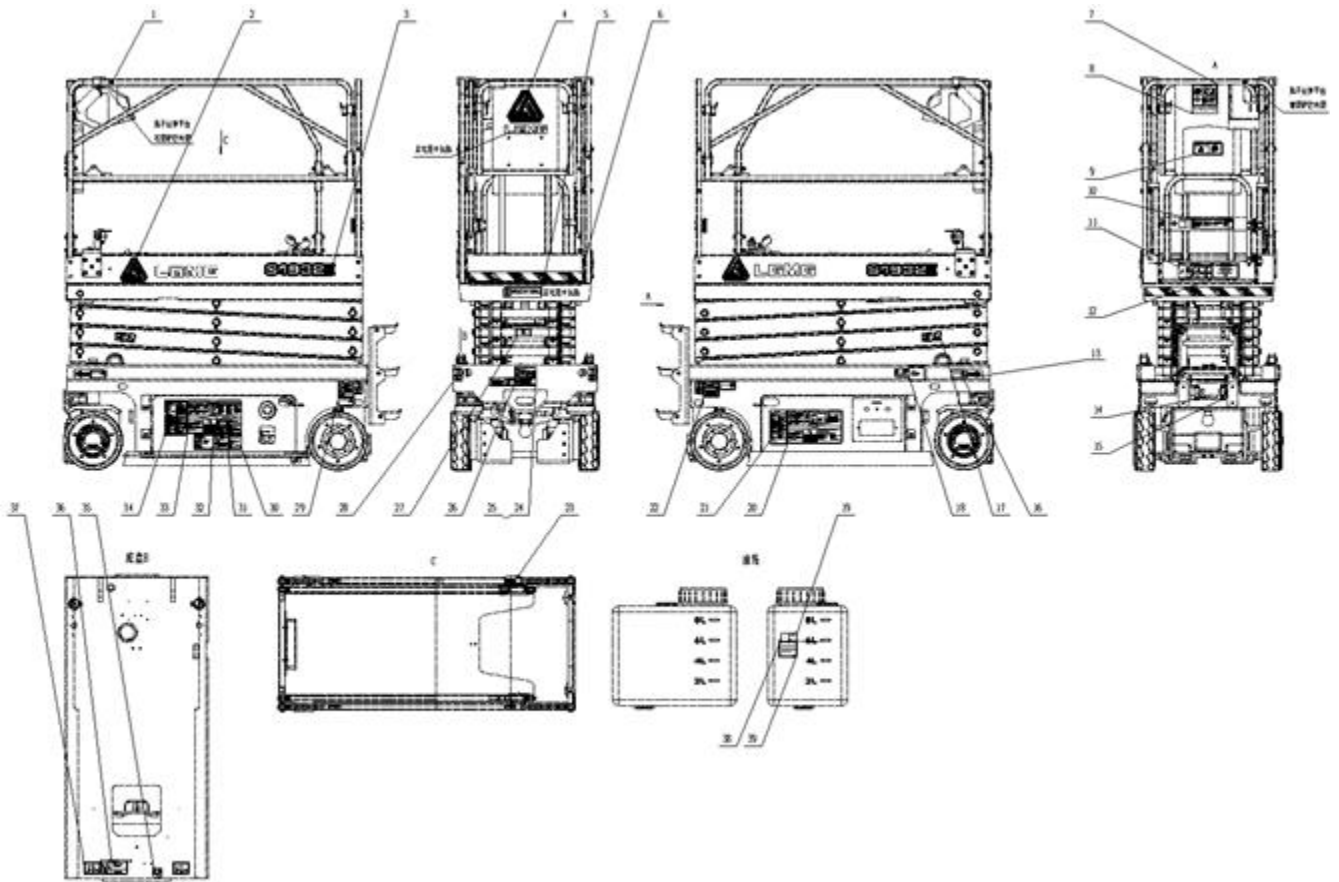



S1932 II Decal List

Item	Description	Item	Description
1	Decal-Platform controls location	24	Decal-Machine nameplate
2	Decal-Company Logo	25	RIVET
3	Decal-Model	26	Decal-Transport
4	Decal-Company Logo	27	Decal-Fork safety arm
5	Decal-Country of origin decal	28	Decal-Lifting
6	Decal-Warning line	29	Decal-ELEC shock fire warning
7	Decal-Front guardrail decal	30	Decal-Turn off power
8	Decal-Non-insulated	31	Decal-Battery as counterweight warning
9	Decal-Read the manual	32	Decal-Battery connection decal
10	Decal-Warning, Platform safety	33	Decal-Battery side decal
11	Decal-Platform safety warning	34	Decal-Safety rules
12	Decal-Maximum manual force	35	Decal-Battery charging
13	Decal-Travel direction	36	Decal-Risk of tipping
14	Decal-Charging harness	37	Decal-Forklift pocket
15	Decal-Power cable to platform	38	DECAL-HV32 HYD OIL DECAL
16	Decal-Wheel load	39	Decal-No mixing of hyd oil
17	Decal-Away from the machine	40	
18	Decal-Emergency lowering	41	
19	Decal-Oil level	42	
20	Decal-Oil tank side	43	
21	Decal-Precautions	44	
22	Decal-Brake release safety warning	45	
23	Decal-Lanyard anchorage point	46	



Operation Manual of Scissors Mobile Elevating Work Platform

S1932 II Decals

1	2	3	4	5	6
7	8	9	10	11	12
13	14	15	16	17	18
19	20	21	22	23	24
25	26	27	28	29	30
31	32	33	34	35	36
37	38	39			



S1932E II Decal Diagram

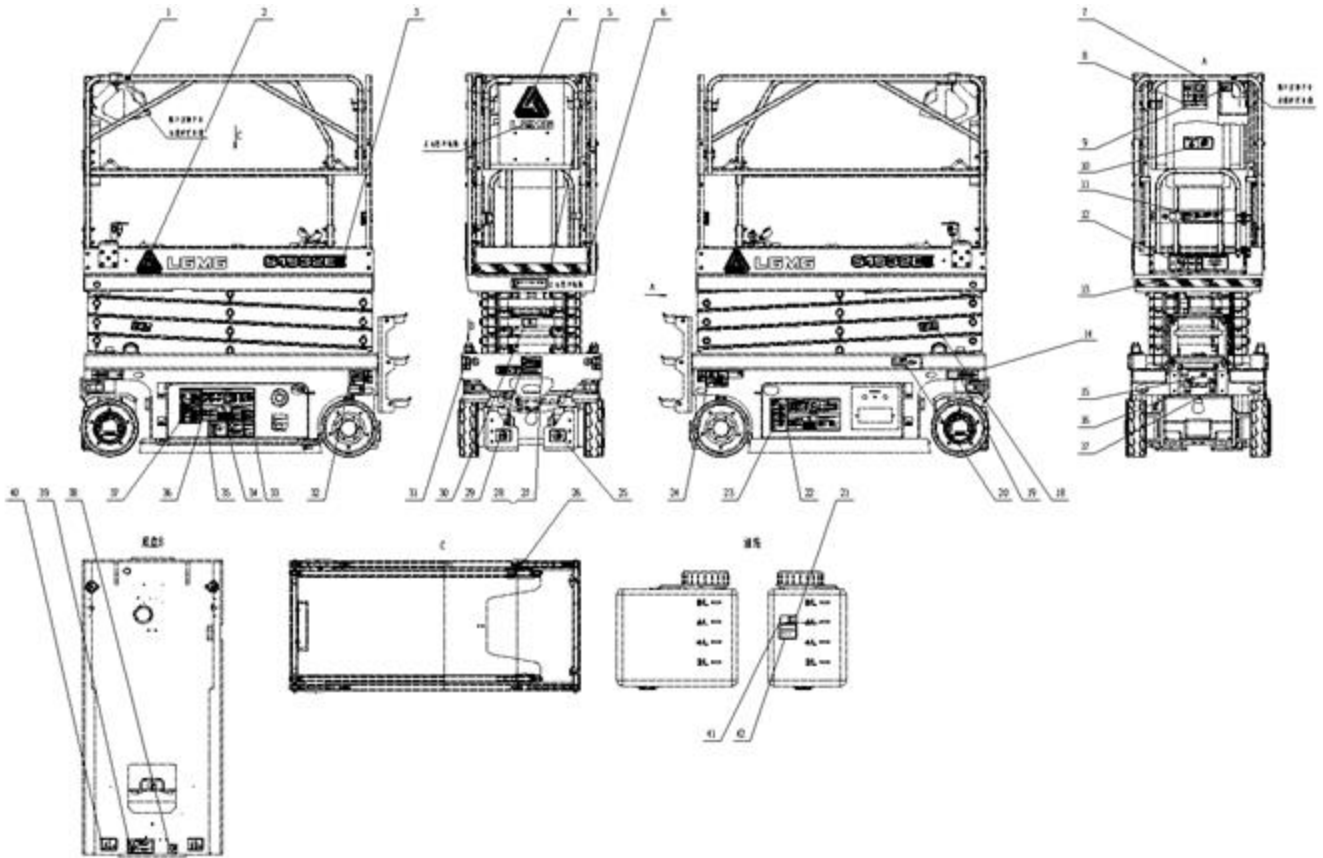



























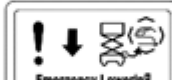





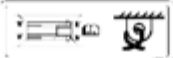
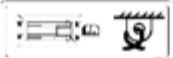

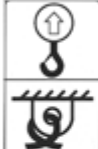
S1932E II Decal List

Item	Description	Item	Description
1	Decal-Platform controls location	24	Decal-Brake release safety warning
2	Decal-Company Logo	25	Decal-No spray
3	Decal-Model	26	Decal-Lanyard anchorage point
4	Decal-Company Logo	27	Decal-Machine nameplate
5	Decal-Country of origin decal	28	RIVET
6	Decal-Warning line	29	Decal-Transport
7	Decal-Front guardrail decal	30	Decal-Fork safety arm
8	Decal-Non-insulated	31	Decal-Lifting
9	Decal-Slow speed	32	Decal-ELEC shock fire warning
10	Decal-Read the manual	33	Decal-Turn off power
11	Decal-Warning, Platform safety	34	Decal-Battery as counterweight warning
12	Decal-Platform safety warning	35	Decal-Battery connection decal
13	Decal-Maximum manual force	36	Decal-Battery side decal
14	Decal-Travel direction	37	Decal-Safety rules
15	Decal-Brake release instructions	38	Decal-Battery charging
16	Decal-Charging harness	39	Decal-Risk of tipping
17	Decal-Power cable to platform	40	Decal-Forklift pocket
18	Decal-Away from the machine	41	DECAL-HV32 HYD OIL DECAL
19	Decal-Wheel load	42	Decal-No mixing of hyd oil
20	Decal-Emergency lowering	43	
21	Decal-Oil level	44	
22	Decal-Oil tank side	45	
23	Decal-Precautions	46	

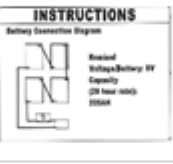

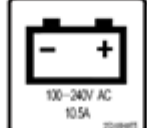
S1932E II Decals

1  Platform Controls Location	2  LGMG	3 S1932E II	4  LGMG	5  MADE IN CHINA	6 
7  DANGER INSTRUCTIONS	8 NON-INSULATED	9 	10 	11 	12 
13  INSTRUCTION 8 Maximum allowed lift force on platform 40 lbs (20 kg) (Class 1) 30 lbs (15 kg) (Class 2) Maximum allowed wind speed 12.1 miles (20 mph) Maximum number of occupants 1 (Class 1) 2 (Class 2)	14 	15 DANGER BRAKE RELEASE See manual on disc on side of base	16 	17 	18  DANGER Falling object Do not stand in the path of the platform when it is moving.
19  1322lbs/600kg	20  Emergency Lowering	21 Max Min	22 	23  NOTICE	24  DANGER INSTRUCTIONS
25 	26 	27 	28 	29 	30  Safety Arm
31 	32  DANGER Electrical Power Hazard Do not touch electrical parts when the power is on. Control panel is connected to the power source. Take care not to touch electrical parts when the power is on.	33  NOTICE Shut off the power before the machine is repaired or serviced. ON OFF	34  DANGER Falling object Do not stand in the path of the platform when it is moving. Do not stand in the path of the platform when it is moving.	35  INSTRUCTIONS Battery Connection Diagram Recharge Battery Capacity: 200 hour (about 20000)	36 
37 	38  100-240V AC 10 SA	39  DANGER Sharp edges Do not touch sharp edges when the power is on.	40 	41 HV32	42 It's not recommended to mix hydraulic oil of different types, grades and/or brand.



Operation Manual of Scissors Mobile Elevating Work Platform

S2632E Decals

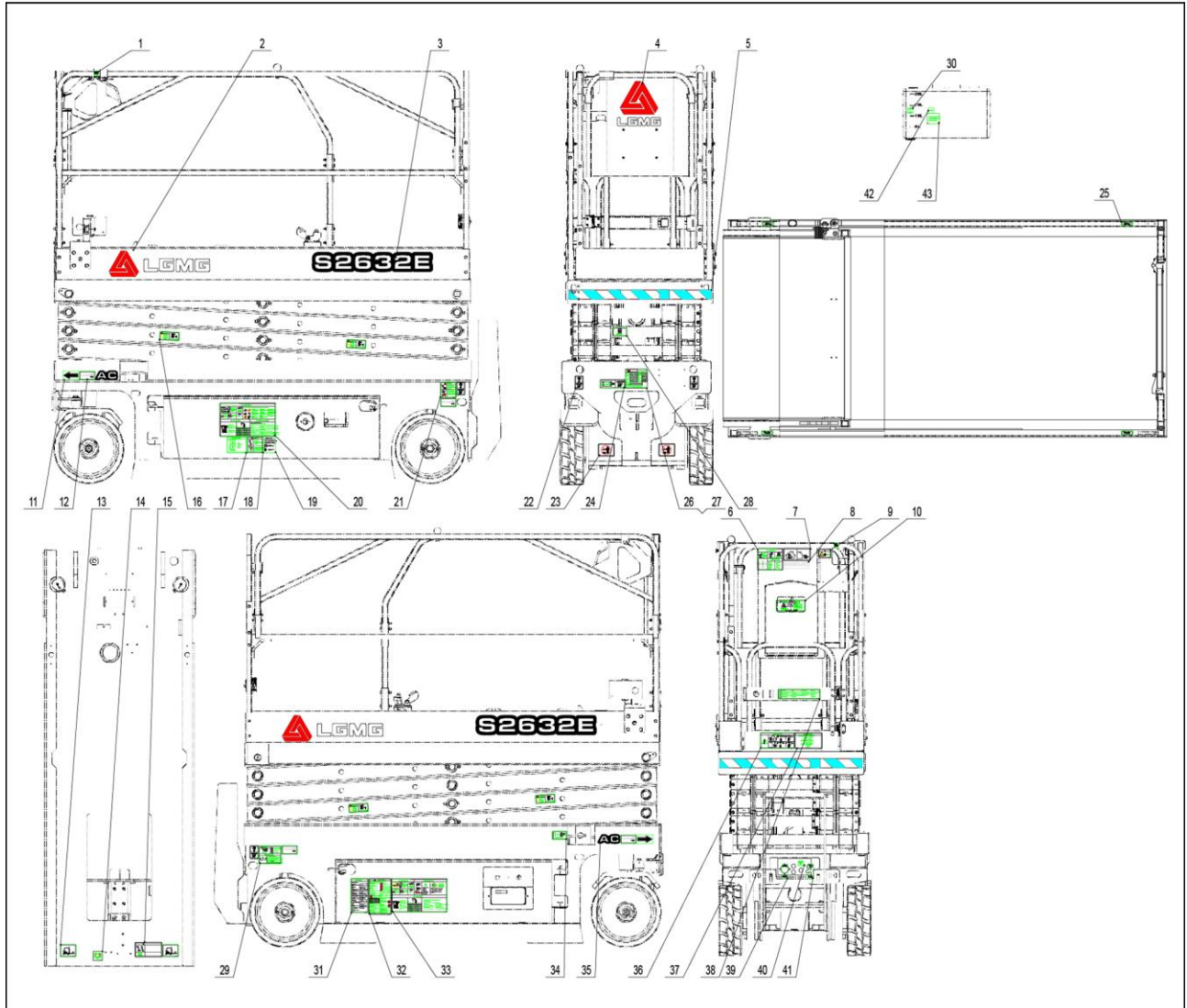













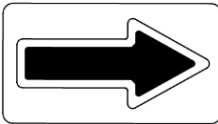

Operation Manual of Scissors Mobile Elevating Work Platform

Name	Decal	Name	Decal
1. Decal-Suspension position		22. Decal-Lifting decal	
2. Decal-LOGO-High 130		23. Decal-No water spraying decal	
3. Decal-Model S2632E		24. Decal-Transport fastening part	
4. Decal-LOGO-High 240		25. Decal-Lanyard anchorage point	
5. Warning wire		26. Complete machine nameplate (Mexico)	
6. Decal-FR column decal		28. Decal-Fork safety arm decal	
7. Decal-Toggle alert		29. Decal-Brake release safety warning	

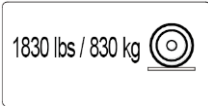
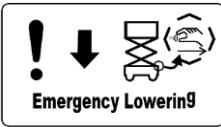

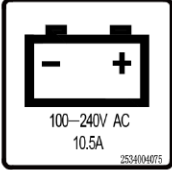
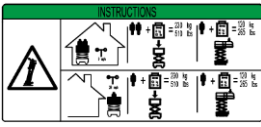

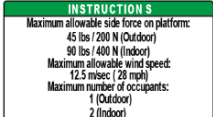



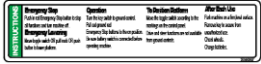
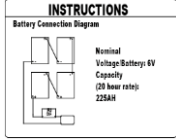

Operation Manual of Scissors Mobile Elevating Work Platform

8. Decal-Non-insulating decal		30. Decal-Oil level decal	
9. Decal-Slope low speed warning		31. Decal-Precautions	
10. Decal-Manual		32. Decal-Safety rules	
11. Decal-Travel direction		33. Decal-Fuel tank side decal	
12. Decal-Wheel load decal		34. Decal-Emergency descent decal	
13. Decal-Telehandler		35. Decal-Alternating current decal	
14. Decal-Battery charging decal (10.5A)		36. Decal-Platform security warning	
15. Decal-Risk of tipping		37. Decal-Max. manual force decal	

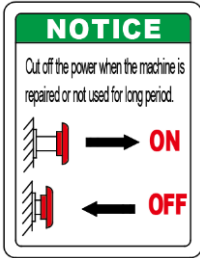

Operation Manual of Scissors Mobile Elevating Work Platform

<p>16. Decal-Stay away from machine warning</p>		<p>38. Decal-Operating instructions</p>	
<p>17. Decal-Battery connection decal</p>		<p>39. Decal-Charging harness decal</p>	
<p>18. Decal-Battery as counterweight warning</p>		<p>40. Decal-Unbraking indication</p>	
<p>19. Decal-Turn off the power</p>		<p>41. Decal-Platform power cable decal</p>	
<p>20. Decal-Battery side decal</p>		<p>42. Decal-HV32 hyd oil decal</p>	
<p>21. Decal-ELEC shock fire warning</p>		<p>43. Decal-No mixing of hyd oil (English)</p>	<p>It's not recommended to mix hydraulic oil of different types, grades and/or brand.</p>





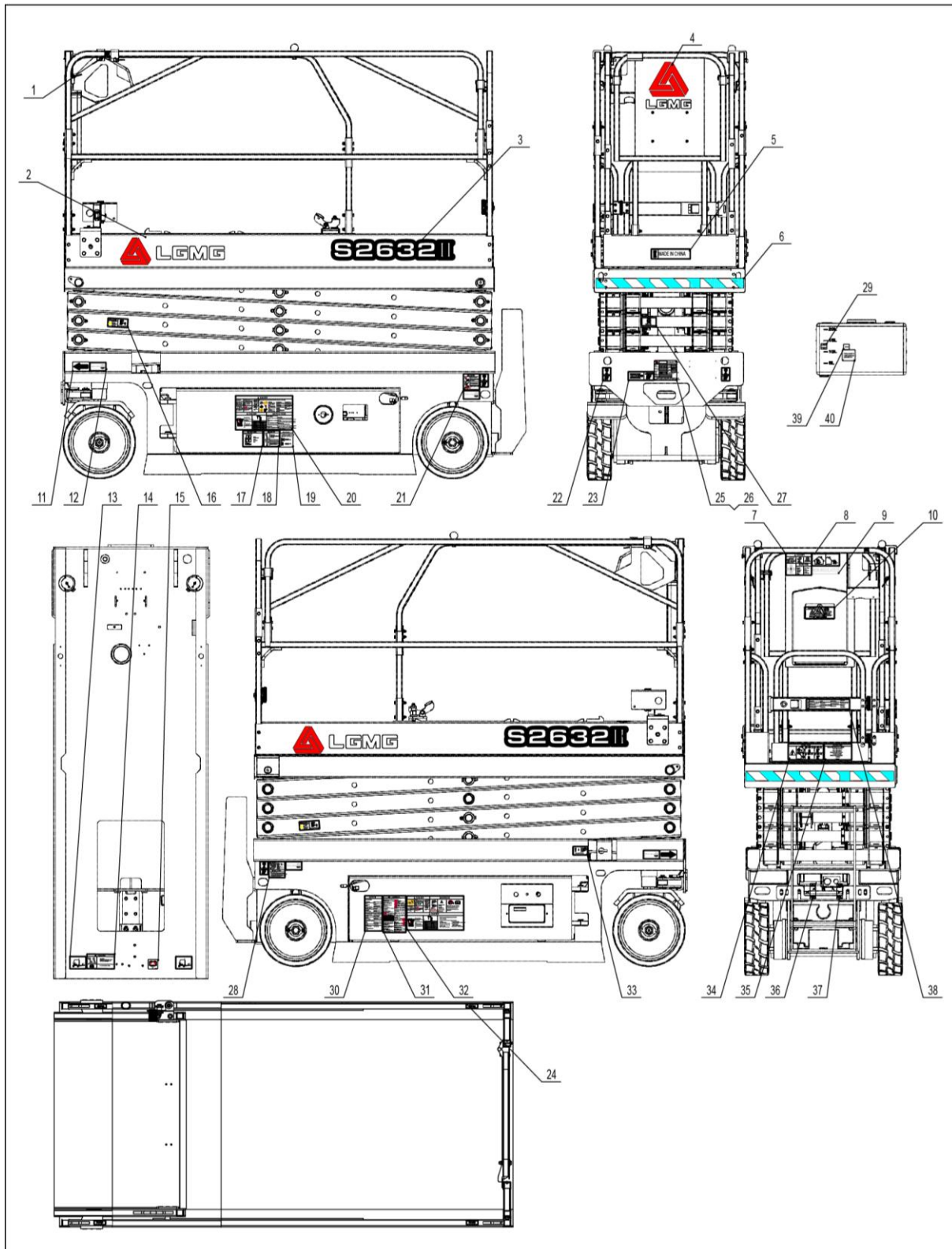







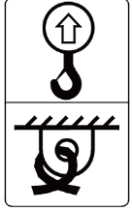

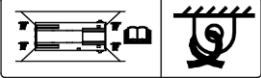
S2632 II Decals



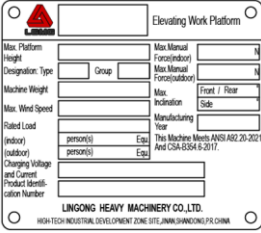
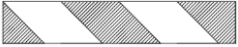

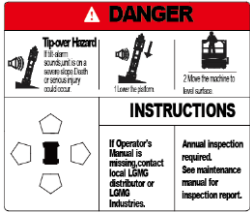







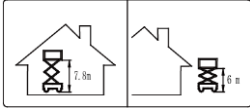

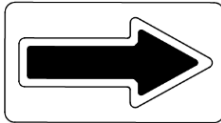

Operation Manual of Scissors Mobile Elevating Work Platform

Name	Decal	Name	Decal
1. Decal-Suspension position		21. RIVET GB12618.4-4.8*16	
2. Decal-Model S2632 II		22. Decal-Fork safety arm decal	
3. Decal-LOGO-High 240		23. Decal-Brake release safety warning	
4. Decal-Country of origin decal		24. Decal-Oil level decal	
5. Warning wire		25. Decal-Emergency descent decal	
6. Decal-Precautions		27. Decal-Max. manual force decal	
7. Decal-Toggle alert		28. Decal-Operating instructions	

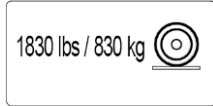
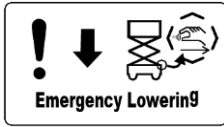

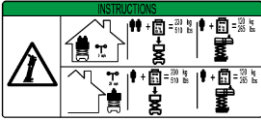
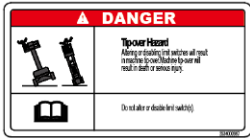
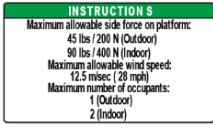
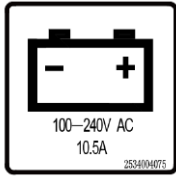





Operation Manual of Scissors Mobile Elevating Work Platform

<p>8.Decal-Manual</p>		<p>29.Decal-LOGO-High 130</p>	
<p>9.Decal-Travel direction</p>		<p>30.Decal-Fuel tank side decal</p>	
<p>10.Decal-Wheel load decal</p>		<p>31.Decal-Lifting decal</p>	
<p>11.Decal-Telehandler</p>		<p>32.Decal-FR column decal</p>	
<p>12.Decal-Risk of tipping</p>		<p>33.Decal-Transport</p>	
<p>13.Decal-Stay away from machine warning</p>		<p>34.Decal-Battery side decal</p>	
<p>14.Decal-Safety rules</p>		<p>35.Decal-Battery charging decal (10.5A)</p>	
<p>15.Decal-Battery connection decal</p>		<p>36.Decal-Non-insulating decal</p>	

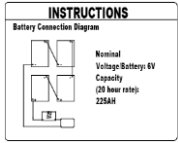
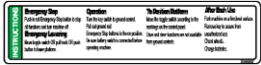
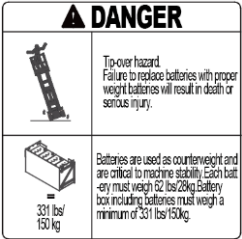

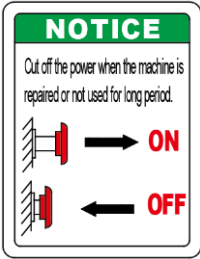
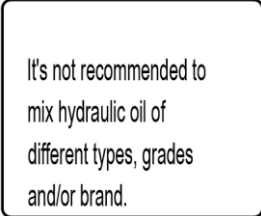
Operation Manual of Scissors Mobile Elevating Work Platform

<p>16. Decal-Battery as counterweight warning</p>		<p>37. Decal-HV32 hyd oil decal</p>	
<p>17. Decal-Turn off the power</p>		<p>38. Decal-No mixing of hyd oil (English)</p>	
<p>18. Decal-ELEC shock fire warning</p>		<p>39. Decal-Platform power cable decal</p>	
<p>19. Decal-Lanyard anchorage point</p>		<p>40. Decal-Charging harness decal</p>	
<p>20. Complete machine nameplate (ANSI)</p>			





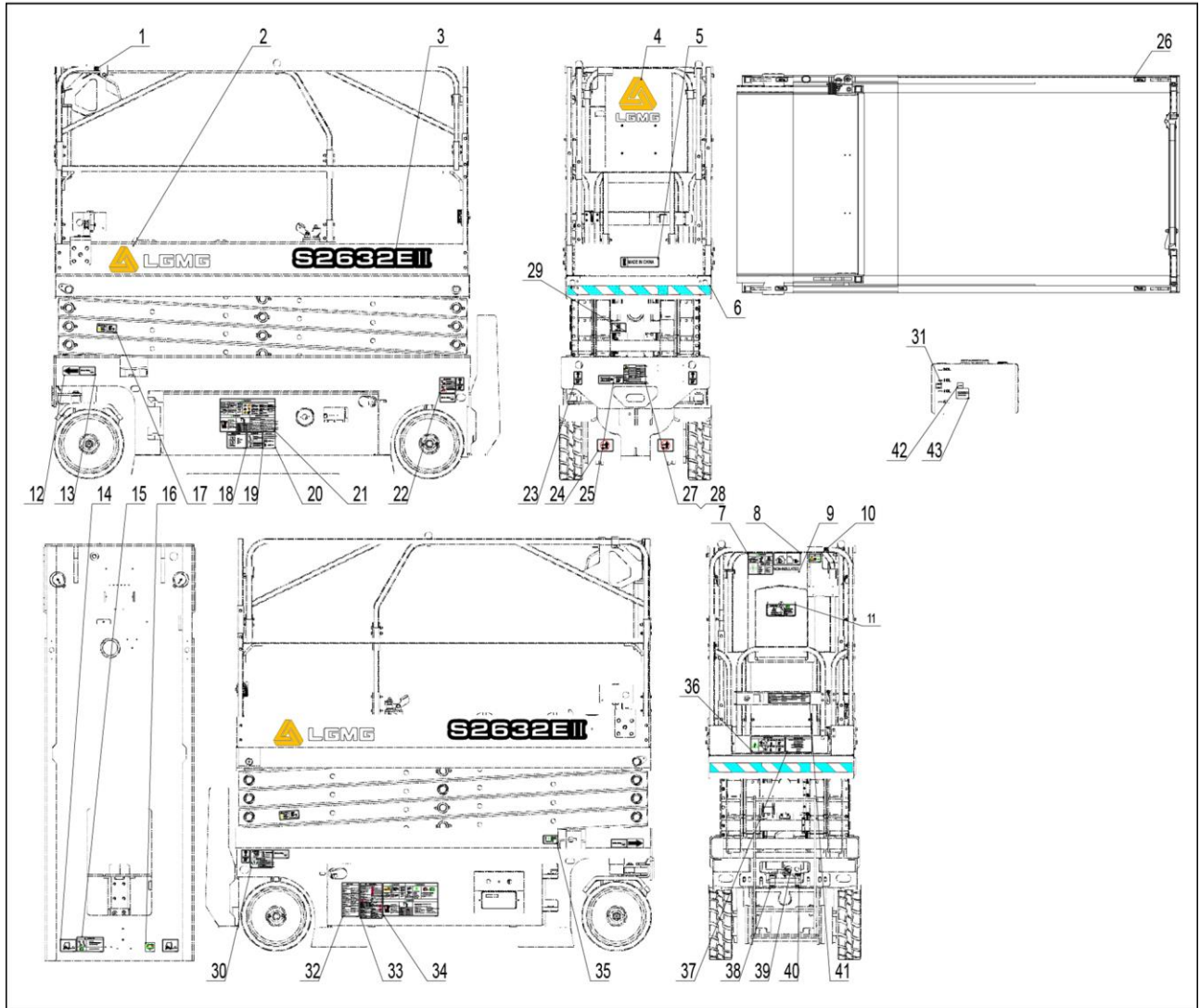





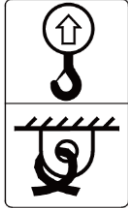

S2632E II Decals



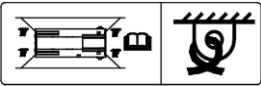

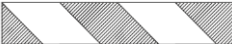
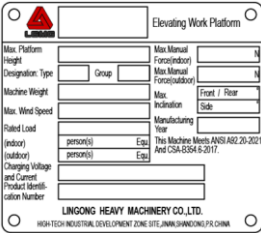
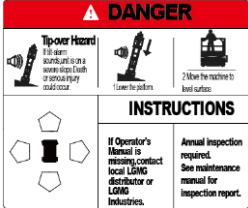







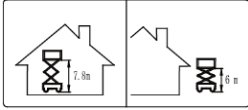



Operation Manual of Scissors Mobile Elevating Work Platform

Name	Decal	Name	Decal
1. Decal-Suspension position		22. Decal-ELEC shock fire warning	
2. Decal-LOGO-High 130		23. Decal-Lifting decal	
3. Decal-Model S2632E II		24. Decal-No water spraying decal	
4. Decal-LOGO-High 240		25. Decal-Transport	
5. Decal-Country of origin decal		26. Decal-Lanyard anchorage point	
6. Warning wire		27. Complete machine nameplate (ANSI)	
7. Decal-FR column decal		29. Decal-Fork safety arm decal	

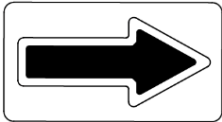

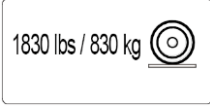

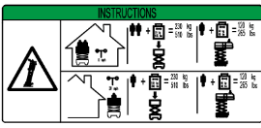
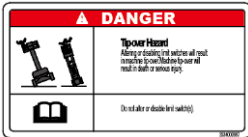
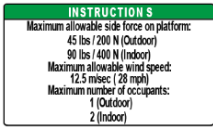





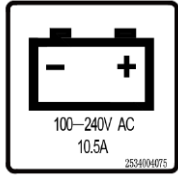

Operation Manual of Scissors Mobile Elevating Work Platform

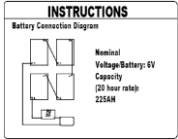
<p>8. Decal-Toggle alert</p>		<p>30. Decal-Brake release safety warning</p>	
<p>9. Decal-Non-insulating decal</p>		<p>31. Decal-Oil level decal</p>	
<p>10. Decal-Slope low speed warning</p>		<p>32. Decal-Precautions</p>	
<p>11. Decal-Manual</p>		<p>33. Decal-Safety rules</p>	
<p>12. Decal-Travel direction</p>		<p>34. Decal-Fuel tank side decal</p>	
<p>13. Decal-Wheel load decal</p>		<p>35. Decal-Emergency descent decal</p>	
<p>14. Decal-Telehandler</p>		<p>36. Decal-Platform security warning</p>	
<p>15. Decal-Risk of tipping</p>		<p>37. Decal-Max. manual force decal</p>	

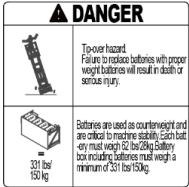
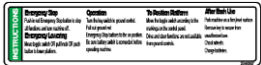
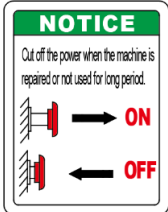

Operation Manual of Scissors Mobile Elevating Work Platform

<p>16. Decal-Battery charging decal (10.5A)</p>		<p>38. Decal-Charging harness decal</p>	
<p>17. Decal-Stay away from machine warning</p>		<p>39. Decal-Unbraking indication</p>	
<p>18. Decal-Battery connection decal</p>		<p>40. Decal-Platform power cable decal</p>	
<p>19. Decal-Battery as counterweight warning</p>		<p>41. Decal-Operating instructions</p>	
<p>20. Decal-Turn off the power</p>		<p>42. Decal-HV32 hyd oil decal</p>	
<p>21. Decal-Battery side decal</p>		<p>43. Decal-No mixing of hyd oil (English)</p>	





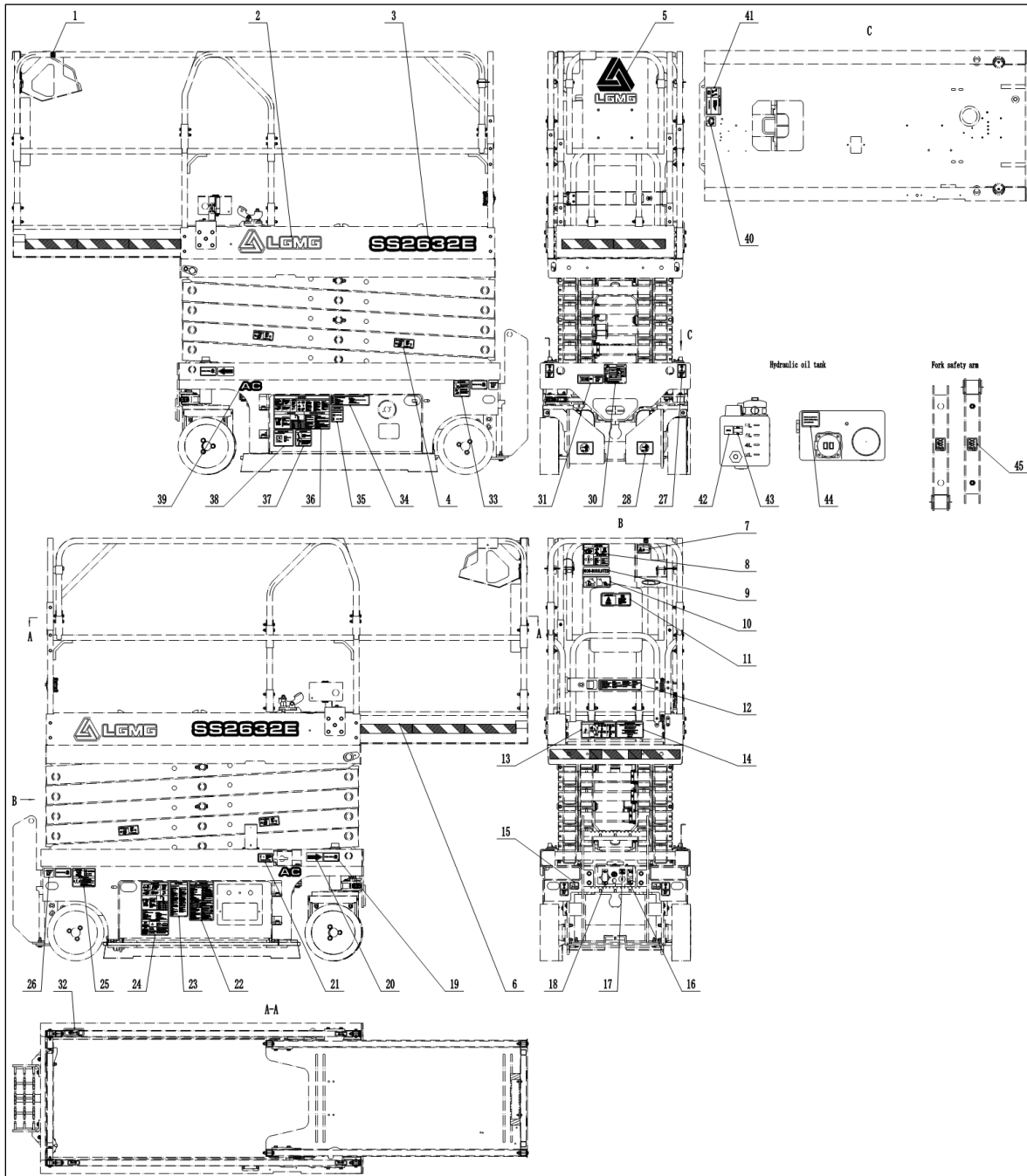











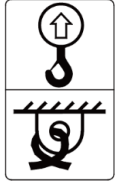
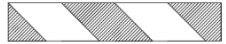

SS2632E Decals



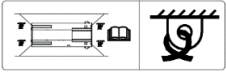

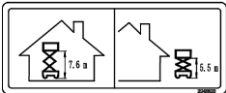
Operation Manual of Scissors Mobile Elevating Work Platform

Name	Decal	Name	Decal
1. Decal-Platform controls location		23. Decal-Notice	
2. Decal-LGMG logo		24. Decal-Hydraulic tank side decal	
3. Decal-Model SS2632E		25. Decal-Brake release safety warning	
4. Decal-Away from machine warning		26. Decal-Lifting lug	
5. Decal-LGMG logo		27. Decal-Lifting	
6. Decal-Warning strip		28. Decal-Do not spray water	
7. Decal-Drive at a low speed on slope		29. Machine nameplate (Mexico)	
8. Decal-Front guard rail decal		31. Decal-Transport tie-down	
9. Decal-Non-insulated		32. Decal-Lanyard attachment point	
10. Decal-Switch warning		33. Decal-Electrocution/fire hazard	





Operation Manual of Scissors Mobile Elevating Work Platform

11. Decal-Read the manual		34. Decal-Danger	
12. Decal-Operating instructions		35. Decal-Power on/off	
13. Decal-Platform safety warning		36. Decal-Battery side decal	
14. Decal-Maximum manual force		37. Decal-Battery as counterweight	
15. Decal-Forklift pocket		38. Decal-Battery connection instructions	
16. Decal-Power cable to platform		39. Decal-Alternating current	
17. Decal-Brake release		40. Decal-Battery charging	
18. Decal-Charging harness		41. Decal-Tip-over hazard	
19. Decal-Wheel load		42. Decal-HV32 Hydraulic oil	
20. Decal-Forward direction		43. Decal-Oil level	

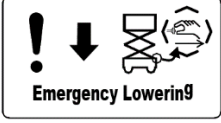
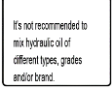

Operation Manual of Scissors Mobile Elevating Work Platform

21. Decal-Emergency lowering	 <p>Emergency Lowering</p>	44. Decal-Do not mix hydraulic oils	 <p>It's not recommended to mix hydraulic oil of different types, grades and/or brand.</p>
22. Decal-Safety rules		45. Decal-Safety arm	 <p>Safety Arm</p>



S2646E Decal Diagram

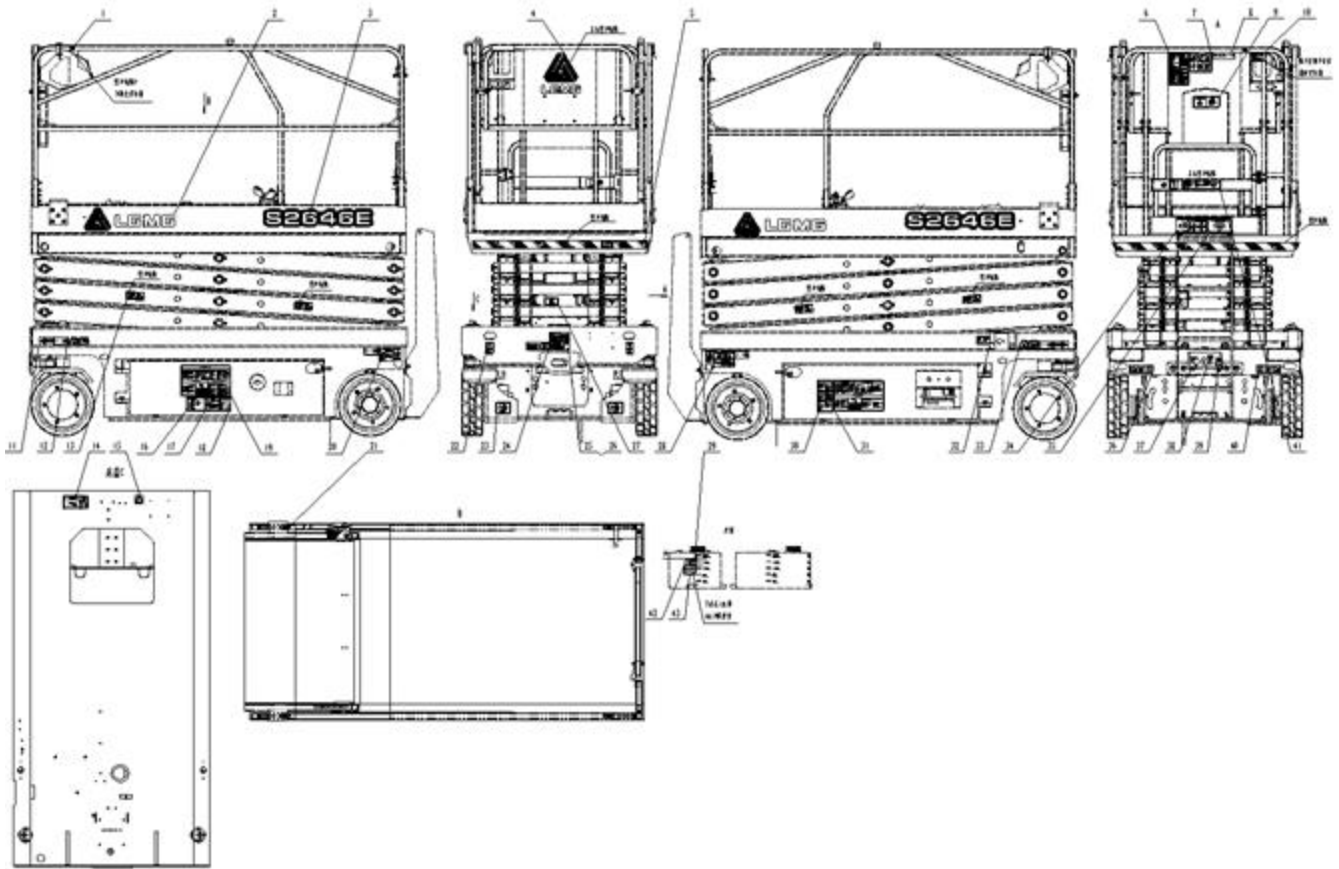



S2646E Decal List

Item	Description	Item	Description
1	Decal-Platform controls location	24	Decal-Transport
2	Decal-Company Logo	25	Decal-Machine nameplate
3	Decal-Model	26	RIVET
4	Decal-Company Logo	27	Decal-Fork safety arm
5	Decal-Warning line	28	Decal-Brake release safety warning
6	Decal-Safety rules	29	Decal-Oil level
7	Decal-Front guardrail decal	30	Decal-Precautions
8	Decal-Non-insulated	31	Decal-Oil tank side
9	Decal-Read the manual	32	Decal-Emergency lowering
10	Decal-Slow speed	33	Decal-Alternating current
11	Decal-Travel direction	34	Decal-Platform safety warning
12	Decal-Wheel load	35	Decal-Maximum manual force
13	Decal-Away from the machine	36	Decal-Telehandler (LH)
14	Decal-Risk of tipping	37	Decal-Charging harness
15	Decal-Battery charging	38	Decal-Brake release instructions
16	Decal-Battery connection decal	39	Decal-Power cable to platform
17	Decal-Battery as counterweight warning	40	Decal-Telehandler (RH)
18	Decal-Turn off power	41	Decal-Warning, Platform safety
19	Decal-Battery side decal	42	DECAL-HV32 HYD OIL DECAL
20	Decal-ELEC shock fire warning	43	Decal-No mixing of hyd oil
21	Decal-Lanyard anchorage point	44	
22	Decal-Lifting	45	
23	Decal-No spray	46	



Operation Manual of Scissors Mobile Elevating Work Platform

S2646E Decals

1 	2 	3 	4 	5 	6
7 	8 	9 	10 	11 	12
13 	14 	15 	16 	17 	18
19 	20 	21 	22 	23 	24
25 	26 	27 	28 	29 	30
31 	32 	33 	34 	35 	36
37 	38 	39 	40 	41 	42
43 					



S2646 II Decal Diagram

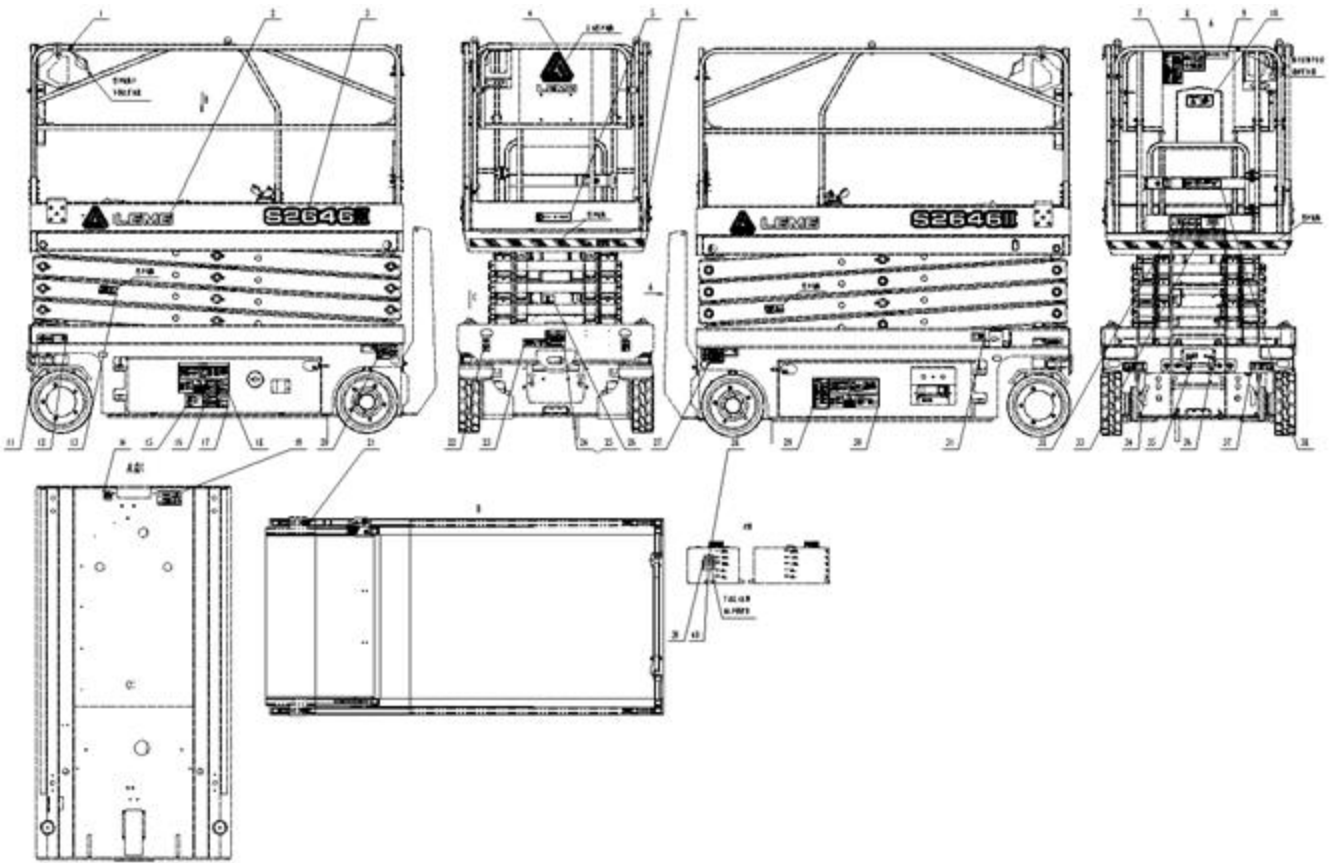





















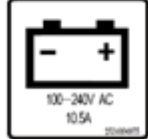

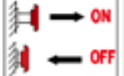



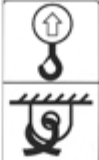



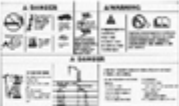

S2646 II Decal List

Item	Description	Item	Description
1	Decal-Platform controls location	24	Decal-Machine nameplate
2	Decal-Company Logo	25	RIVET
3	Decal-Model	26	Decal-Fork safety arm
4	Decal-Company Logo	27	Decal-Brake release safety warning
5	Decal-Country of origin decal	28	Decal-Oil level
6	Decal-Warning line	29	Decal-Precautions
7	Decal-Safety rules	30	Decal-Oil tank side
8	Decal-Front guardrail decal	31	Decal-Emergency lowering
9	Decal-Non-insulated	32	Decal-Platform safety warning
10	Decal-Read the manual	33	Decal-Maximum manual force
11	Decal-Travel direction	34	Decal-Telehandler (LH)
12	Decal-Wheel load	35	Decal-Charging harness
13	Decal-Away from the machine	36	Decal-Power cable to platform
14	Decal-Battery charging	37	Decal-Telehandler (RH)
15	Decal-Battery connection decal	38	Decal-Warning, Platform safety
16	Decal-Battery as counterweight warning	39	DECAL-HV32 HYD OIL DECAL
17	Decal-Turn off power	40	Decal-No mixing of hyd oil
18	Decal-Battery side decal	41	
19	Decal-Risk of tipping	42	
20	Decal-ELEC shock fire warning	43	
21	Decal-Lanyard anchorage point	44	
22	Decal-Lifting	45	
23	Decal-Transport	46	



S2646 II Decals

1  Platform Controls Location	2  LGMG	3 S2646 II	4  LGMG	5 	6 
7 	8 	9 NON-INSULATED	10 	11 	12  1322lbs/600kg
13 	14  100-240V AC 10.5A	15 INSTRUCTIONS Battery Connection Diagram  Revised Battery/Battery HV Capacity (28 hour cycle) 255Ah	16 INSTRUCTIONS Battery Connection Diagram  Revised Battery/Battery HV Capacity (28 hour cycle) 255Ah	17 NOTICE Cut off the power when the machine is repaired to avoid any accident. 	18 
19 	20 	21 	22 	23 	24 
25	26  Safety Arm	27 	28 Max Min	29 	30 
31  Emergency Lowering	32 	33 INSTRUCTIONS Maximum allowable side force on platform: 40 lbs (20 N) (Classical) 50 lbs (22 N) (Standard) Maximum allowable wind speed: 15.5 mph (7 m/s) Nominal number of hoists: 1 (Classical) 2 (Standard)	34 	35 	36 
37 	38 	39 HV32	40 It's not recommended to mix hydraulic oil of different types, grades and/or brand.	41	42



S2646E II Decal Diagram

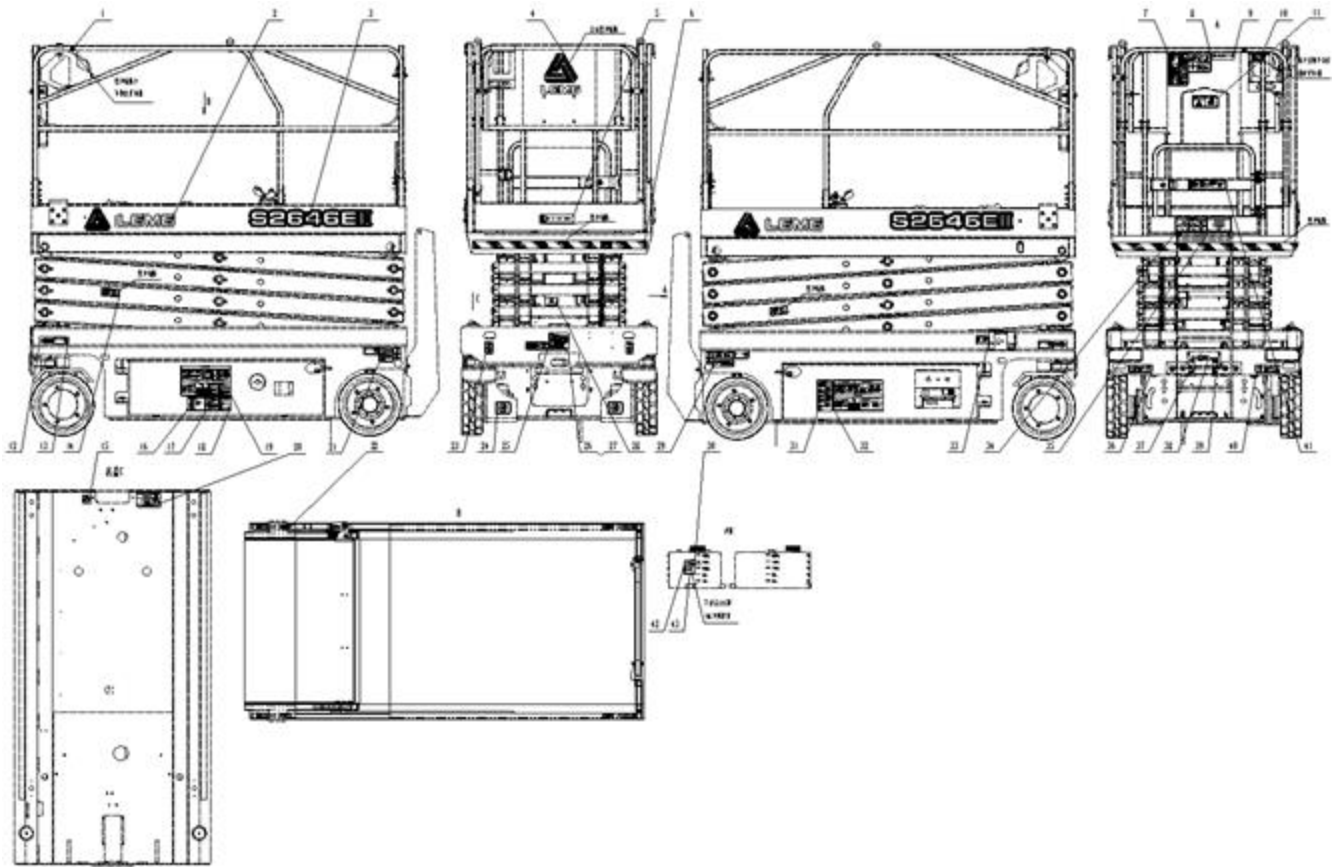



















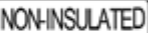













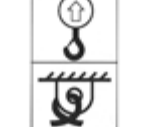









S2646E II Decal List

Item	Description	Item	Description
1	Decal-Platform controls location	24	Decal-No spray
2	Decal-Company Logo	25	Decal-Transport
3	Decal-Model	26	Decal-Machine nameplate
4	Decal-Company Logo	27	RIVET
5	Decal-Country of origin decal	28	Decal-Fork safety arm
6	Decal-Warning line	29	Decal-Brake release safety warning
7	Decal-Safety rules	30	Decal-Oil level
8	Decal-Front guardrail decal	31	Decal-Precautions
9	Decal-Non-insulated	32	Decal-Oil tank side
10	Decal-Slow speed	33	Decal-Emergency lowering
11	Decal-Read the manual	34	Decal-Platform safety warning
12	Decal-Travel direction	35	Decal-Maximum manual force
13	Decal-Wheel load	36	Decal-Telehandler (LH)
14	Decal-Away from the machine	37	Decal-Charging harness
15	Decal-Battery charging	38	Decal-Brake release instructions
16	Decal-Battery connection decal	39	Decal-Power cable to platform
17	Decal-Battery as counterweight warning	40	Decal-Telehandler (RH)
18	Decal-Turn off power	41	Decal-Warning, Platform safety
19	Decal-Battery side decal	42	DECAL-HV32 HYD OIL DECAL
20	Decal-Risk of tipping	43	Decal-No mixing of hyd oil
21	Decal-ELEC shock fire warning	44	
22	Decal-Lanyard anchorage point	45	
23	Decal-Lifting	46	



Operation Manual of Scissors Mobile Elevating Work Platform

S2646E II Decals

1  Platform Controls Location	2 	3	4 	5 	6 
7 	8 	9 	10 	11 	12 
13 	14 	15 	16 	17 	18 
19 	20 	21 	22 	23 	24 
25 	26 	27	28 	29 	30 
31 	32 	33 	34 	35 	36 
37 	38 	39 	40 	41 	42 
43 					



S3246E Decal Diagram

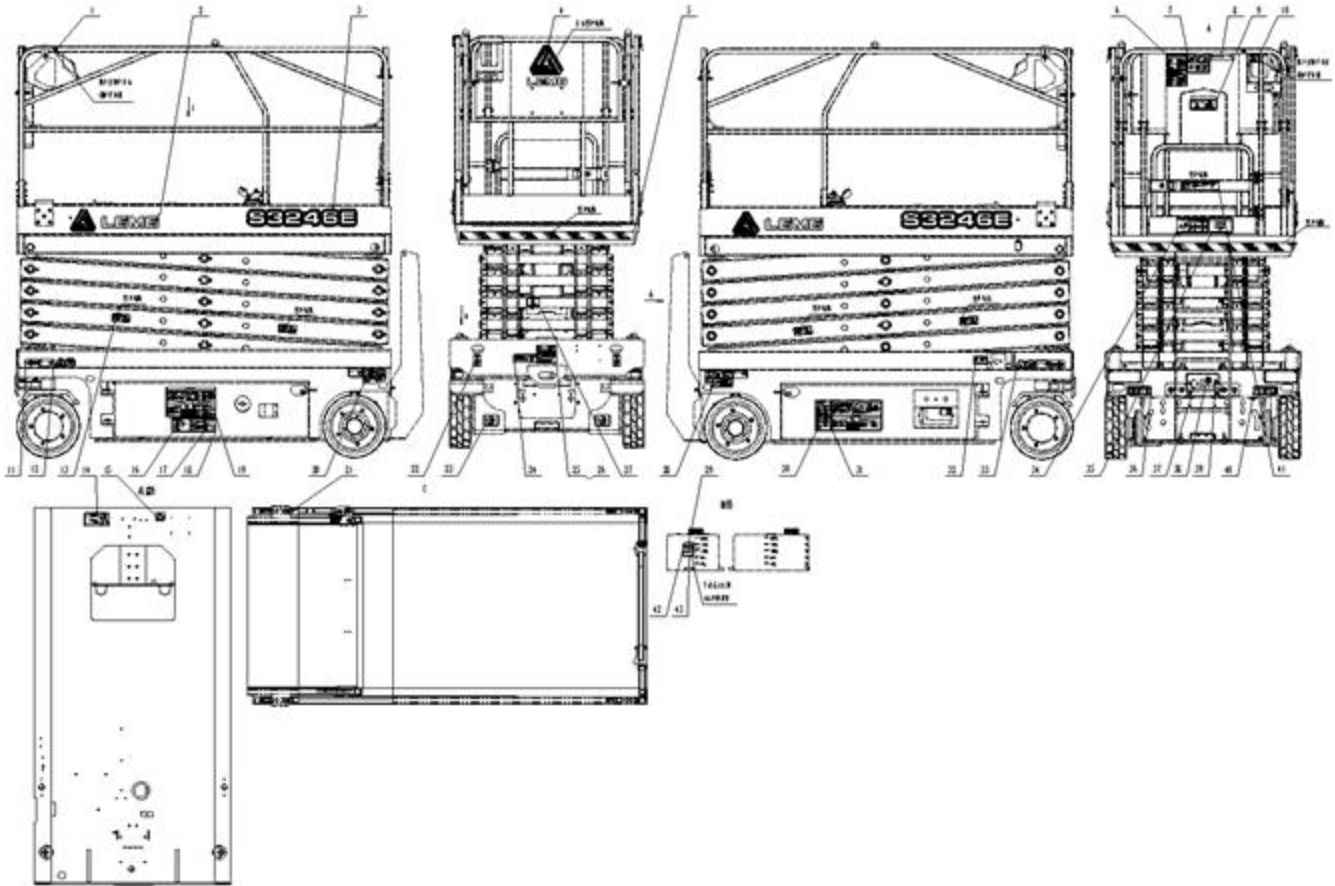



S3246E Decal List

Item	Description	Item	Description
1	Decal-Platform controls location	24	Decal-Transport
2	Decal-Company Logo	25	Decal-Machine nameplate
3	Decal-Model	26	RIVET
4	Decal-Company Logo	27	Decal-Fork safety arm
5	Decal-Warning line	28	Decal-Brake release safety warning
6	Decal-Safety rules	29	Decal-Oil level
7	Decal-Front guardrail decal	30	Decal-Precautions
8	Decal-Non-insulated	31	Decal-Oil tank side
9	Decal-Read the manual	32	Decal-Emergency lowering
10	Decal-Slow speed	33	Decal-Alternating current
11	Decal-Travel direction	34	Decal-Platform safety warning
12	Decal-Wheel load	35	Decal-Maximum manual force
13	Decal-Away from the machine	36	Decal-Telehandler (LH)
14	Decal-Risk of tipping	37	Decal-Charging harness
15	Decal-Battery charging	38	Decal-Brake release instructions
16	Decal-Battery connection decal	39	Decal-Power cable to platform
17	Decal-Battery as counterweight warning	40	Decal-Telehandler (RH)
18	Decal-Turn off power	41	Decal-Warning, Platform safety
19	Decal-Battery side decal	42	DECAL-HV32 HYD OIL DECAL
20	Decal-ELEC shock fire warning	43	Decal-No mixing of hyd oil
21	Decal-Lanyard anchorage point	44	
22	Decal-Lifting	45	
23	Decal-No spray	46	



Operation Manual of Scissors Mobile Elevating Work Platform

S3246E Decals

1 	2 	3	4 	5 	6
7 	8 	9 	10 	11 	12
13 	14 	15 	16 	17 	18
19 	20 	21 	22 	23 	24
25 	26	27 	28 	29 	30
31 	32 	33 	34 	35 	36
37 	38 	39 	40 	41 	42
43 					



S3246 II Decal Diagram

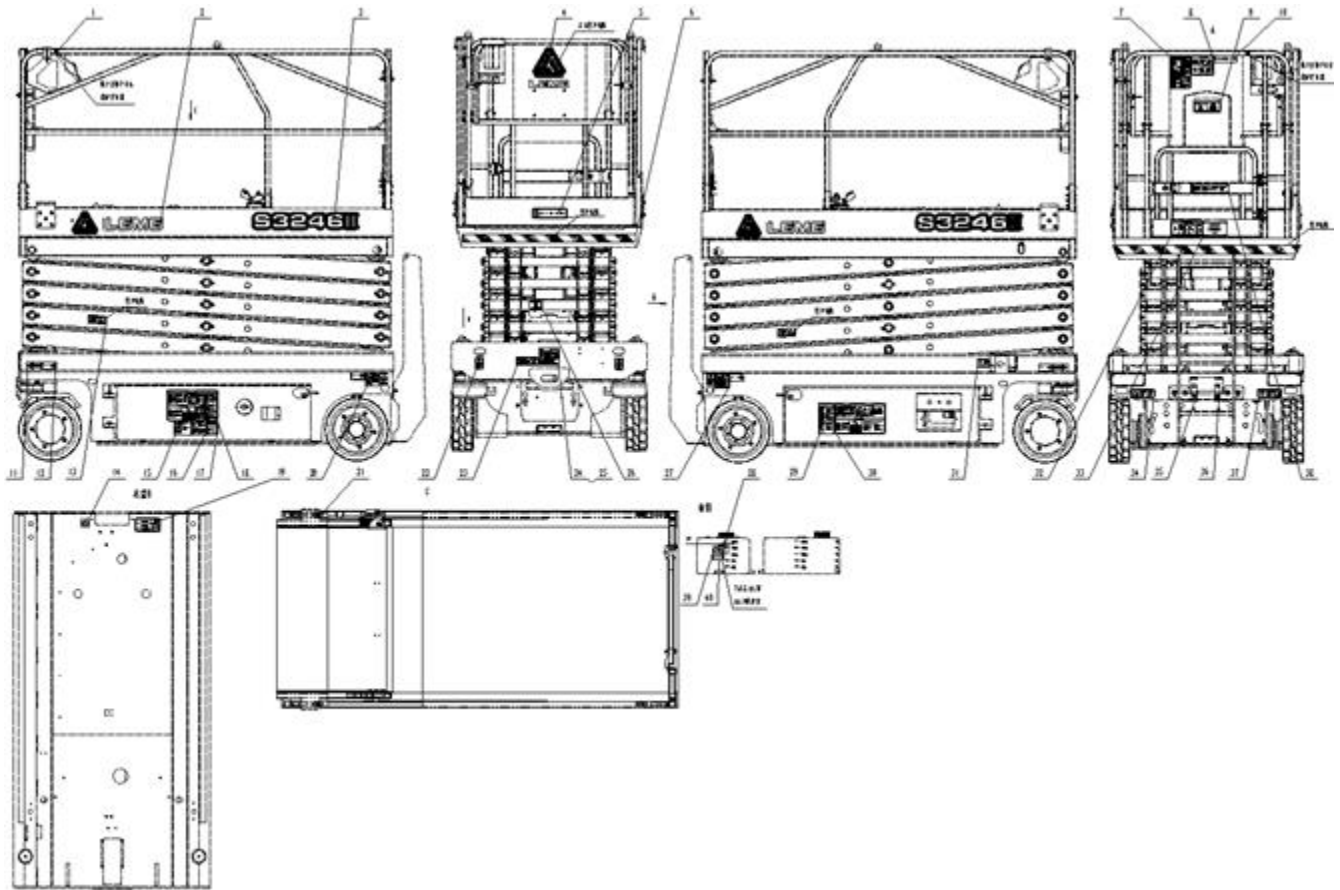



























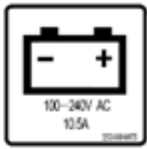



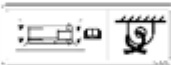









S3246 II Decal List

Item	Description	Item	Description
1	Decal-Platform controls location	24	Decal-Machine nameplate
2	Decal-Company Logo	25	RIVET
3	Decal-Model	26	Decal-Fork safety arm
4	Decal-Company Logo	27	Decal-Brake release safety warning
5	Decal-Country of origin decal	28	Decal-Oil level
6	Decal-Warning line	29	Decal-Precautions
7	Decal-Safety rules	30	Decal-Oil tank side
8	Decal-Front guardrail decal	31	Decal-Emergency lowering
9	Decal-Read the manual	32	Decal-Platform safety warning
10	Decal-Non-insulated	33	Decal-Maximum manual force
11	Decal-Travel direction	34	Decal-Telehandler (LH)
12	Decal-Wheel load	35	Decal-Charging harness
13	Decal-Away from the machine	36	Decal-Power cable to platform
14	Decal-Battery charging	37	Decal-Telehandler (RH)
15	Decal-Battery connection decal	38	Decal-Warning, Platform safety
16	Decal-Battery as counterweight warning	39	DECAL-HV32 HYD OIL DECAL
17	Decal-Turn off power	40	Decal-No mixing of hyd oil
18	Decal-Battery side decal	41	
19	Decal-Risk of tipping	42	
20	Decal-ELEC shock fire warning	43	
21	Decal-Lanyard anchorage point	44	
22	Decal-Lifting	45	
23	Decal-Transport	46	

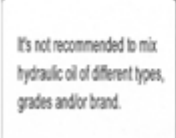

S3246 II Decals

1 	2 	3 	4 	5 	6 
7 	8 	9 	10 	11 	12 
13 	14 	15 	16 	17 	18 
19 	20 	21 	22 	23 	24 
25 	26 	27 	28 	29 	30 
31 	32 	33 	34 	35 	36 
37 	38 	39 	40 	41 	42 



S3246E II Decal Diagram

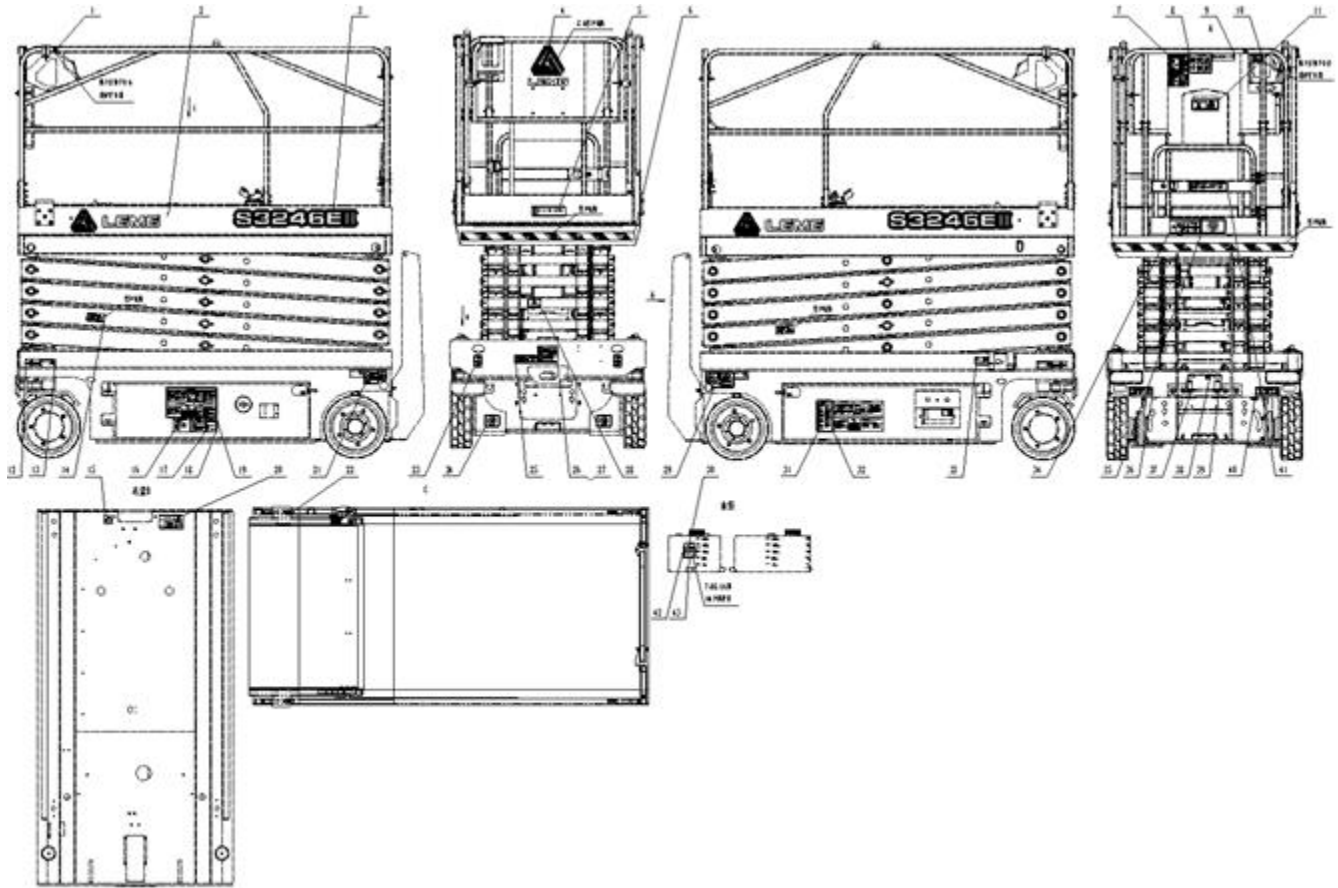





















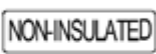













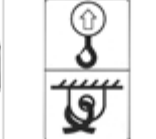

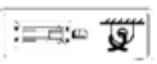





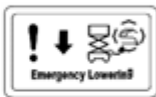

S3246E II Decal List

Item	Description	Item	Description
1	Decal-Platform controls location	24	Decal-No spray
2	Decal-Company Logo	25	Decal-Transport
3	Decal-Model	26	Decal-Machine nameplate
4	Decal-Company Logo	27	RIVET
5	Decal-Country of origin decal	28	Decal-Fork safety arm
6	Decal-Warning line	29	Decal-Brake release safety warning
7	Decal-Safety rules	30	Decal-Oil level
8	Decal-Front guardrail decal	31	Decal-Precautions
9	Decal-Non-insulated	32	Decal-Oil tank side
10	Decal-Slow speed	33	Decal-Emergency lowering
11	Decal-Read the manual	34	Decal-Platform safety warning
12	Decal-Travel direction	35	Decal-Maximum manual force
13	Decal-Wheel load	36	Decal-Telehandler (LH)
14	Decal-Away from the machine	37	Decal-Charging harness
15	Decal-Battery charging	38	Decal-Brake release instructions
16	Decal-Battery connection decal	39	Decal-Power cable to platform
17	Decal-Battery as counterweight warning	40	Decal-Telehandler (RH)
18	Decal-Turn off power	41	Decal-Warning, Platform safety
19	Decal-Battery side decal	42	DECAL-HV32 HYD OIL DECAL
20	Decal-Risk of tipping	43	Decal-No mixing of hyd oil
21	Decal-ELEC shock fire warning	44	
22	Decal-Lanyard anchorage point	45	
23	Decal-Lifting	46	

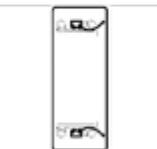

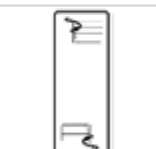
Operation Manual of Scissors Mobile Elevating Work Platform

S3246E II Decals

1 	2 	3 	4 	5 	6 
7 	8 	9 	10 	11 	12 
13 	14 	15 	16 	17 	18 
19 	20 	21 	22 	23 	24 
25 	26 	27 	28 	29 	30 
31 	32 	33 	34 	35 	36 
37 	38 	39 	40 	41 	42 
43 					



S4046E Decals

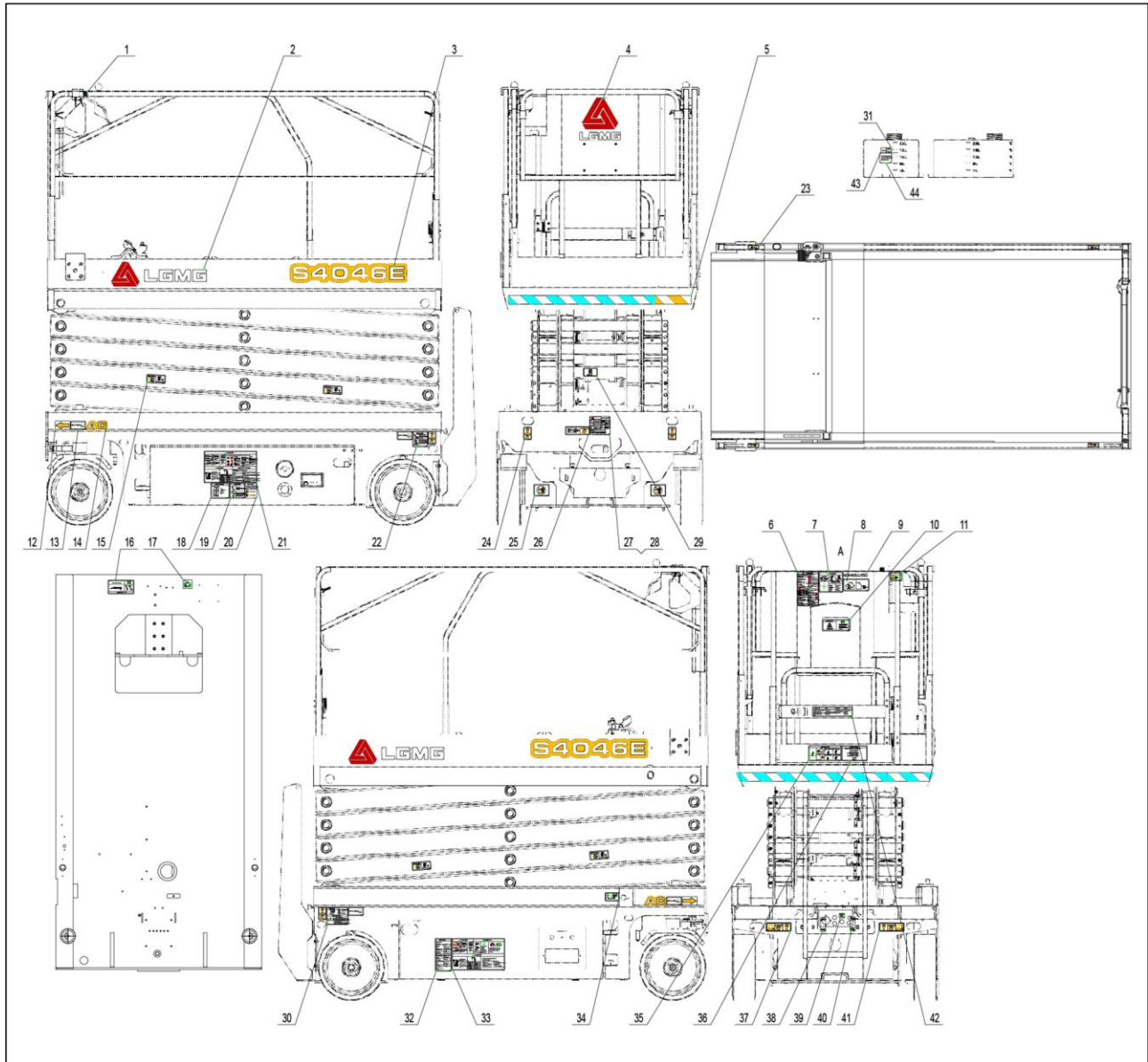



Operation Manual of Scissors Mobile Elevating Work Platform

Name	Decal	Name	Decal
1. Decal-Suspension position		23. Decal-Lanyard anchorage point	
2. Decal-LOGO-High 130		24. Decal-Lifting decal	
3. Decal-Model S4046E		25. Decal-No water spraying decal	
4. Decal-LOGO-High 240		26. Decal-Transport	
5. Warning wire		27. Complete machine nameplate (Mexico)	
6. Decal-Safety rules		29. Decal-Fork safety arm decal	



Operation Manual of Scissors Mobile Elevating Work Platform

<p>7. Decal-FR column decal</p>		<p>30. Decal-Brake release safety warning</p>	
<p>8. Decal-Toggle alert</p>		<p>31. Decal-Oil level decal</p>	
<p>9. Decal-Non-insulating decal</p>		<p>32. Decal-Precautions</p>	
<p>10. Decal-Manual</p>		<p>33. Decal-Fuel tank side decal</p>	
<p>11. Decal-Slope low speed warning</p>		<p>34. Decal-Emergency descent decal</p>	
<p>12. Decal-Travel direction</p>		<p>35. Decal-Platform security warning</p>	
<p>13. Decal-Wheel load decal</p>		<p>36. Decal-Max. manual force decal</p>	
<p>14. Decal-Alternating current decal</p>		<p>37. Decal-Telehandler (LH)</p>	



Operation Manual of Scissors Mobile Elevating Work Platform

<p>15. Decal-Stay away from machine warning</p>		<p>38. Decal-Charging harness decal</p>	
<p>16. Decal-Risk of tipping</p>		<p>39. Decal-Unbraking indication</p>	
<p>17. Decal-Battery charging decal (10.5A)</p>		<p>40. Decal-Platform power cable decal</p>	
<p>18. Decal-Battery connection decal</p>		<p>41. Decal-Telehandler (RH)</p>	
<p>19. Decal-Battery as counterweight warning</p>		<p>42. Decal-Operating instructions</p>	
<p>20. Decal-Turn off the power</p>		<p>43. Decal-HV32 hyd oil decal</p>	
<p>21. Decal-Battery side decal</p>		<p>44. Decal-No mixing of hyd oil (English)</p>	<p>It's not recommended to mix hydraulic oil of different types, grades and/or brand.</p>
<p>22. Decal-ELEC shock fire warning</p>			





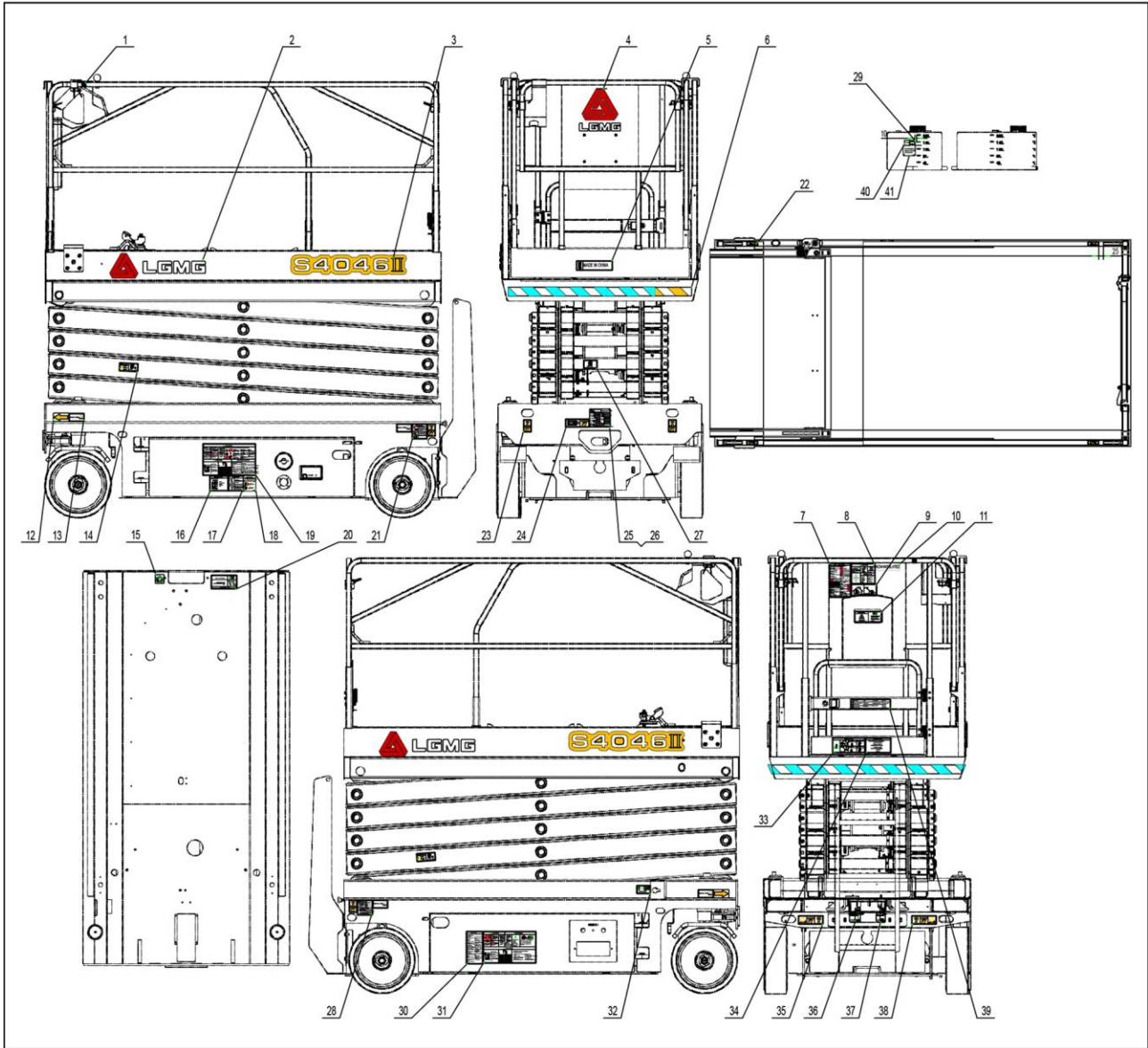





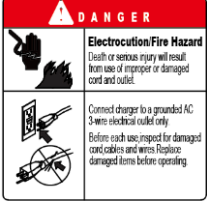

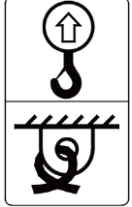

S4046 II Decals

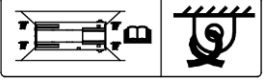

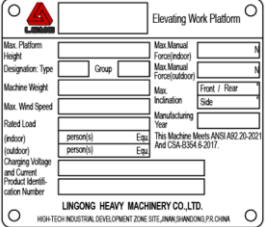
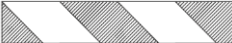

Operation Manual of Scissors Mobile Elevating Work Platform

Name	Decal	Name	Decal
1. Decal-Suspension position		21. Decal-ELEC shock fire warning	
2. Decal-LOGO-High 130		22. Decal-Lanyard anchorage point	
3. Decal-Model S4046 II		23. Decal-Lifting decal	
4. Decal-LOGO-High 240		24. Decal-Transport	
5. Decal-Country of origin decal		25. Complete machine nameplate (ANSI)	
6. Warning wire		27. Decal-Fork safety arm decal	
7. Decal-Safety rules		28. Decal-Brake release safety warning	



Operation Manual of Scissors Mobile Elevating Work Platform

<p>8. Decal-FR column decal</p>		<p>29. Decal-Oil level decal</p>	
<p>9. Decal-Toggle alert</p>		<p>30. Decal-Precautions</p>	
<p>10. Decal-Non-insulating decal</p>		<p>31. Decal-Fuel tank side decal</p>	
<p>11. Decal-Manual</p>		<p>32. Decal-Emergency descent decal</p>	
<p>12. Decal-Travel direction</p>		<p>33. Decal-Platform security warning</p>	
<p>13. Decal-Wheel load decal</p>		<p>34. Decal-Max. manual force decal</p>	
<p>14. Decal-Stay away from machine warning</p>		<p>35. Decal-Telehandler (LH)</p>	
<p>15. Decal-Battery charging decal (10.5A)</p>		<p>36. Decal-Charging harness decal</p>	



Operation Manual of Scissors Mobile Elevating Work Platform

<p>16. Decal-Battery connection decal</p>		<p>37. Decal-Platform power cable decal</p>	
<p>17. Decal-Battery as counterweight warning</p>		<p>38. Decal-Telehandler (RH)</p>	
<p>18. Decal-Turn off the power</p>		<p>39. Decal-Operating instructions</p>	
<p>19. Decal-Battery side decal</p>		<p>40. Decal-HV32 hyd oil decal</p>	<div style="border: 1px solid black; padding: 10px; text-align: center;"> <h1 style="margin: 0;">HV32</h1> </div>
<p>20. Decal-Risk of tipping</p>		<p>41. Decal-No mixing of hyd oil (English)</p>	<div style="border: 1px solid black; padding: 10px;"> <p>It's not recommended to mix hydraulic oil of different types, grades and/or brand.</p> </div>



S4046E II Decals

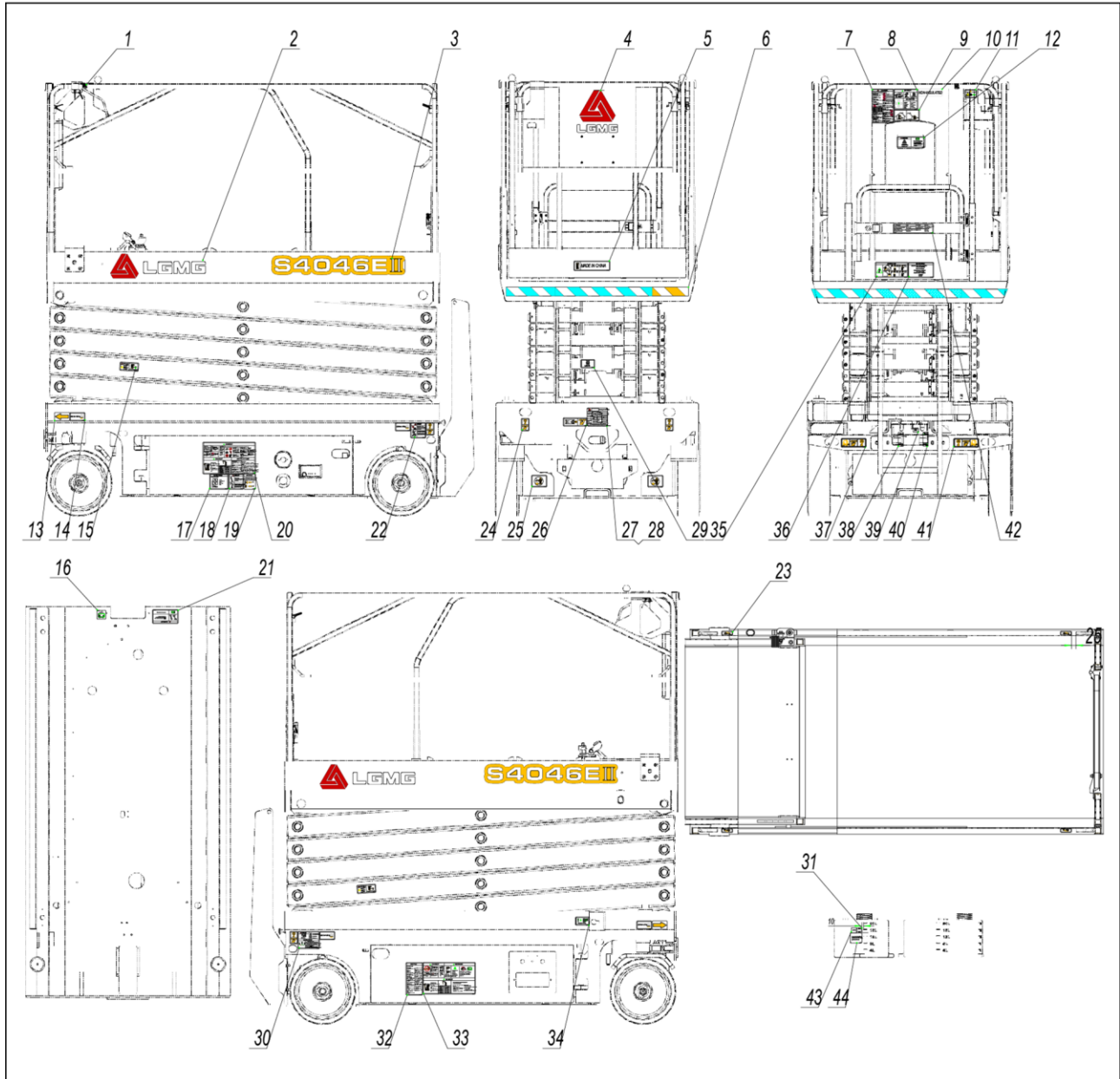



Operation Manual of Scissors Mobile Elevating Work Platform

Name	Decal	Name	Decal
1. Decal-Suspension position		23. Decal-Lanyard anchorage point	
2. Decal-LOGO-High 130		24. Decal-Lifting decal	
3. Decal-Model S4046E II		25. Decal-No water spraying decal	
4. Decal-LOGO-High 240		26. Decal-Transport	
5. Decal-Country of origin decal		27. Complete machine nameplate	
6. Warning wire		29. Decal-Fork safety arm decal	
7. Decal-Safety rules		30. Decal-Brake release safety warning	











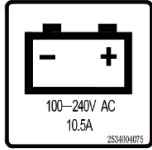

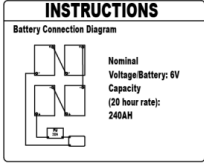
Operation Manual of Scissors Mobile Elevating Work Platform

<p>8. Decal-FR column decal</p>		<p>31. Decal-Oil level decal</p>	
<p>9. Decal-Toggle alert</p>		<p>32. Decal-Precautions</p>	
<p>10. Decal-Non-insulating decal</p>		<p>33. Decal-Fuel tank side decal</p>	
<p>11. Decal-Slope low speed warning</p>		<p>34. Decal-Emergency descent decal</p>	
<p>12. Decal-Manual</p>		<p>35. Decal-Platform security warning</p>	
<p>13. Decal-Travel direction</p>		<p>36. Decal-Max. manual force decal</p>	
<p>14. Decal-Wheel load decal</p>		<p>37. Decal-Telehandler (LH)</p>	
<p>15. Decal-Stay away from machine warning</p>		<p>38. Decal-Charging harness decal</p>	

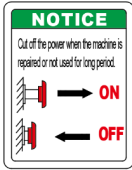
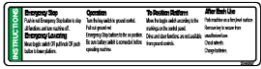

Operation Manual of Scissors Mobile Elevating Work Platform

<p>16. Decal-Battery charging decal (10.5A)</p>		<p>39. Decal-Unbraking indication</p>	
<p>17. Decal-Battery connection decal</p>		<p>40. Decal-Platform power cable decal</p>	
<p>18. Decal-Battery as counterweight warning</p>		<p>41. Decal-Telehandler (RH)</p>	
<p>19. Decal-Turn off the power</p>		<p>42. Decal-Operating instructions</p>	
<p>20. Decal-Battery side decal</p>		<p>43. Decal-HV32 hyd oil decal</p>	
<p>21. Decal-Risk of tipping</p>		<p>44. Decal-No mixing of hyd oil (English)</p>	<p>It's not recommended to mix hydraulic oil of different types, grades and/or brand.</p>
<p>22. Decal-ELEC shock fire warning</p>			



S4650E Decals

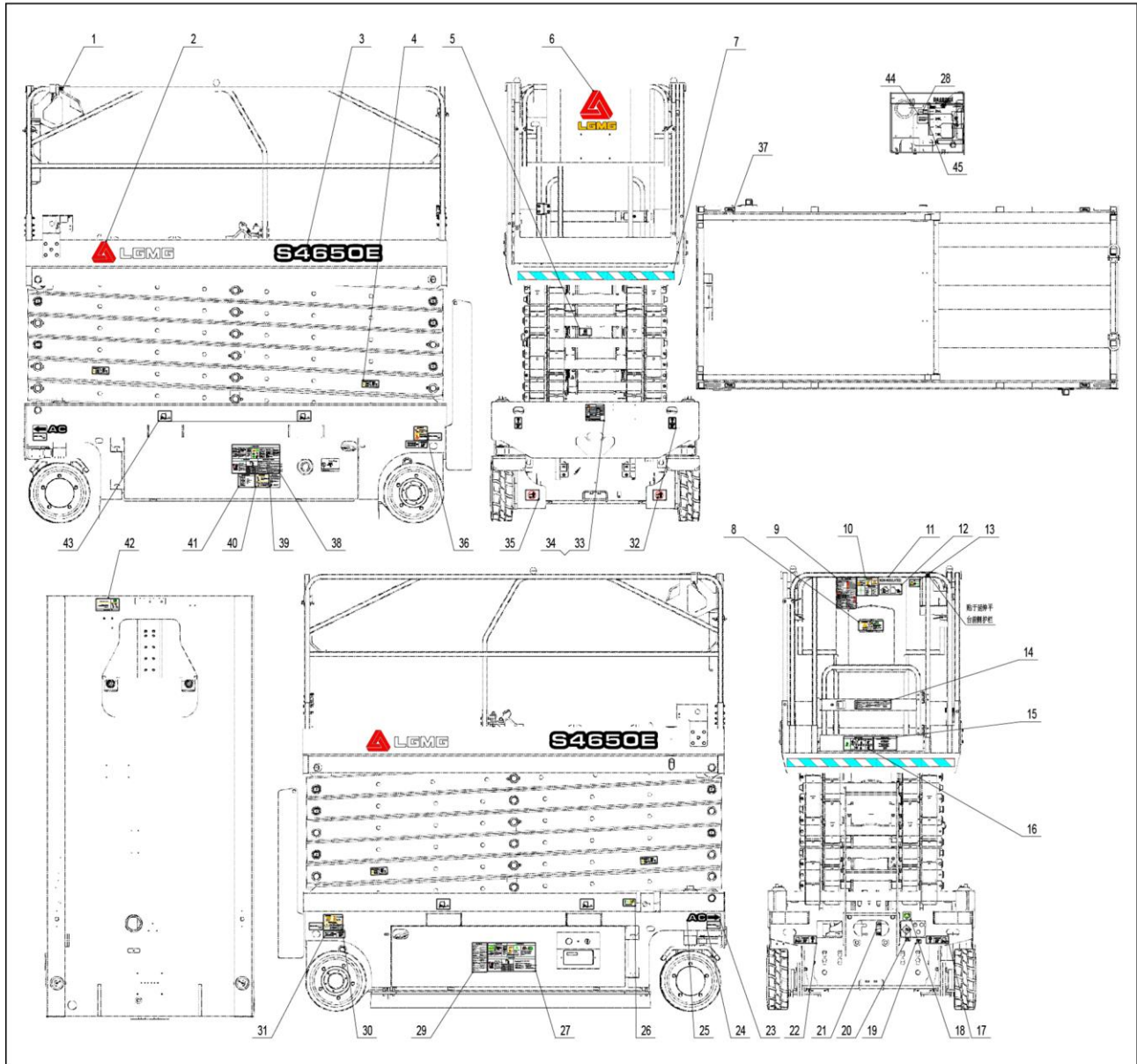











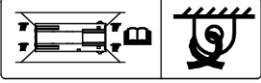
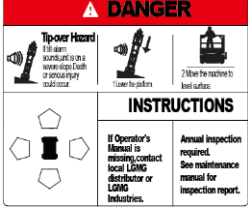
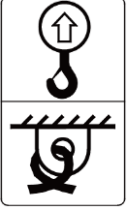

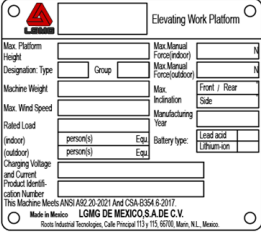
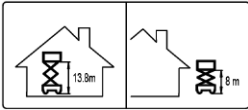
Operation Manual of Scissors Mobile Elevating Work Platform

Name	Decal	Name	Decal
1. Decal-Suspension position		23. Decal-Travel direction	
2. Decal-LOGO-High 130		24. Decal-Wheel load decal	
3. Decal-Model S4650E		25. Decal-Alternating current decal	
4. Decal-Stay away from machine warning		26. Decal-Emergency descent decal	
5. Decal-Fork safety arm decal		27. Decal-Fuel tank side decal	
6. Decal-LOGO-High 240		28. Decal-Oil level decal	
7. Warning wire		29. Decal-Precautions	
8. Decal-Manual		30. Decal-Brake release safety warning	

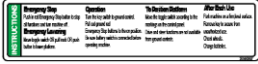

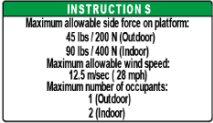







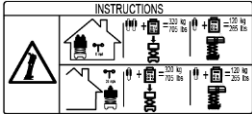
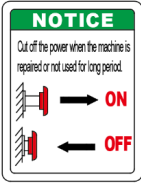

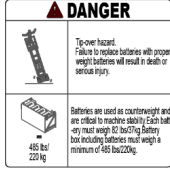
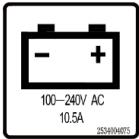
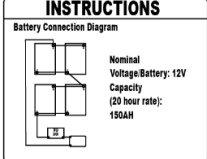
Operation Manual of Scissors Mobile Elevating Work Platform

<p>9. Decal-Safety rules</p>		<p>31. Decal-Transport</p>	
<p>10. Decal-FR column decal</p>		<p>32. Decal-Lifting decal</p>	
<p>11. Decal-Non-insulating decal</p>		<p>33. Complete machine nameplate (Mexico)</p>	
<p>12. Decal-Toggle alert</p>		<p>35. Decal-No water spraying decal</p>	
<p>13. Decal-Slope low speed warning</p>		<p>36. Decal-ELEC shock fire warning</p>	
<p>14. Decal-Operating instructions</p>		<p>37. Decal-Lanyard anchorage point</p>	
<p>15. Decal-Max. manual force decal</p>		<p>38. Decal-Battery side decal</p>	

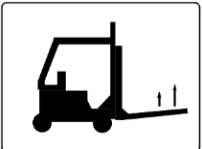

Operation Manual of Scissors Mobile Elevating Work Platform

<p>16. Decal-Platform security warning</p>		<p>39. Decal-Turn off the power</p>	
<p>17. Decal-Telehandler (RH)</p>		<p>40. Decal-Battery as counterweight warning</p>	
<p>18. Decal-Battery charging decal (10.5A)</p>		<p>41. Decal-Battery connection decal</p>	
<p>19. Decal-Unbraking indication</p>		<p>42. Decal-Risk of tipping</p>	
<p>20. Decal-Charging harness decal</p>		<p>43. Decal-Telehandler</p>	
<p>21. Decal-Platform power cable decal</p>		<p>44. Decal-HV32 hyd oil decal</p>	
<p>22. Decal-Telehandler (LH)</p>		<p>45. Decal-No mixing of hyd oil (English)</p>	<p>It's not recommended to mix hydraulic oil of different types, grades and/or brand.</p>



S4650 II Decals

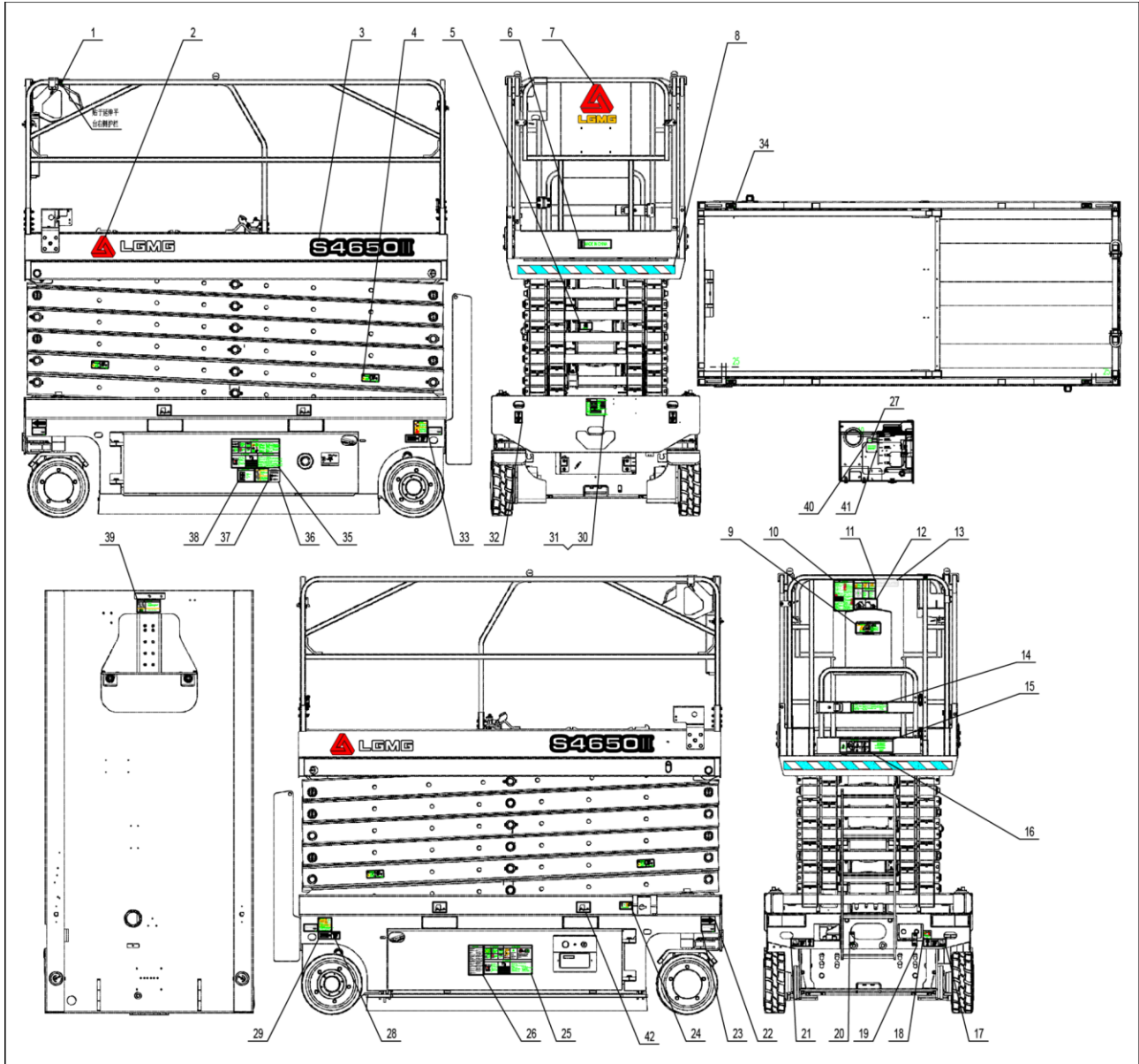









Operation Manual of Scissors Mobile Elevating Work Platform

Name	Decal	Name	Decal
1. Decal-Suspension position		22. Decal-Travel direction	
2. Decal-LOGO-High 130		23. Decal-Wheel load decal	
3. Decal-Model S4650 II		24. Decal-Emergency descent decal	
4. Decal-Stay away from machine warning		25. Decal-Fuel tank side decal	
5. Decal-Fork safety arm decal		26. Decal-Precautions	
6. Decal-Country of origin decal		27. Decal-Oil level decal	
7. Decal-LOGO-High 240		28. Decal-Brake release safety warning	
8. Warning wire		29. Decal-Transport	

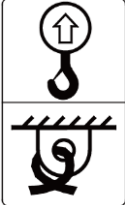
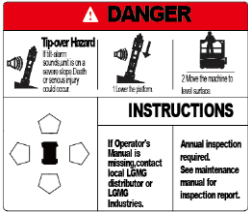

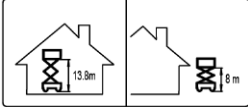

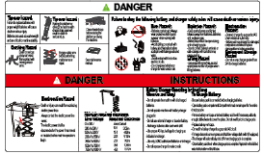
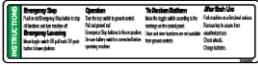
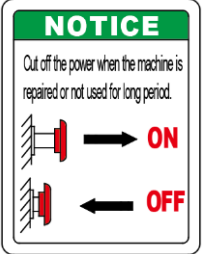
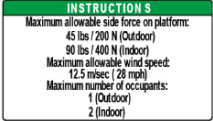
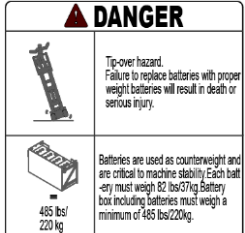



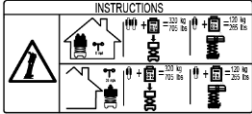
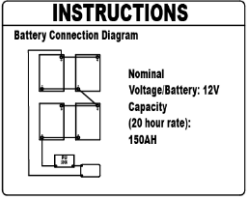

Operation Manual of Scissors Mobile Elevating Work Platform

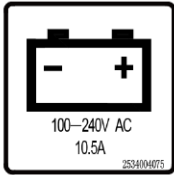
<p>9. Decal-Manual</p>		<p>30. Complete machine nameplate (ANSI)</p>	
<p>10. Decal-Safety rules</p>		<p>32. Decal-Lifting decal</p>	
<p>11. Decal-FR column decal</p>		<p>33. Decal-ELEC shock fire warning</p>	
<p>12. Decal-Toggle alert</p>		<p>34. Decal-Lanyard anchorage point</p>	
<p>13. Decal-Non-insulating decal</p>		<p>35. Decal-Battery side decal</p>	
<p>14. Decal-Operating instructions</p>		<p>36. Decal-Turn off the power</p>	
<p>15. Decal-Max. manual force decal</p>		<p>37. Decal-Battery as counterweight warning</p>	

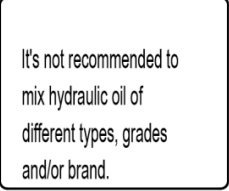

Operation Manual of Scissors Mobile Elevating Work Platform

<p>16. Decal-Platform security warning</p>		<p>38. Decal-Battery connection decal</p>	
<p>17. Decal-Telehandler (RH)</p>		<p>39. Decal-Risk of tipping</p>	
<p>18. Decal-Battery charging decal (10.5A)</p>		<p>40. Decal-HV32 hyd oil decal</p>	
<p>19. Decal-Platform power cable decal</p>		<p>41. Decal-No mixing of hyd oil (English)</p>	
<p>20. Decal-Charging harness decal</p>		<p>42. Decal-Telehandler</p>	
<p>21. Decal-Telehandler (LH)</p>			





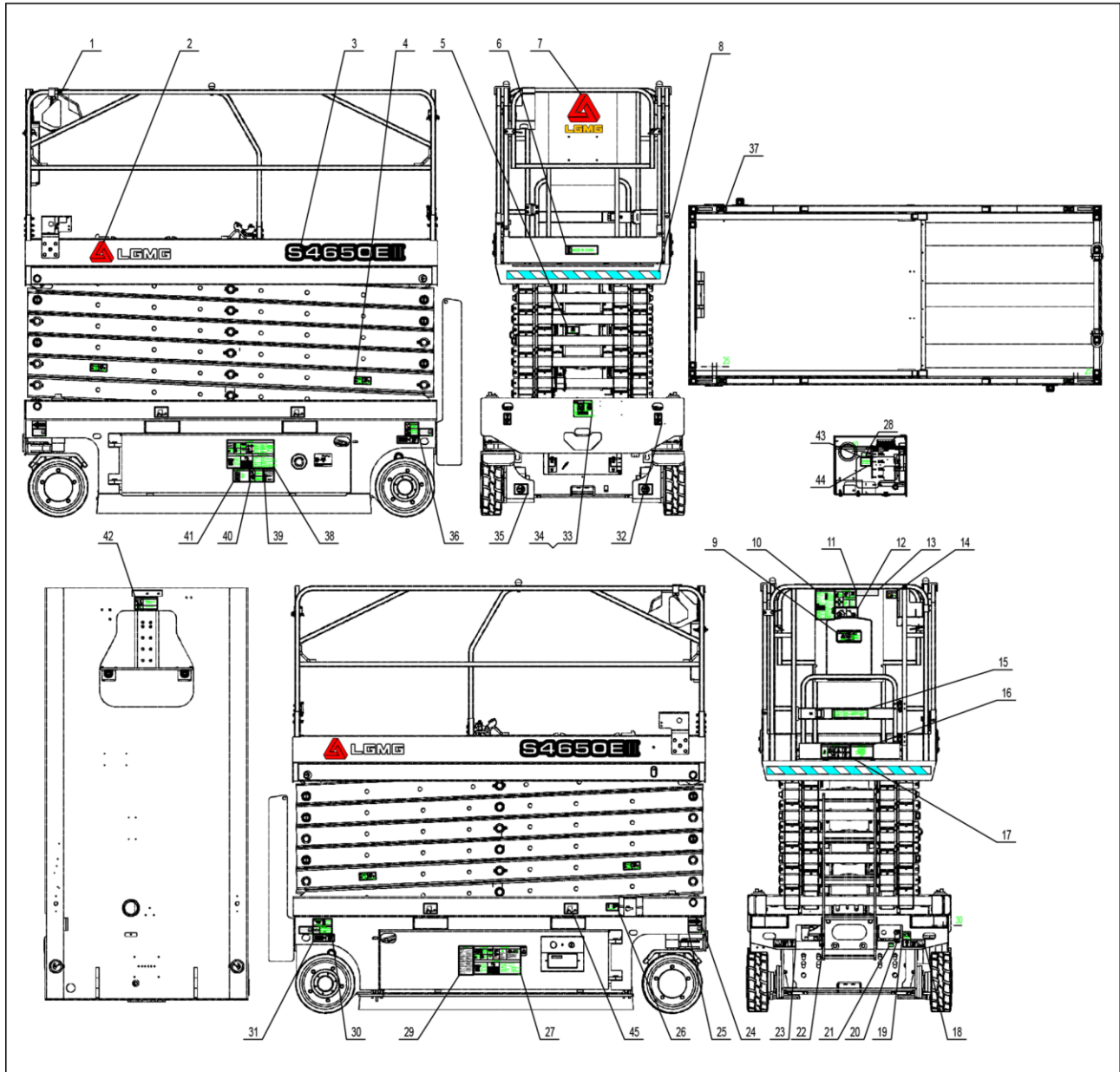







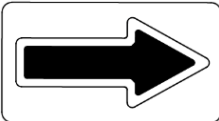

S4650E II Decals

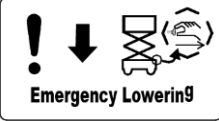











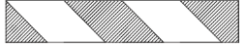

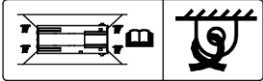

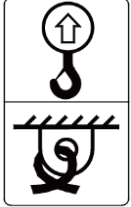
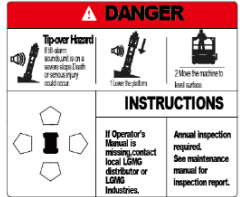
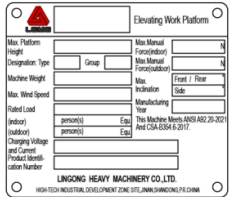
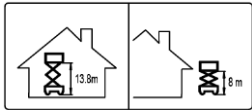
Operation Manual of Scissors Mobile Elevating Work Platform

Name	Decal	Name	Decal
1. Decal-Suspension position		23. Decal-Telehandler (LH)	
2. Decal-LOGO-High 130		24. Decal-Travel direction	
3. Decal-Model S4650E II		25. Decal-Wheel load decal	
4. Decal-Stay away from machine warning		26. Decal-Emergency descent decal	
5. Decal-Fork safety arm decal		27. Decal-Fuel tank side decal	
6. Decal-Country of origin decal		28. Decal-Oil level decal	
7. Decal-LOGO-High 240		29. Decal-Precautions	

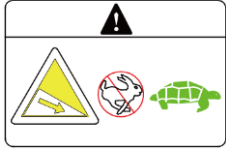

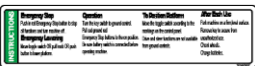





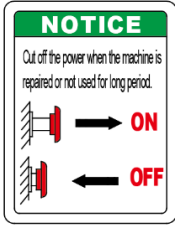
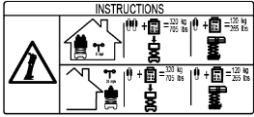
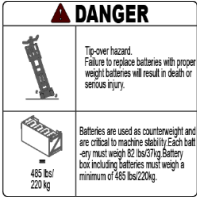

Operation Manual of Scissors Mobile Elevating Work Platform

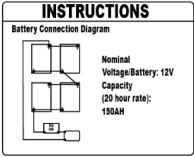
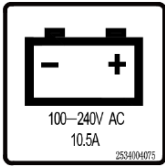
<p>8.Warning wire</p>		<p>30.Decal-Brake release safety warning</p>	
<p>9.Decal-Manual</p>		<p>31.Decal-Transport</p>	
<p>10.Decal-Safety rules</p>		<p>32.Decal-Lifting decal</p>	
<p>11.Decal-FR column decal</p>		<p>33.Complete machine nameplate (ANSI)</p>	
<p>12.Decal-Toggle alert</p>		<p>35.Decal-No water spraying decal</p>	
<p>13.Decal-Non-insulating decal</p>		<p>36.Decal-ELEC shock fire warning</p>	
<p>14.Decal-Slope low speed warning</p>		<p>37.Decal-Lanyard anchorage point</p>	
<p>15.Decal-Operating instructions</p>		<p>38.Decal-Battery side decal</p>	



Operation Manual of Scissors Mobile Elevating Work Platform

<p>16.Decal-Max. manual force decal</p>		<p>39.Decal-Turn off the power</p>	
<p>17.Decal-Platform security warning</p>		<p>40.Decal-Battery as counterweight warning</p>	
<p>18.Decal-Telehandler (RH)</p>		<p>41.Decal-Battery connection decal</p>	
<p>19.Decal-Battery charging decal (10.5A)</p>		<p>42.Decal-Risk of tipping</p>	
<p>20.Decal-Platform power cable decal</p>		<p>43.Decal-HV32 hyd oil decal</p>	
<p>21.Decal-Unbraking indication</p>		<p>44.Decal-No mixing of hyd oil (English)</p>	<p>It's not recommended to mix hydraulic oil of different types, grades and/or brand.</p>
<p>22.Decal-Charging harness decal</p>		<p>45.Decal-Telehandler</p>	



Chapter 10 Specifications

S1932E (S193202WDQ0AE1020/S193202WDQ0AE1M00) Operating Specifications

The performance parameters of the whole machine

Items	Parameters	Items	Parameters	
Rated load (kg/lbs)	230/510	Fork lifting time (s)	16±2	
Extended platform load (kg/lbs)	120/265	Fork descending time (s)	28±3	
Weight of the whole machine (kg/lbs)	1610/3549	The maximum manual force	Indoor (N)	400
The maximum number of workers (indoor)	2		Outdoor (N)	200
The maximum number of workers (outdoor)	1	Theoretical maximum climbing ability (unloaded and with fork arms retracted)		25%
The maximum working height (m/ft)	7.8/25.6	The maximum allowable tilt angle	X direction: Left/right direction	1.5°
The maximum platform height (m/ft)	5.8/19		Y direction: Front/rear direction	3°
The minimum turning radius (m/ft)	1.8/5.9	The maximum inner wheel angle	70°	
The maximum travelling speed (with fork arms retracted) (km/h/mpH)	3.5±0.2/ 2.2±0.12	The maximum allowable wind speed (m/s/mpH)	12.5/28	
The maximum travelling speed (lifting) (km/h/mpH)	0.8±0.1/ 0.5±0.06	Driving type	Front wheel drive Front wheel steering	
The maximum braking distance (unloaded and with fork arms retracted) (mm/in)	600/23.6			

Main dimensions

Items	Parameters	Items	Parameters
Overall length (with ladder installed) (mm/in)	1829/72	Extension size of the platform (mm/in)	900/35.4
Overall length (without ladder) (mm/in)	1679/66.1	Wheelbase (mm/in)	1345/52.9
Machine width (mm/in)	790/31.1	Tread (mm/in)	700/27.5
Height of the whole machine (with guardrail not retracted) (mm/in)	2155/84.8	The minimum ground clearance (with fork arms retracted) (mm/in)	77/3.03
Height of the whole machine (with guardrail retracted) (mm/in)	1810/71.2	The minimum ground clearance (lifting) (mm/in)	26/1
Dimensions of the working bench (length × width) (mm/in)	1635×730/ 64.3×28.7	Tire size (diameter × width) (mm/in)	Φ323×100/ 12.7×3.9



Transmission system

Items		Parameters/Content
Travelling reducer	Rated output torque (Nm)	500

Hydraulic system

Items		Parameters/Content
Functional system	Type	Open system
	Pump displacement (ml/r)	3.2
	Lifting system	The maximum working pressure (MPa/psi) 20.5/2973
	Steering system	The maximum working pressure (MPa/psi) 12/1740

Electrical system

Items		Parameters/Content
Driving motor	Rated power (kW)	0.7
Lifting motor	Rated power (kW)	3.42
Battery	Output voltage (V)	6
	Capacity (Ah)	225(20 hours discharge rate)
Charger	Nominal AC input voltage (V)	100-240V AC
	The maximum AC input current (A)	10.5
	Nominal DC output voltage (V)	24
	The maximum DC output current (A)	30
Control system	Voltage (V)	24

Oil filling amount

Items	Parameters/Content	Items	Parameters/Content
Hydraulic oil (L)	5	Gear oil for travelling reducer (L)	0.3

Floor loading information

Items	Parameters/Content	Items	Parameters/Content
Tire contact pressure (kPa)	1220	Occupied floor pressure (kPa)	11.9

Tire specification

Items	Parameters/Content	Items	Parameters/Content
Drive wheel load-6km/h (kg)	955	Maximum static load (kg)	1345



S1932 II (S193202WDQ0AH1010) Operating Specifications

The performance parameters of the whole machine

Items	Parameters	Items	Parameters
Rated load (kg)	230	Fork lifting time (s)	16±2
Extended platform load (kg)	120	Fork descending time (s)	28±3
Weight of the whole machine (kg)	1610	The maximum manual force	Indoor (N) 400
The maximum number of workers (indoor)	2		Outdoor (N) 200
The maximum number of workers (outdoor)	1	Theoretical maximum climbing ability (unloaded and with fork arms retracted) 25%	
The maximum working height (m)	7.8	The maximum allowable tilt angle	X direction: Left/right direction 1.5°
The maximum platform height (m)	5.8		Y direction: Front/rear direction 3°
The minimum turning radius (m)	1.7	The maximum inner wheel angle	70°
The maximum travelling speed (with fork arms retracted) (km/h)	3±0.5	The maximum allowable wind speed (m/s)	12.5
The maximum travelling speed (lifting) (km/h)	0.8±0.1	Driving type	Front wheel drive Front wheel steering
The maximum braking distance (unloaded and with fork arms retracted) (mm)	600		

Main dimensions

Items	Parameters	Items	Parameters
Overall length (with ladder installed) (mm)	1829	Extension size of the platform (mm)	900
Overall length (without ladder) (mm)	1679	Wheelbase (mm)	1350
Machine width (mm)	790	Tread (mm)	700
Height of the whole machine (with guardrail not retracted) (mm)	2155	The minimum ground clearance (with fork arms retracted) (mm)	77
Height of the whole machine (with guardrail retracted) (mm)	1810	The minimum ground clearance (lifting) (mm)	26
Dimensions of the working bench (length × width) (mm)	1635×730	Tire size (diameter x width) (mm)	Φ323×100

Hydraulic system

Items	Parameters/Content
Functional Type	Open system



Operation Manual of Scissors Mobile Elevating Work Platform

system	Pump displacement (ml/r)		4
	Driving system	The maximum working pressure (MPa)	25
	Lifting system	The maximum working pressure (MPa)	19
	Steering system	The maximum working pressure (MPa)	12

Electrical system

Items		Parameters/Content
Lifting motor	Rated power (kW)	3.3
Battery	Output voltage (V)	6
	Capacity (Ah)	225
Charger	Nominal AC input voltage (V)	100-240VAC
	The maximum AC input current (A)	10.5
	Nominal DC output voltage (V)	24
	The maximum DC output current (A)	30
Control system	Voltage (V)	24

Oil filling amount

Items	Parameters/Content	Items	Parameters/Content
Hydraulic oil (L)	9.5	—	—

Floor loading information

Items	Parameters/Content	Items	Parameters/Content
Tire contact pressure (kPa)	1220	Occupied floor pressure (kPa)	11.9

Tire specification

Items	Parameters/Content	Items	Parameters/Content
Drive wheel load-6km/h (kg)	955	Maximum static load (kg)	1345



S1932E II (S193202WDQ0AE1010) Operating Specifications

The performance parameters of the whole machine

Items	Parameters	Items	Parameters
Rated load (kg)	230	Fork lifting time (s)	16±3
Extended platform load (kg)	120	Fork descending time (s)	28±3
Weight of the whole machine (kg)	1610	The maximum manual force	Indoor (N) 400
The maximum number of workers (indoor)	2		Outdoor (N) 200
The maximum number of workers (outdoor)	1	Theoretical maximum climbing ability (unloaded and with fork arms retracted) 25%	
The maximum working height (m)	7.8	The maximum allowable tilt angle	X direction: Left/right direction 1.5°
The maximum platform height (m)	5.8		Y direction: Front/rear direction 3°
The minimum turning radius (m)	1.8	The maximum inner wheel angle	70°
The maximum travelling speed (with fork arms retracted) (km/h)	3.5±0.5	The maximum allowable wind speed (m/s)	12.5
The maximum travelling speed (lifting) (km/h)	0.8±0.1	Driving type	Front wheel drive Front wheel steering
The maximum braking distance (unloaded and with fork arms retracted) (mm)	600		

Main dimensions

Items	Parameters	Items	Parameters
Overall length (with ladder installed) (mm)	1827	Extension size of the platform (mm)	900
Overall length (without ladder) (mm)	1679	Wheelbase (mm)	1345
Machine width (mm)	790	Tread (mm)	700
Height of the whole machine (with guardrail not retracted) (mm)	2155	The minimum ground clearance (with fork arms retracted) (mm)	77
Height of the whole machine (with guardrail retracted) (mm)	1810	The minimum ground clearance (lifting) (mm)	26
Dimensions of the working bench (length × width) (mm)	1635×730	Tire size (diameter x width) (mm)	Φ323×100

Transmission system

Items	Parameters/Content
Travelling reducer	Rated output torque (Nm) 500



Hydraulic system

Items		Parameters/Content
Functional system	Type	Open system
	Pump displacement (ml/r)	3.1
	Lifting system	The maximum working pressure (MPa) 19
	Steering system	The maximum working pressure (MPa) 12

Electrical system

Items		Parameters/Content
Driving motor	Rated power (kW)	0.81
Lifting motor	Rated power (kW)	2.4
Battery	Output voltage (V)	6
	Capacity (Ah)	225(20 hours discharge rate)
Charger	Nominal AC input voltage (V)	100-240VAC
	The maximum AC input current (A)	10.5
	Nominal DC output voltage (V)	24
	The maximum DC output current (A)	30
Control system	Voltage (V)	24

Oil filling amount

Items	Parameters/Content	Items	Parameters/Content
Hydraulic oil (L)	13	Gear oil for travelling reducer (L)	0.3

Floor loading information

Items	Parameters/Content	Items	Parameters/Content
Tire contact pressure (kPa)	1220	Occupied floor pressure (kPa)	11.9

Tire specification

Items	Parameters/Content	Items	Parameters/Content
Drive wheel load-6km/h (kg)	955	Maximum static load (kg)	1345



S2632E (S263202WDQ0AE1020) Operating Specifications

The performance parameters of the whole machine

Items	Parameters	Items	Parameters
Rated load (kg)	230	Fork lifting time (s)	31±3
Extended platform load (kg)	120	Fork descending time (s)	40±3
Weight of the whole machine (kg)	2200	The maximum manual force	Indoor (N)
The maximum number of workers (indoor)	2		Outdoor (N)
The maximum number of workers (outdoor)	1	Theoretical maximum climbing ability (unloaded and with fork arms retracted)	25%
The maximum working height (m)	9.8 (in) 8 (out)	The maximum allowable tilt angle	X direction: Left/right direction
The maximum platform height (m)	7.8 (in) 6 (out)		Y direction: Front/rear direction
The minimum turning radius (m)	2.2	The maximum inner wheel angle	75°
The maximum travelling speed (with fork arms retracted) (km/h)	3.5±0.5	The maximum allowable wind speed (m/s)	12.5
The maximum travelling speed (lifting) (km/h)	0.8±0.1	Driving type	Front wheel drive Front wheel steering
The maximum braking distance (unloaded and with fork arms retracted) (mm)	600		

Main dimensions

Items	Parameters	Items	Parameters
Overall length (with ladder installed) (mm)	2440	Extension size of the platform (mm)	900
Overall length (without ladder) (mm)	2270	Wheelbase (mm)	1850
Machine width (mm)	830	Tread (mm)	700
Height of the whole machine (with guardrail not retracted) (mm)	2280	The minimum ground clearance (with fork arms retracted) (mm)	100
Height of the whole machine (with guardrail retracted) (mm)	1900	The minimum ground clearance (lifting) (mm)	20
Dimensions of the working bench (length × width) (mm)	2260×790	Tire size (diameter × width) (mm)	Φ380×130



Hydraulic system

Items		Parameters/Content	
Functional system	Type		Open system
	Pump displacement (ml/r)		4
	Lifting system	The maximum working pressure (MPa)	21
	Steering system	The maximum working pressure (MPa)	15

Electrical system

Items		Parameters/Content
Drive motor	Rated power (kW)	0.7
Lifting motor	Rated power (kW)	3.42
Battery	Output voltage (V)	6
	Capacity (Ah)	225(20 hours discharge rate)
Charger	Nominal AC input voltage (V)	100-240VAC
	The maximum AC input current (A)	10.5
	Nominal DC output voltage (V)	24
	The maximum DC output current (A)	30
Control system	Voltage (V)	24

Oil filling amount

Items	Parameters/Content	Items	Parameters/Content
Hydraulic oil (L)	13	Walking gear reducer gear grease (L)	0.3

Floor loading information

Items	Parameters/Content	Items	Parameters/Content
Tire contact pressure (kPa)	1240	Occupied floor pressure (kPa)	11.4

Tire specification

Items	Parameters/Content	Items	Parameters/Content
Drive wheel load-6km/h (kg)	1395	Maximum static load (kg)	1630



S2632 II (S263202WDQ0AH1010) Operating Specifications

The performance parameters of the whole machine

Items	Parameters	Items	Parameters	
Rated load (kg)	230	Fork lifting time (s)	31±3	
Extended platform load (kg)	120	Fork descending time (s)	40±3	
Weight of the whole machine (kg)	2200	The maximum manual force	Indoor (N)	400
The maximum number of workers (indoor)	2		Outdoor (N)	200
The maximum number of workers (outdoor)	1	Theoretical maximum climbing ability (unloaded and with fork arms retracted)		25%
The maximum working height (m)	9.8 (in)	The maximum allowable tilt angle	X direction: Left/right direction	1.5°
	8 (out)		Y direction: Front/rear direction	
The maximum platform height (m)	7.8 (in)	The maximum inner wheel angle		75°
	6 (out)			
The minimum turning radius (m)	2.2	The maximum allowable wind speed (m/s)		12.5
The maximum travelling speed (with fork arms retracted) (km/h)	3±0.5	Driving type		Front wheel drive Front wheel steering
The maximum travelling speed (lifting) (km/h)	0.8±0.1			
The maximum braking distance (unloaded and with fork arms retracted) (mm)	600			

Main dimensions

Items	Parameters	Items	Parameters
Overall length (with ladder installed) (mm)	2440	Extension size of the platform (mm)	900
Overall length (without ladder) (mm)	2270	Wheelbase (mm)	1850
Machine width (mm)	830	Tread (mm)	700
Height of the whole machine (with guardrail not retracted) (mm)	2280	The minimum ground clearance (with fork arms retracted) (mm)	100
Height of the whole machine (with guardrail retracted) (mm)	1900	The minimum ground clearance (lifting) (mm)	25
Dimensions of the working bench (length × width) (mm)	2260×790	Tire size (diameter × width) (mm)	Φ380×130



Hydraulic system

Items		Parameters/Content
Functional system	Type	Open system
	Pump displacement (ml/r)	4
	Driving system	The maximum working pressure (MPa)
	Lifting system	The maximum working pressure (MPa)
	Steering system	The maximum working pressure (MPa)
Braking system	The maximum working pressure (MPa)	25

Electrical system

Items		Parameters/Content
Lifting motor	Rated power (kW)	3.3
Battery	Output voltage (V)	6
	Capacity (Ah)	225(20 hours discharge rate)
Charger	Nominal AC input voltage (V)	100-240VAC
	The maximum AC input current (A)	10.5
	Nominal DC output voltage (V)	24
	The maximum DC output current (A)	30
Control system	Voltage (V)	24

Oil filling amount

Items	Parameters/Content	Items	Parameters/Content
Hydraulic oil (L)	13		

Floor loading information

Items	Parameters/Content	Items	Parameters/Content
Tire contact pressure (kPa)	1240	Occupied floor pressure (kPa)	11.4

Tire specification

Items	Parameters/Content	Items	Parameters/Content
Drive wheel load-6km/h (kg)	1395	Maximum static load (kg)	1630



S2632E II (S263202WDQ0AE1010) Operating Specifications

The performance parameters of the whole machine

Items	Parameters	Items	Parameters
Rated load (kg)	230	Fork lifting time (s)	31±3
Extended platform load (kg)	120	Fork descending time (s)	40±3
Weight of the whole machine (kg)	2200	The maximum manual force	Indoor (N)
The maximum number of workers (indoor)	2		Outdoor (N)
The maximum number of workers (outdoor)	1	Theoretical maximum climbing ability (unloaded and with fork arms retracted)	25%
The maximum working height (m)	9.8 (in) 8 (out)	The maximum allowable tilt angle	X direction: Left/right direction
The maximum platform height (m)	7.8 (in) 6 (out)		Y direction: Front/rear direction
The minimum turning radius (m)	2.2	The maximum inner wheel angle	75°
The maximum travelling speed (with fork arms retracted) (km/h)	3.5±0.5	The maximum allowable wind speed (m/s)	12.5
The maximum travelling speed (lifting) (km/h)	0.8±0.1	Driving type	Front wheel drive Front wheel steering
The maximum braking distance (unloaded and with fork arms retracted) (mm)	600		

Main dimensions

Items	Parameters	Items	Parameters
Overall length (with ladder installed) (mm)	2440	Extension size of the platform (mm)	900
Overall length (without ladder) (mm)	2270	Wheelbase (mm)	1850
Machine width (mm)	830	Tread (mm)	700
Height of the whole machine (with guardrail not retracted) (mm)	2280	The minimum ground clearance (with fork arms retracted) (mm)	100
Height of the whole machine (with guardrail retracted) (mm)	1900	The minimum ground clearance (lifting) (mm)	20
Dimensions of the working bench (length × width) (mm)	2260×790	Tire size (diameter × width) (mm)	Φ380×130



Hydraulic system

Items		Parameters/Content	
Functional system	Type		Open system
	Pump displacement (ml/r)		4
	Lifting system	The maximum working pressure (MPa)	21
	Steering system	The maximum working pressure (MPa)	15

Electrical system

Items		Parameters/Content
Drive motor	Rated power (kW)	0.81
Lifting motor	Rated power (kW)	3.3
Battery	Output voltage (V)	6
	Capacity (Ah)	225(20 hours discharge rate)
Charger	Nominal AC input voltage (V)	100-240VAC
	The maximum AC input current (A)	10.5
	Nominal DC output voltage (V)	24
	The maximum DC output current (A)	30
Control system	Voltage (V)	24

Oil filling amount

Items	Parameters/Content	Items	Parameters/Content
Hydraulic oil (L)	13	Walking gear reducer gear grease (L)	0.3

Floor loading information

Items	Parameters/Content	Items	Parameters/Content
Tire contact pressure (kPa)	1240	Occupied floor pressure (kPa)	11.4

Tire specification

Items	Parameters/Content	Items	Parameters/Content
Drive wheel load-6km/h (kg)	1395	Maximum static load (kg)	1630



SS2632E (S263200WDQ0AE1M00) Operating Specifications

The performance parameters of the whole machine

Items	Parameters	Items	Parameters	
Rated load (kg/lbs)	227/500	Fork lifting time (s)	31±3	
Extended platform load (kg/ lbs)	113/250	Fork descending time (s)	27±3	
Weight of the whole machine (kg/lbs)	1980/4365	The maximum manual force	Indoor (N) (without pedal/with pedal)	400/200
The maximum number of workers (indoor)	2		Outdoor (N)	200
The maximum number of workers (outdoor)	1	Theoretical maximum climbing ability (unloaded and with fork arms retracted)		25%
The maximum working height (m/ft)	9.6/31.5 (in) 7.5/24.6 (out)	The maximum allowable tilt angle	X direction: Left/right direction	1.5°
The maximum platform height (m/ft)	7.6/25 (in) 5.5/18 (out)		Y direction: Front/rear direction	3°
The minimum turning radius (m/ft)	1.8/5.9	The maximum inner wheel angle(°)	70°	
The maximum travelling speed (with fork arms retracted) (km/h/mpH)	3.5±0.2/ 2.2±0.12	The maximum allowable wind speed (m/s/mpH)	12.5/28	
The maximum travelling speed (lifting) (km/h/mpH)	0.5±0.1/ 0.3±0.06	Driving type	Front wheel drive Front wheel steering	
The maximum braking distance (unloaded and with fork arms retracted) (mm/in)	600/23.6			

Main dimensions

Items	Parameters	Items	Parameters
Overall length (with ladder installed) (mm/in)	1900/74.8	Extension size of the platform (mm/in)	900/35.4
Overall length (without ladder) (mm/in)	1777/69.9	Wheelbase (mm/in)	1400/15.7
Machine width (mm/in)	810/31.9	Track (mm/in)	710/28
Height of the whole machine (with guardrail not retracted) (mm/in)	2277/89.6	The minimum ground clearance (with fork arms retracted) (mm/in)	72/2.8
Height of the whole machine (with guardrail retracted) (mm/in)	1930/76	The minimum ground clearance (lifting) (mm/in)	20/0.79
Dimensions of the working bench (length × width) (mm/in)	1700×730/ 66.9×28.7	Tire size (diameter x width) (mm/in)	Φ305×100/ 12×4



Drivetrain

Item		Parameter/Content
Traveling reducer	Rated output torque (Nm)	250
	Gear ratio	52.308:1

Hydraulic system

Items			Parameters/Content
Functional system	Type		Open system
	Pump displacement (ml/r)		4.0
	Lifting system	The maximum working pressure (MPa/psi)	21/3046
	Steering system	The maximum working pressure (MPa/psi)	12/1740

Electrical system

Items		Parameters/Content
Drive motor	Rated power (kW)	0.5
Lifting motor	Rated power (kW)	3
Battery	Output voltage (V)	12 (single battery)
	Capacity (Ah)	150(20-hours discharge rate)
Charger	Nominal AC input voltage (V)	100-240V AC
	The maximum AC input current (A)	4.5
	Nominal DC output voltage (V)	24
	The maximum DC output current (A)	15
Control system	Voltage (V)	24

Oil filling amount

Items	Parameters/Content	Items	Parameters/Content
Hydraulic oil (L)	8.5	Walking gear reducer gear grease (L)	0.5

Floor loading information

Items	Parameters/Content	Items	Parameters/Content
Tire contact pressure (kPa)	1155	Occupied floor pressure (kPa)	13.48

Tire specification

Items	Parameters/Content	Items	Parameters/Content
Drive wheel load-6km/h (kg)	935	Maximum static load (kg)	1040



S2646E (S264602WDQ0AE1020) Operating Specifications

The performance parameters of the whole machine

Items	Parameters	Items	Parameters
Rated load (kg)	450	Fork lifting time (s)	35±4
Extended platform load (kg)	120	Fork descending time (s)	40±4
Weight of the whole machine (kg)	2318	The maximum manual force	Indoor (N) 400
The maximum number of workers (indoor)	2		Outdoor (N) 200
The maximum number of workers (outdoor)	1	Theoretical maximum climbing ability (unloaded and with fork arms retracted) 25%	
The maximum working height (m)	10	The maximum allowable tilt angle	X direction: Left/right direction 1.5°
The maximum platform height (m)	8		Y direction: Front/rear direction 3°
The minimum turning radius (m)	2.45	The maximum inner wheel angle	75°
The maximum travelling speed (with fork arms retracted) (km/h)	3.5±0.2	The maximum allowable wind speed (m/s)	12.5
The maximum travelling speed (lifting) (km/h)	0.8±0.1	Driving type	Front wheel drive Front wheel steering
The maximum braking distance (unloaded and with fork arms retracted) (mm)	600		

Main dimensions

Items	Parameters	Items	Parameters
Overall length (with ladder installed) (mm)	2490	Extension size of the platform (mm)	900
Overall length (without ladder) (mm)	2270	Wheelbase (mm)	1850
Machine width (mm)	1180	Tread (mm)	1050
Height of the whole machine (with guardrail not retracted) (mm)	2360	The minimum ground clearance (with fork arms retracted) (mm)	100
Height of the whole machine (with guardrail retracted) (mm)	1550	The minimum ground clearance (lifting) (mm)	20
Dimensions of the working bench (length × width) (mm)	2260×1120	Tire size (diameter x width) (mm)	Φ380×130



Hydraulic system

Items		Parameters/Content
Functional system	Type	Open system
	Pump displacement (ml/r)	4.5
	Lifting system	The maximum working pressure (MPa) 21
	Steering system	The maximum working pressure (MPa) 15

Electrical system

Items		Parameters/Content
Lifting motor	Rated power (kW)	3.42
Battery	Output voltage (V)	6
	Capacity (Ah)	240(20 hours discharge rate)
Charger	Nominal AC input voltage (V)	100-240VAC
	The maximum AC input current (A)	10.5
	Nominal DC output voltage (V)	24
	The maximum DC output current (A)	30
Control system	Voltage (V)	24

Oil filling amount

Items	Parameters/Content	Items	Parameters/Content
Hydraulic oil (L)	16	Gear oil for travelling reducer (L)	0.3

Floor loading information

Items	Parameters/Content	Items	Parameters/Content
Tire contact pressure (kPa)	931.87	Occupied floor pressure (kPa)	11.71

Tire specification

Items	Parameters/Content	Items	Parameters/Content
Drive wheel load-6km/h (kg)	1395	Maximum static load (kg)	1630



S2646 II (S264602WDQ0AH1010) Operating Specifications

The performance parameters of the whole machine

Items	Parameters	Items	Parameters
Rated load (kg)	450	Fork lifting time (s)	35±3
Extended platform load (kg)	120	Fork descending time (s)	40±3
Weight of the whole machine (kg)	2395	The maximum manual force	Indoor (N)
The maximum number of workers (indoor)	2		Outdoor (N)
The maximum number of workers (outdoor)	1	Theoretical maximum climbing ability (unloaded and with fork arms retracted)	
The maximum working height (m)	10	The maximum allowable tilt angle	X direction: Left/right direction
The maximum platform height (m)	8		Y direction: Front/rear direction
The minimum turning radius (m)	2.45	The maximum inner wheel angle	75°
The maximum travelling speed (with fork arms retracted) (km/h)	3.0±0.5	The maximum allowable wind speed (m/s)	12.5
The maximum travelling speed (lifting) (km/h)	0.8±0.1	Driving type	Front wheel drive Front wheel steering
The maximum braking distance (unloaded and with fork arms retracted) (mm)	600		

Main dimensions

Items	Parameters	Items	Parameters
Overall length (with ladder installed) (mm)	2490	Extension size of the platform (mm)	900
Overall length (without ladder) (mm)	2270	Wheelbase (mm)	1850
Machine width (mm)	1180	Tread (mm)	1050
Height of the whole machine (with guardrail not retracted) (mm)	2360	The minimum ground clearance (with fork arms retracted) (mm)	100
Height of the whole machine (with guardrail retracted) (mm)	1550	The minimum ground clearance (lifting) (mm)	20
Dimensions of the working bench (length × width) (mm)	2260×1120	Tire size (diameter x width) (mm)	Φ380×130

Hydraulic system

Items	Parameters/Content
Functional Type	Open system



Operation Manual of Scissors Mobile Elevating Work Platform

system	Pump displacement (ml/r)		4.5
	Walking system	The maximum working pressure (MPa)	25
	Lifting system	The maximum working pressure (MPa)	21
	Steering system	The maximum working pressure (MPa)	15
	braking system	The maximum working pressure (MPa)	25

Electrical system

Items		Parameters/Content
Lifting motor	Rated power (kW)	4.5
Battery	Output voltage (V)	6
	Capacity (Ah)	240(20 hours discharge rate)
Charger	Nominal AC input voltage (V)	100-240VAC
	The maximum AC input current (A)	10.5
	Nominal DC output voltage (V)	24
	The maximum DC output current (A)	30
Control system	Voltage (V)	24

Oil filling amount

Items	Parameters/Content	Items	Parameters/Content
Hydraulic oil (L)	16	—	—

Floor loading information

Items	Parameters/Content	Items	Parameters/Content
Tire contact pressure (kPa)	1240	Occupied floor pressure (kPa)	11.4

Tire specification

Items	Parameters/Content	Items	Parameters/Content
Drive wheel load-6km/h (kg)	1395	Maximum static load (kg)	1630



S2646E II (S264602WDQ0AE1010) Operating Specifications

The performance parameters of the whole machine

Items	Parameters	Items	Parameters
Rated load (kg)	450	Fork lifting time (s)	35±3
Extended platform load (kg)	120	Fork descending time (s)	40±3
Weight of the whole machine (kg)	2318	The maximum manual force	Indoor (N) 400
The maximum number of workers (indoor)	2		Outdoor (N) 200
The maximum number of workers (outdoor)	1	Theoretical maximum climbing ability (unloaded and with fork arms retracted)	
The maximum working height (m)	10	The maximum allowable tilt angle	X direction: Left/right direction
			Y direction: Front/rear direction
The maximum platform height (m)	8		
The minimum turning radius (m)	2.45	The maximum inner wheel angle	75°
The maximum travelling speed (with fork arms retracted) (km/h)	3.5±0.2	The maximum allowable wind speed (m/s)	12.5
The maximum travelling speed (lifting) (km/h)	0.8±0.1	Driving type	Front wheel drive Front wheel steering
The maximum braking distance (unloaded and with fork arms retracted) (mm)	600		

Main dimensions

Items	Parameters	Items	Parameters
Overall length (with ladder installed) (mm)	2490	Extension size of the platform (mm)	900
Overall length (without ladder) (mm)	2270	Wheelbase (mm)	1850
Machine width (mm)	1180	Tread (mm)	1050
Height of the whole machine (with guardrail not retracted) (mm)	2360	The minimum ground clearance (with fork arms retracted) (mm)	100
Height of the whole machine (with guardrail retracted) (mm)	1550	The minimum ground clearance (lifting) (mm)	20
Dimensions of the working bench (length × width) (mm)	2260×1120	Tire size (diameter x width) (mm)	Φ380×130

Hydraulic system

Items	Parameters/Content
Functional Type	Open system



Operation Manual of Scissors Mobile Elevating Work Platform

system	Pump displacement (ml/r)		4.5
	Lifting system	The maximum working pressure (MPa)	21
	Steering system	The maximum working pressure (MPa)	15

Electrical system

Items		Parameters/Content
Driving motor	Rated power (kW)	0.81
Lifting motor	Rated power (kW)	4.5
Battery	Output voltage (V)	6
	Capacity (Ah)	240(20 hours discharge rate)
Charger	Nominal AC input voltage (V)	100-240VAC
	The maximum AC input current (A)	10.5
	Nominal DC output voltage (V)	24
	The maximum DC output current (A)	30
Control system	Voltage (V)	24

Oil filling amount

Items	Parameters/Content	Items	Parameters/Content
Hydraulic oil (L)	16	Gear oil for travelling reducer (L)	0.3

Floor loading information

Items	Parameters/Content	Items	Parameters/Content
Tire contact pressure (kPa)	1240	Occupied floor pressure (kPa)	11.4

Tire specification

Items	Parameters/Content	Items	Parameters/Content
Drive wheel load-6km/h (kg)	1395	Maximum static load (kg)	1630



S3246E (S324602WDQ0AE1020) Operating Specifications

The performance parameters of the whole machine

Items	Parameters	Items	Parameters
Rated load (kg)	320	Fork lifting time (s)	58±4
Extended platform load (kg)	120	Fork descending time (s)	48±4
Weight of the whole machine (kg)	2995	The maximum manual force	Indoor (N) 400
The maximum number of workers (indoor)	2		Outdoor (N) 200
The maximum number of workers (outdoor)	1	Theoretical maximum climbing ability (unloaded and with fork arms retracted) 25%	
The maximum working height (m)	12	The maximum allowable tilt angle	X direction: Left/right direction 1.5°
The maximum platform height (m)	10		Y direction: Front/rear direction 3°
The minimum turning radius (m)	2.45	The maximum inner wheel angle	75°
The maximum travelling speed (with fork arms retracted) (km/h)	3.5±0.2	The maximum allowable wind speed (m/s)	12.5
The maximum travelling speed (lifting) (km/h)	0.8±0.1	Driving type	Front wheel drive Front wheel steering
The maximum braking distance (unloaded and with fork arms retracted) (mm)	600		

Main dimensions

Items	Parameters	Items	Parameters
Overall length (with ladder installed) (mm)	2490	Extension size of the platform (mm)	900
Overall length (without ladder) (mm)	2270	Wheelbase (mm)	1850
Machine width (mm)	1180	Tread (mm)	1050
Height of the whole machine (with guardrail not retracted) (mm)	2490	The minimum ground clearance (with fork arms retracted) (mm)	100
Height of the whole machine (with guardrail retracted) (mm)	1675	The minimum ground clearance (lifting) (mm)	20
Dimensions of the working bench (length × width) (mm)	2260×1120	Tire size (diameter x width) (mm)	Φ380×130

Transmission system

Items	Parameters/Content
Travelling reducer	Rated output torque (Nm) 500



Hydraulic system

Items		Parameters/Content
Functional system	Type	Open system
	Pump displacement (ml/r)	4.5
	Lifting system	The maximum working pressure (MPa) 21
	Steering system	The maximum working pressure (MPa) 15

Electrical system

Items		Parameters/Content
Driving motor	Rated power (kW)	0.7
Lifting motor	Rated power (kW)	3.42
Battery	Output voltage (V)	12
	Capacity (Ah)	240(20 hours discharge rate)
Charger	Nominal AC input voltage (V)	100-240VAC
	The maximum AC input current (A)	10.5
	Nominal DC output voltage (V)	24
	The maximum DC output current (A)	30
Control system	Voltage (V)	24

Oil filling amount

Items	Parameters/Content	Items	Parameters/Content
Hydraulic oil (L)	23	Gear oil for travelling reducer (L)	0.3

Floor loading information

Items	Parameters/Content	Items	Parameters/Content
Tire contact pressure (kPa)	1201	Occupied floor pressure (kPa)	8.5

Tire specification

Items	Parameters/Content	Items	Parameters/Content
Drive wheel load-6km/h (kg)	1395	Maximum static load (kg)	1630



S3246 II (S324602WDQ0AH1010) Operating Specifications

The performance parameters of the whole machine

Items	Parameters	Items	Parameters	
Rated load (kg)	320	Fork lifting time (s)	58±4	
Extended platform load (kg)	120	Fork descending time (s)	48±4	
Weight of the whole machine (kg)	2995	The maximum manual force	Indoor (N)	400
The maximum number of workers (indoor)	2		Outdoor (N)	200
The maximum number of workers (outdoor)	1	Theoretical maximum climbing ability (unloaded and with fork arms retracted)		25%
The maximum working height (m)	12	The maximum allowable tilt angle	X direction: Left/right direction	1.5°
The maximum platform height (m)	10		Y direction: Front/rear direction	3°
The minimum turning radius (m)	2.45	The maximum inner wheel angle	75°	
The maximum travelling speed (with fork arms retracted) (km/h)	3±0.5	The maximum allowable wind speed (m/s)	12.5	
The maximum travelling speed (lifting) (km/h)	0.8±0.1	Driving type	Front wheel drive	
The maximum braking distance (unloaded and with fork arms retracted) (mm)	600		Front wheel steering	

Main dimensions

Items	Parameters	Items	Parameters
Overall length (with ladder installed) (mm)	2490	Extension size of the platform (mm)	900
Overall length (without ladder) (mm)	2270	Wheelbase (mm)	1850
Machine width (mm)	1180	Tread (mm)	1050
Height of the whole machine (with guardrail not retracted) (mm)	2490	The minimum ground clearance (with fork arms retracted) (mm)	100
Height of the whole machine (with guardrail retracted) (mm)	1675	The minimum ground clearance (lifting) (mm)	20
Dimensions of the working bench (length × width) (mm)	2260×1120	Tire size (diameter x width) (mm)	Φ380×130



Hydraulic system

Items		Parameters/Content
Functional system	Type	Open system
	Pump displacement (ml/r)	4.5
	Driving system	The maximum working pressure (MPa) 25
	Lifting system	The maximum working pressure (MPa) 21
	Steering system	The maximum working pressure (MPa) 15

Electrical system

Items		Parameters/Content
Lifting motor	Rated power (kW)	4.5
Battery	Output voltage (V)	6
	Capacity (Ah)	240(20 hours discharge rate)
Charger	Nominal AC input voltage (V)	100-240VAC
	The maximum AC input current (A)	10.5
	Nominal DC output voltage (V)	24
	The maximum DC output current (A)	30
Control system	Voltage (V)	24

Oil filling amount

Items	Parameters/Content	Items	Parameters/Content
Hydraulic oil (L)	23		

Floor loading information

Items	Parameters/Content	Items	Parameters/Content
Tire contact pressure (kPa)	1201	Occupied floor pressure (kPa)	8.5

Tire specification

Items	Parameters/Content	Items	Parameters/Content
Drive wheel load-6km/h (kg)	1395	Maximum static load (kg)	1630



S3246E II (S324602WDQ0AE1010) Operating Specifications

The performance parameters of the whole machine

Items	Parameters	Items	Parameters
Rated load (kg)	320	Fork lifting time (s)	58±4
Extended platform load (kg)	120	Fork descending time (s)	48±4
Weight of the whole machine (kg)	2995	The maximum manual force	Indoor (N) 400
The maximum number of workers (indoor)	2		Outdoor (N) 200
The maximum number of workers (outdoor)	1	Theoretical maximum climbing ability (unloaded and with fork arms retracted) 25%	
The maximum working height (m)	12	The maximum allowable tilt angle	X direction: Left/right direction 1.5°
The maximum platform height (m)	10		Y direction: Front/rear direction 3°
The minimum turning radius (m)	2.45	The maximum inner wheel angle	75°
The maximum travelling speed (with fork arms retracted) (km/h)	3.5±0.2	The maximum allowable wind speed (m/s)	12.5
The maximum travelling speed (lifting) (km/h)	0.8±0.1	Driving type	Front wheel drive Front wheel steering
The maximum braking distance (unloaded and with fork arms retracted) (mm)	600		

Main dimensions

Items	Parameters	Items	Parameters
Overall length (with ladder installed) (mm)	2490	Extension size of the platform (mm)	900
Overall length (without ladder) (mm)	2270	Wheelbase (mm)	1850
Machine width (mm)	1180	Tread (mm)	1050
Height of the whole machine (with guardrail not retracted) (mm)	2490	The minimum ground clearance (with fork arms retracted) (mm)	100
Height of the whole machine (with guardrail retracted) (mm)	1675	The minimum ground clearance (lifting) (mm)	20
Dimensions of the working bench (length × width) (mm)	2260×1120	Tire size (diameter x width) (mm)	Φ380×130

Transmission system

Items	Parameters/Content
Travelling reducer	Rated output torque (Nm) 500



Hydraulic system

Items		Parameters/Content
Functional system	Type	Open system
	Pump displacement (ml/r)	4.5
	Lifting system	The maximum working pressure (MPa) 21
	Steering system	The maximum working pressure (MPa) 15

Electrical system

Items		Parameters/Content
Driving motor	Rated power (kW)	0.81
Lifting motor	Rated power (kW)	4.5
Battery	Output voltage (V)	6
	Capacity (Ah)	240(20 hours discharge rate)
Charger	Nominal AC input voltage (V)	100-240VAC
	The maximum AC input current (A)	10.5
	Nominal DC output voltage (V)	24
	The maximum DC output current (A)	30
Control system	Voltage (V)	24

Oil filling amount

Items	Parameters/Content	Items	Parameters/Content
Hydraulic oil (L)	23	Gear oil for travelling reducer (L)	0.3

Floor loading information

Items	Parameters/Content	Items	Parameters/Content
Tire contact pressure (kPa)	1311.7	Occupied floor pressure (kPa)	10.96

Tire specification

Items	Parameters/Content	Items	Parameters/Content
Drive wheel load-6km/h (kg)	1395	Maximum static load (kg)	1630



S4046E (S404602WDQ0AE1020) Operating Specifications

The performance parameters of the whole machine

Items	Parameters	Items	Parameters
Rated load (kg)	320	Fork lifting time (s)	65±4
Extended platform load (kg)	120	Fork descending time (s)	60±4
Weight of the whole machine (kg)	2970	The maximum manual force	Indoor (N)
The maximum number of workers (indoor)	2		Outdoor (N)
The maximum number of workers (outdoor)	1	Theoretical maximum climbing ability (unloaded and with fork arms retracted)	
The maximum working height (m)	14 (in)	The maximum allowable tilt angle	X direction:
	9.5 (out)		Left/right direction
The maximum platform height (m)	12 (in)		Y direction:
	7.5 (out)		Front/rear direction
The minimum turning radius (m)	2.45	The maximum inner wheel angle	75°
The maximum travelling speed (with fork arms retracted) (km/h)	3.5±0.2	The maximum allowable wind speed (m/s)	12.5
The maximum travelling speed (lifting) (km/h)	0.8±0.1	Driving type	Front wheel drive Front wheel steering
The maximum braking distance (unloaded and with fork arms retracted) (mm)	600		

Main dimensions

Items	Parameters	Items	Parameters
Overall length (with ladder installed) (mm)	2490	Extension size of the platform (mm)	900
Overall length (without ladder) (mm)	2270	Wheelbase (mm)	1850
Machine width (mm)	1180	Tread (mm)	1050
Height of the whole machine (with guardrail not retracted) (mm)	2630	The minimum ground clearance (with fork arms retracted) (mm)	100
Height of the whole machine (with guardrail retracted) (mm)	1800	The minimum ground clearance (lifting) (mm)	20
Dimensions of the working bench (length × width) (mm)	2260×1120	Tire size (diameter x width) (mm)	Φ380×130

Transmission system

Items	Parameters/Content
Travelling reducer	Rated output torque (Nm)
	500



Hydraulic system

Items		Parameters/Content
Functional system	Type	Open system
	Pump displacement (ml/r)	4.5
	Lifting system	The maximum working pressure (MPa)
	Steering system	The maximum working pressure (MPa)
		21
		15

Electrical system

Items		Parameters/Content
Driving motor	Rated power (kW)	0.7
Lifting motor	Rated power (kW)	3.42
Battery	Output voltage (V)	12
	Capacity (Ah)	150(20 hours discharge rate)
Charger	Nominal AC input voltage (V)	100-240VAC
	The maximum AC input current (A)	10.5
	Nominal DC output voltage (V)	24
	The maximum DC output current (A)	30
Control system	Voltage (V)	24

Oil filling amount

Items	Parameters/Content	Items	Parameters/Content
Hydraulic oil (L)	23	Gear oil for travelling reducer (L)	0.3

Floor loading information

Items	Parameters/Content	Items	Parameters/Content
Tire contact pressure (kPa)	1262.1	Occupied floor pressure (kPa)	10.86

Tire specification

Items	Parameters/Content	Items	Parameters/Content
Drive wheel load-6km/h (kg)	1395	Maximum static load (kg)	1630



S4046 II (S404602WDQ0AH1010) Operating Specifications

The performance parameters of the whole machine

Items	Parameters	Items	Parameters
Rated load (kg)	320	Fork lifting time (s)	65±4
Extended platform load (kg)	120	Fork descending time (s)	60±4
Weight of the whole machine (kg)	2970	The maximum manual force	Indoor (N)
The maximum number of workers (indoor)	2		Outdoor (N)
The maximum number of workers (outdoor)	1	Theoretical maximum climbing ability (unloaded and with fork arms retracted)	
The maximum working height (m)	14 (in)	The maximum allowable tilt angle	X direction: Left/right direction
	9.5 (out)		Y direction: Front/rear direction
The maximum platform height (m)	12 (in)		1.5°
	7.5 (out)		3°
The minimum turning radius (m)	2.45	The maximum inner wheel angle	75°
The maximum travelling speed (with fork arms retracted) (km/h)	3±0.5	The maximum allowable wind speed (m/s)	12.5
The maximum travelling speed (lifting) (km/h)	0.8±0.1	Driving type	Front wheel drive Front wheel steering
The maximum braking distance (unloaded and with fork arms retracted) (mm)	600		

Main dimensions

Items	Parameters	Items	Parameters
Overall length (with ladder installed) (mm)	2490	Extension size of the platform (mm)	900
Overall length (without ladder) (mm)	2270	Wheelbase (mm)	1850
Machine width (mm)	1180	Tread (mm)	1050
Height of the whole machine (with guardrail not retracted) (mm)	2630	The minimum ground clearance (with fork arms retracted) (mm)	100
Height of the whole machine (with guardrail retracted) (mm)	1800	The minimum ground clearance (lifting) (mm)	20
Dimensions of the working bench (length × width) (mm)	2260×1120	Tire size (diameter × width) (mm)	Φ380×130



Hydraulic system

Items		Parameters/Content	
Functional system	Type		Open system
	Pump displacement (ml/r)		4.5
	Driving system	The maximum working pressure (MPa)	25
	Lifting system	The maximum working pressure (MPa)	21
	Steering system	The maximum working pressure (MPa)	15
	Braking system	The maximum working pressure (MPa)	25

Electrical system

Items		Parameters/Content
Lifting motor	Rated power (kW)	4.5
Battery	Output voltage (V)	12
	Capacity (Ah)	150(20 hours discharge rate)
Charger	Nominal AC input voltage (V)	100-240VAC
	The maximum AC input current (A)	10.5
	Nominal DC output voltage (V)	24
	The maximum DC output current (A)	30
Control system	Voltage (V)	24

Oil filling amount

Items	Parameters/Content	Items	Parameters/Content
Hydraulic oil (L)	23		

Floor loading information

Items	Parameters/Content	Items	Parameters/Content
Tire contact pressure (kPa)	1262.1	Occupied floor pressure (kPa)	10.86

Tire specification

Items	Parameters/Content	Items	Parameters/Content
Drive wheel load-6km/h (kg)	1395	Maximum static load (kg)	1630



S4046E II (S404602WDQ0AE1010) Operating Specifications

The performance parameters of the whole machine

Items	Parameters	Items	Parameters
Rated load (kg)	320	Fork lifting time (s)	65±4
Extended platform load (kg)	120	Fork descending time (s)	60±4
Weight of the whole machine (kg)	2970	The maximum manual force	Indoor (N)
The maximum number of workers (indoor)	2		Outdoor (N)
The maximum number of workers (outdoor)	1	Theoretical maximum climbing ability (unloaded and with fork arms retracted)	25%
The maximum working height (m)	14 (in)	The maximum allowable tilt angle	X direction:
	9.5 (out)		Left/right direction
The maximum platform height (m)	12 (in)		Y direction:
	7.5 (out)		Front/rear direction
The minimum turning radius (m)	2.45	The maximum inner wheel angle	75°
The maximum travelling speed (with fork arms retracted) (km/h)	3.5±0.2	The maximum allowable wind speed (m/s)	12.5
The maximum travelling speed (lifting) (km/h)	0.8±0.1	Driving type	Front wheel drive Front wheel steering
The maximum braking distance (unloaded and with fork arms retracted) (mm)	600		

Main dimensions

Items	Parameters	Items	Parameters
Overall length (with ladder installed) (mm)	2490	Extension size of the platform (mm)	900
Overall length (without ladder) (mm)	2270	Wheelbase (mm)	1850
Machine width (mm)	1180	Tread (mm)	1050
Height of the whole machine (with guardrail not retracted) (mm)	2630	The minimum ground clearance (with fork arms retracted) (mm)	100
Height of the whole machine (with guardrail retracted) (mm)	1800	The minimum ground clearance (lifting) (mm)	20
Dimensions of the working bench (length × width) (mm)	2260×1120	Tire size (diameter x width) (mm)	Φ380×130

Transmission system

Items	Parameters/Content
Travelling reducer	Rated output torque (Nm) 500



Hydraulic system

Items		Parameters/Content
Functional system	Type	Open system
	Pump displacement (ml/r)	4.5
	Lifting system	The maximum working pressure (MPa)
	Steering system	The maximum working pressure (MPa)
		21
		15

Electrical system

Items		Parameters/Content
Driving motor	Rated power (kW)	0.81
Lifting motor	Rated power (kW)	4.5
Battery	Output voltage (V)	12
	Capacity (Ah)	150(20 hours discharge rate)
Charger	Nominal AC input voltage (V)	100-240VAC
	The maximum AC input current (A)	10.5
	Nominal DC output voltage (V)	24
	The maximum DC output current (A)	30
Control system	Voltage (V)	24

Oil filling amount

Items	Parameters/Content	Items	Parameters/Content
Hydraulic oil (L)	23	Gear oil for travelling reducer (L)	0.3

Floor loading information

Items	Parameters/Content	Items	Parameters/Content
Tire contact pressure (kPa)	1262.1	Occupied floor pressure (kPa)	10.86

Tire specification

Items	Parameters/Content	Items	Parameters/Content
Drive wheel load-6km/h (kg)	1395	Maximum static load (kg)	1630



S4650E (S465002WDQ0AE1020) Operating Specifications

The performance parameters of the whole machine

Items	Parameters	Items	Parameters
Rated load (kg)	320	Fork lifting time (s)	80±4
Extended platform load (kg)	120	Fork descending time (s)	65±4
Weight of the whole machine (kg)	3500	The maximum manual force	Indoor (N)
The maximum number of workers (indoor)	2		Outdoor (N)
The maximum number of workers (outdoor)	1	Theoretical maximum climbing ability (unloaded and with fork arms retracted)	
The maximum working height (m)	15.8 (in) 10 (out)	The maximum allowable tilt angle	X direction: Left/right direction
The maximum platform height (m)	13.8 (in) 8 (out)		Y direction: Front/rear direction
The minimum turning radius (m)	2.85	The maximum inner wheel angle	75°
The maximum travelling speed (with fork arms retracted) (km/h)	3.5±0.2	The maximum allowable wind speed (m/s)	12.5
The maximum travelling speed (lifting) (km/h)	0.8±0.1	Driving type	Front wheel drive Front wheel steering
The maximum braking distance (unloaded and with fork arms retracted) (mm)	600		

Main dimensions

Items	Parameters	Items	Parameters
Overall length (with ladder installed) (mm)	2800	Extension size of the platform (mm)	900
Overall length (without ladder) (mm)	2650	Wheelbase (mm)	2220
Machine width (mm)	1300	Tread (mm)	1175
Height of the whole machine (with guardrail not retracted) (mm)	2740	The minimum ground clearance (with fork arms retracted) (mm)	105
Height of the whole machine (with guardrail retracted) (mm)	1940	The minimum ground clearance (lifting) (mm)	20
Dimensions of the working bench (length × width) (mm)	2640×1120	Tire size (diameter x width) (mm)	Φ380×130

Transmission system

Items	Parameters/Content
Travelling reducer	Rated output torque (Nm) 500



Hydraulic system

Items		Parameters/Content	
Functional system	Type		Open system
	Pump displacement (ml/r)		4.5
	Lifting system	The maximum working pressure (MPa)	21
	Steering system	The maximum working pressure (MPa)	16.5

Electrical system

Items		Parameters/Content
Driving motor	Rated power (kW)	0.7
Lifting motor	Rated power (kW)	3.42
Battery	Output voltage (V)	12
	Capacity (Ah)	150(20 hours discharge rate)
Charger	Nominal AC input voltage (V)	100-240VAC
	The maximum AC input current (A)	10.5
	Nominal DC output voltage (V)	24
	The maximum DC output current (A)	30
Control system	Voltage (V)	24

Oil filling amount

Items	Parameters/Content	Items	Parameters/Content
Hydraulic oil (L)	25.5	Gear oil for travelling reducer (L)	0.3

Floor loading information

Items	Parameters/Content	Items	Parameters/Content
Tire contact pressure (kPa)	1255.6	Occupied floor pressure (kPa)	10.1

Tire specification

Items	Parameters/Content	Items	Parameters/Content
Drive wheel load-6km/h (kg)	1395	Maximum static load (kg)	1630



S4650 II (S465002WDQ0AH1010) Operating Specifications

The performance parameters of the whole machine

Items	Parameters	Items	Parameters
Rated load (kg)	320	Fork lifting time (s)	80±4
Extended platform load (kg)	120	Fork descending time (s)	65±4
Weight of the whole machine (kg)	3500	The maximum manual force	Indoor (N)
The maximum number of workers (indoor)	2		Outdoor (N)
The maximum number of workers (outdoor)	1	Theoretical maximum climbing ability (unloaded and with fork arms retracted)	25%
The maximum working height (m)	15.8 (in) 10 (out)	The maximum allowable tilt angle	X direction: Left/right direction
The maximum platform height (m)	13.8 (in) 8 (out)		Y direction: Front/rear direction
The minimum turning radius (m)	2.85	The maximum inner wheel angle	75°
The maximum travelling speed (with fork arms retracted) (km/h)	3±0.5	The maximum allowable wind speed (m/s)	12.5
The maximum travelling speed (lifting) (km/h)	0.8±0.1	Driving type	Front wheel drive Front wheel steering
The maximum braking distance (unloaded and with fork arms retracted) (mm)	600		

Main dimensions

Items	Parameters	Items	Parameters
Overall length (with ladder installed) (mm)	2800	Extension size of the platform (mm)	900
Overall length (without ladder) (mm)	2650	Wheelbase (mm)	2220
Machine width (mm)	1300	Tread (mm)	1175
Height of the whole machine (with guardrail not retracted) (mm)	2740	The minimum ground clearance (with fork arms retracted) (mm)	105
Height of the whole machine (with guardrail retracted) (mm)	1940	The minimum ground clearance (lifting) (mm)	20
Dimensions of the working bench (length × width) (mm)	2640×1120	Tire size (diameter x width) (mm)	Φ380×130



Hydraulic system

Items		Parameters/Content
Functional system	Type	Open system
	Pump displacement (ml/r)	4.5
	Driving system	The maximum working pressure (MPa)
	Lifting system	The maximum working pressure (MPa)
	Steering system	The maximum working pressure (MPa)
Braking system	The maximum working pressure (MPa)	25

Electrical system

Items		Parameters/Content
Lifting motor	Rated power (kW)	4.5
Battery	Output voltage (V)	12
	Capacity (Ah)	150(20 hours discharge rate)
Charger	Nominal AC input voltage (V)	100-240VAC
	The maximum AC input current (A)	10.5
	Nominal DC output voltage (V)	24
	The maximum DC output current (A)	30
Control system	Voltage (V)	24

Oil filling amount

Items	Parameters/Content	Items	Parameters/Content
Hydraulic oil (L)	25.5		

Floor loading information

Items	Parameters/Content	Items	Parameters/Content
Tire contact pressure (kPa)	1255.6	Occupied floor pressure (kPa)	10.1

Tire specification

Items	Parameters/Content	Items	Parameters/Content
Drive wheel load-6km/h (kg)	1395	Maximum static load (kg)	1630



S4650E II (S465002WDQ0AE1010) Operating Specifications

The performance parameters of the whole machine

Items	Parameters	Items	Parameters
Rated load (kg)	320	Fork lifting time (s)	80±4
Extended platform load (kg)	120	Fork descending time (s)	65±4
Weight of the whole machine (kg)	3500	The maximum manual force	Indoor (N)
The maximum number of workers (indoor)	2		Outdoor (N)
The maximum number of workers (outdoor)	1	Theoretical maximum climbing ability (unloaded and with fork arms retracted)	
The maximum working height (m)	15.8 (in) 10 (out)	The maximum allowable tilt angle	X direction: Left/right direction
The maximum platform height (m)	13.8 (in) 8 (out)		Y direction: Front/rear direction
The minimum turning radius (m)	2.85	The maximum inner wheel angle	75°
The maximum travelling speed (with fork arms retracted) (km/h)	3.5±0.2	The maximum allowable wind speed (m/s)	12.5
The maximum travelling speed (lifting) (km/h)	0.8±0.1	Driving type	Front wheel drive Front wheel steering
The maximum braking distance (unloaded and with fork arms retracted) (mm)	600		

Main dimensions

Items	Parameters	Items	Parameters
Overall length (with ladder installed) (mm)	2800	Extension size of the platform (mm)	900
Overall length (without ladder) (mm)	2650	Wheelbase (mm)	2220
Machine width (mm)	1300	Tread (mm)	1175
Height of the whole machine (with guardrail not retracted) (mm)	2740	The minimum ground clearance (with fork arms retracted) (mm)	105
Height of the whole machine (with guardrail retracted) (mm)	1940	The minimum ground clearance (lifting) (mm)	20
Dimensions of the working bench (length × width) (mm)	2640×1120	Tire size (diameter x width) (mm)	Φ380×130

Transmission system

Items	Parameters/Content
Travelling reducer	Rated output torque (Nm) 500



Hydraulic system

Items		Parameters/Content	
Functional system	Type		Open system
	Pump displacement (ml/r)		4.5
	Lifting system	The maximum working pressure (MPa)	21
	Steering system	The maximum working pressure (MPa)	16.5

Electrical system

Items		Parameters/Content
Driving motor	Rated power (kW)	0.81
Lifting motor	Rated power (kW)	4.5
Battery	Output voltage (V)	12
	Capacity (Ah)	150(20 hours discharge rate)
Charger	Nominal AC input voltage (V)	100-240VAC
	The maximum AC input current (A)	10.5
	Nominal DC output voltage (V)	24
	The maximum DC output current (A)	30
Control system	Voltage (V)	24

Oil filling amount

Items	Parameters/Content	Items	Parameters/Content
Hydraulic oil (L)	25.5	Gear oil for travelling reducer (L)	0.3

Floor loading information

Items	Parameters/Content	Items	Parameters/Content
Tire contact pressure (kPa)	1255.6	Occupied floor pressure (kPa)	10.1

Tire specification

Items	Parameters/Content	Items	Parameters/Content
Drive wheel load-6km/h (kg)	1395	Maximum static load (kg)	1630



 **NOTICE:** The ground bearing information is approximate information, and the different options are not included. The information can be used only if the safety factor is high enough. The weight of the machine varies according to the configuration of the selected part.

10.1 Hydraulic Oil Specifications

 **NOTICE:** When filling the hydraulic oil tank, it is a requirement to use the proper hydraulic oil in accordance with the work site environment and ambient temperature with reference to the following:

Grade	Brand
Rando MV32	Chevron

