



Operation Manual

ANSI/SAIA A92.20-2018 & CSA B354.6-17

AR45J/AR52J

**Mobile Elevating
Work Platforms**

PART No. OM-2537050837

Original Instructions

Original Instructions

Thank you for choosing to use this Mobile Elevating Work Platform from LGMG , All models are designed and manufactured according to ANSI/SAIA A92.20-2018 & CSA B354.6-17, All dealers, owners, users, operators, lessors, lessees, and brokers to comply with appropriate section(s) of applicable ANSI/SAIA A92.20-2018 standards.

This manual is a guide for safe and proper operation and maintenance of the machine, which introduces technical parameters and mechanism and operation herein.

We sincerely hope that you will read through this manual before attempting to operate the machine for the first time and before repairing and maintaining the machine, and that you will master the operation and maintenance described therein.

The information contained in this manual is correct at the time of publication. However, LGMG has endeavored to deliver the highest degree of accuracy possible. And continuous improvement of our product is a LGMG policy. Therefore, product specifications are subject to change without notice.

Due to the impossibility of foreseeing all possible hazards, therefore, it is not possible to include all safety precautions in this manual and the machine's safety precautions in this manual and the machine's safety instructions. If some operations that are not recommended in this manual, you must ensure that you and others are safe and will not damage the machine. If the security of certain operations cannot be determined, please call LGMG industries or dealer service center.

The precautions for operation and maintenance contained in this manual are only applicable when the machine is used for the specified use. If the machine is used within the scope not listed in this manual, our company will not assume any safety responsibility, which is borne by the user and operator in such operations.

Any prohibited operations in this manual shall not be performed.

This manual should always be placed in the designated location for read. This manual is part of the machine, when the ownership or use right of the machine is transferred, please hand over this manual together. If the manual is lost, damaged or illegible, please replace it promptly.

The copyright of this manual this manual is authorized to LGMG and it cannot be copied or reprinted without LGMG's written permission.

2026-03 Version 1 Printed 1

LINGONG HEAVY MACHINERY CO.,LTD.

Add: 2676 Kejia Road, high tech Zone, Jinan City, Shandong Province, China

Tel: 86-0531-67601108

Fax: 86-0531-67601108

Service Tel: 86-0531-67605016

Web: www.lgmg.com.cn



Contents

Contents	I
Safety Precautions	V
Chapter 1 Safety	1
1.1 Danger	3
1.2 No Operation Is Allowed Unless.....	3
1.3 Classification of Hazards	3
1.4 Intended Purpose	4
1.5 Safety Sign Maintenance	4
1.6 Electric Shock Hazard.....	4
1.7 Tip-over Hazard.....	5
1.8 Safety in the Work Area.....	5
1.9 Crushing Hazard.....	6
1.10 Hazard of Operating on Slopes	7
1.11 Fall Hazard.....	7
1.12 Collision Hazard	7
1.13 Component Damage Hazard	8
1.14 Explosion and Combustion Hazard	8
1.15 Machine Damage Hazard	8
1.16 Bodily Injury Hazard.....	9
1.17 Battery Safety	9
1.18 Ground Information	9
1.19 Locked After Each Use.....	10



1.20 Check Tires and Wheels	10
Chapter 2 Legend	13
Chapter 3 Decals	17
Chapter 4 Specification.....	27
Chapter 5 Control Unit	53
5.1 Lower Control Box	55
5.2 Upper Control Box.....	63
5.3 Control Logic (SPD).....	67
Chapter 6 Pre-Operation Inspection	69
6.1 No Operation Is Allowed Unless.....	71
6.2 Basic Principles.....	71
6.3 Pre-Operation Inspection.....	71
6.4 Pre-operation Inspection of Safety Protection Devices (SPD)	72
6.5 Machine inspection diagram	73
Chapter 7 Workplace Inspection	77
7.1 No Operation Is Allowed Unless.....	79
7.2 Basic Principles.....	79
7.3 Workplace Inspection.....	79
Chapter 8 Functional Test.....	81
8.1 No Operation Is Allowed Unless.....	83
8.2 Basic Principles.....	83
8.3 Functional Test	83
8.4 Tests from the Lower Control Box	83



8.5 Tests from the Upper Control Box	84
Chapter 9 Operating Instructions.....	89
9.1 No Operation is Allowed Unless.....	91
9.2 Basic Principles	91
9.3 Starting the Engine.....	91
9.4 Emergency Stop	92
9.5 Emergency Power	92
9.6 Operation from the Ground Control Station.....	92
9.7 Operation from the Platform Control Station	92
9.8 Platform Overload	94
9.9 Tilt Indicator	94
9.10 System Fault	95
9.11 Parking and Storage.....	97
9.12 Function of Safety Protection Devices (SPD)	97
9.13 Low Temperature Start Kit (If Equipped)	98
9.14 DPF Regeneration (If Equipped).....	99
9.15 Fall Protection.....	101
Chapter 10 Instructions for Transportation and Lifting.....	103
10.1 Compliance	105
10.2 Freewheel Configuration for Trailers	105
10.3 Transportation Safety.....	105
10.4 Lifting Instructions	106





Safety Precautions

The operator of this machine shall understand and follow the existing safety regulations of state and local governments. If these are unavailable, the safety instructions in this manual shall be followed.

To help prevent accidents, read and understand all warnings and precautions in this manual before operation or performing maintenance.

The safety measures are specified in Chapter 1 Safety.

It is impossible to foresee every possible hazard and the safety instructions in this manual may not cover all safety prevention measures. Always ensure the safety of all personnel and protect the machine against any damage. If unable to confirm the safety of some operations, contact LGMG North America.

The operation & maintenance prevention measures listed in this manual are only applicable to the specified uses of this machine. LGMG North America assumes no responsibility if this machine is used beyond the range of this manual. The user and the operator shall be responsible for the safety of such operations.

Do not perform any operation forbidden in this manual in any situation.

The following signal words are applicable for identifying the level of safety information in this manual.

Danger:

An imminent situation, that if not avoided, will result in severe injuries or death. This is also applicable to situations that will cause serious machine damage, if not avoided.

Warning:

A potentially dangerous situation, that if not avoided, may result in severe injuries or death. This is also applicable to situations that may cause serious machine damage, if not avoided.

Notice:

A situation, that if not avoided, may result in minor or intermediate injury. This is also applicable to situations that may cause machine damage or shorten machine service life.





Chapter 1 Safety





1.1 Danger

Failure to follow the instructions and safety rules in this manual may cause death or serious injury.

1.2 No Operation Is Allowed Unless

You have understood and practiced the rules for safe operation of the vehicle in this manual.

- 1) Avoid dangerous situations. Know and understand the safety rules before proceeding with the next step.
- 2) Always perform a pre-operation inspection.
- 3) Always perform a pre-use functional test.
- 4) Check the workplace.
- 5) Use the vehicle only for its intended purpose.
- 6) Read, understand, and follow the manufacturer's instructions and safety rules - safe operation manuals and vehicle labels.
- 7) Read, understand and follow user safety rules and work site regulations.
- 8) Read, understand and follow all applicable government laws and regulations.
- 9) You have received the training on safe operation of the vehicle.

1.3 Classification of Hazards



Classification of hazards

The meanings of symbols, color codes and characters of LGMG North America's products are as follows:

Security warning symbol: are used for warning of potential personal injuries. Observe all safety instructions below these signs, to avoid situations causing potential personal injury and death.



Red: Signifies dangerous situations. If not avoided, will result in personal death or severe injury.



Orange: Signifies dangerous situations. If not avoided, may result in personal death or severe injury.



Yellow: Signifies dangerous situations. If not avoided, may result in minor or intermediate personal injury.



Notice

Blue: Signifies dangerous situations. If not avoided, property loss or damage can occur.

1.4 Intended Purpose

This vehicle is only used to lift operators and their tools and materials to high-altitude workplaces.



It is strictly forbidden to use the machine to carry loads.

1.5 Safety Sign Maintenance

- 1) The operators should always keep in mind their safety when replacing any missing or damaged safety signs.
- 2) The safety decal should be cleaned with mild soap and water.
- 3) Do not use solvent-based cleaners as they may damage the material of the safety label.

- 2) This machine should be kept an adequate safety distance from power line and electrical equipment according to applicable government laws and regulations and the following table.

Voltage	Required safety distance
0~50KV	10ft
50KV~200KV	15ft
200KV~350KV	20ft
350KV~500KV	25ft
500KV~750KV	35ft
750KV~1000KV	45ft

1.6 Electric Shock Hazard

- 1) This machine is not insulated and is not provided with electrical shock protection when it comes into contact with or near electrical wire.

- 3) The effects of strong winds or gusts on the movement of the platform, the swinging and slackening of the wires should be considered.
- 4) If the machine comes into contact with live wires, keep away from the vehicle. No one is allowed to touch or operate the vehicle on the ground or platform before cutting off the power supply.



- 5) Do not operate the machine when there is lightning or storms.
- 6) Do not use the machine as a ground wire when welding.

1.7 Tip-over Hazard

The personnel, equipment and materials on the platform may not exceed the maximum load capacity of the platform.

Maximum load	AR45J/AR52J
Maximum number of people	2 people
Maximum allowable wind speed	12.5m/s/28mph
Maximum platform working load	230kg/510lbs

1.8 Safety in the Work Area

- 1) The boom can be lifted or extended only when the vehicle is on a solid, flat surface.



- 2) When the platform is lifted, drive speed may not exceed 0.8km/h/0.5mph.
- 3) The tilt sensor may not be used as a level indicator. The alarm on the turntable will sound only when the vehicle is heavily tilted.
- 4) When the alarm sounds: Do not extend, rotate or lift the boom beyond the horizontal plane. The vehicle should be moved to a solid, flat surface before lifting the platform. If the alarm sounds when lifting the platform, the boom should be telescoped carefully and the platform should be lowered. Do not rotate the boom during lowering. The vehicle should be moved to a solid, flat surface before lifting the platform.
- 5) For outdoor operation, do not lift the boom when the wind speed may exceed 12.5 m/s/28mph. If the wind speed exceeds 12.5 m/s/28mph after the boom is lifted, the boom should be lowered and do not continue to operate the vehicle.
- 6) Do not operate the vehicle in strong winds or gusts. Do not increase the surface area of the platform or load. Increasing the area exposed to the wind will reduce the stability of the vehicle.
- 7) Do not operate the vehicle with the upper control box when the platform is caught, jammed, or other nearby objects are blocking its normal movement. If you want to operate the vehicle with the lower control box, you must operate it after all personnel have left the platform.
- 8) In the telescoped state, the vehicle should be operated carefully and slow down when driving on uneven terrain, gravel, unstable or smooth surfaces, near holes or steep slopes.



- 9) When the boom is lifted or extended, the vehicle may not drive on uneven terrain, unstable surfaces, or other dangerous conditions, or near these areas.
- 10) Do not push or pull any object that is outside the platform.
- 11) Do not use the vehicle as a crane.
- 12) Do not place, tie, or hang any loads on any part of the vehicle.



- 13) Do not use the boom to push the vehicle or other object.
- 14) Do not make the boom contact adjacent components.
- 15) The limit button switch may not be changed or disabled.
- 16) The boom or platform may not be tied to adjacent components.
- 17) The load may not be placed outside the perimeter of the platform.
- 18) Do not modify the elevating work platform without the prior written permission of the manufacturer. Installing additional equipment for placing tools or other materials on the platform, pedal plate or guardrail will increase the weight of the platform and

the surface area of the platform or increase the load.

- 19) Do not modify or damage any parts that may affect the safety and stability of the vehicle.
- 20) Key parts that affect the vehicle's stability may not be replaced with parts of different weights or specifications.
- 21) Do not place the ladder or scaffolding in the platform or against any part of the vehicle.
- 22) Only tools and materials that are evenly distributed and can be safely moved by people on the platform can be transported.
- 23) Do not operate the vehicle on a moving surface or on a vehicle.
- 24) Make sure all tires are in good conditions and the nuts are properly tightened.
- 25) The ambient temperature in which the vehicle is operated is $-20^{\circ}\text{C} \sim 40^{\circ}\text{C}$.
- 26) The allowable fluctuation of the vehicle's supply voltage is $\pm 10\%$.

1.9 Crushing Hazard

- 1) Do not place arms, hands, or fingers in any position where there is a hazard of potential crushing.
- 2) When the machine is being operated from the ground using the control unit, use good judgment and carefully plan the travel path of the machine and boom. Keep a safe distance between the operator, machine and any fixed objects, walls, or buildings.



1.10 Hazard of Operating on Slopes

Do not drive the vehicle on a slope that exceeds the vehicle's slope and side slope ratings. The slope rating applies to the vehicle that is in the retracted state.

Maximum slope rating, stowed position

Platform downhill	30% (17°)
Platform uphill	45% (24°)
Side slope	25% (14°)



When the vehicle is going downhill, select the slow speed mode (turtle) set at the upper control!

1.11 Fall Hazard

- 1) During operation, the personnel on the platform must wear the full body safety device and secure it with a seat belt hook to the approved rope attachment point. Only one hook can be tied to each rope attachment point.
- 2) Do not sit, stand or climb on the guardrail of the platform. Always stand on the platform floor firmly.



- 3) After the platform is lifted, the operator may not climb down the boom.
- 4) Keep the platform floor free of debris.
- 5) Lower the platform entry lifting rod or close the entry door before operating.
- 6) Do not operate the vehicle if the guardrail is not installed properly or the entrance door fails to guarantee safe operation.
- 7) Do not enter or exit the platform unless the vehicle is in the telescoped state.

1.12 Collision Hazard

- 1) When starting or operating the vehicle, pay attention to the blind spots within the line of sight.
- 2) When rotating the turntable, pay attention to the position of the boom and the tail of the turntable.
- 3) Check the work area to avoid obstacles or other possible hazards.





- 4) When holding onto the platform guardrail, be careful of the risk of crushing.
- 5) Lower the boom when there are no people or obstacles in the area underneath.

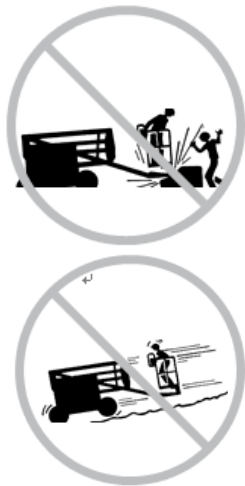

- 6) Limit the drive speed according to the ground conditions, congestion levels, slope, personnel location and any other factors that may cause a collision.
- 7) It is not allowed to operate the machine on any crane or moving overhead vehicle route unless the crane control unit has been locked and/or precautions have been taken to prevent any potential collision.
- 8) When operating the machine, avoid any dangerous behaviors.
- 9) Users must abide by user rules, workplace rules and government rules regarding the use of personal protective equipment.
- 10) The direction arrows of the drive and steering function of the upper control box should be noted.

1.13 Component Damage Hazard

- 1) Do not use any battery or charger greater than 12 V to start the engine.
- 2) Do not use the machine as the ground wire during welding.
- 3) Do not use the machine in the place where there may be magnetic field.

1.14 Explosion and Combustion Hazard

- 1) Do not operate the vehicle where it is dangerous or where flammable or explosive gases or particles may be present.
- 2) Do not start up the engine if liquefied petroleum gas (LPG), gasoline, diesel, or other explosive substances are present.
- 3) Do not refuel the machine when the engine is running.
- 4) Only refuel the machine in open and well-ventilated places far away from sparks, open flames, burning cigarettes, etc.

1.15 Machine Damage Hazard

- 1) Do not operate a machine that is damaged or faulty.
- 2) Before each work shift, thoroughly perform the pre-operation inspection against the vehicle and test all functions. A damaged or faulty vehicle should be immediately tagged out and stopped.
- 3) Make sure all maintenance operations have been performed as specified in this manual.



- 4) Make sure all decals are properly positioned and easily identifiable.
- 5) Make sure this manual is stored in the manual box on the platform.

1.16 Bodily Injury Hazard

- 1) Do not operate the vehicle with hydraulic oil leaks, which may penetrate when under pressure or burn your skin.
- 2) Incorrect contact with any component under the cover may cause serious injury. Only qualified authorized service personnel can access the compartment. It is recommended that the operator perform the inspection only during the pre-operation inspection. All compartments must be closed and locked during operation.
- 3) Always operate the machine in a well-ventilated area to avoid of carbon monoxide poisoning.
- 4) It is forbidden to carry out maintenance work when the equipment is electrically charged or the hydraulic system is under pressure.

1.17 Battery Safety

Burn Hazard

- 1) The battery contains acidic substances. Wear protective clothing and goggles when maintaining the battery.



- 2) Avoid spilling or touching the acid in the battery. Soda and water can be used to neutralize the spilled battery acid.

- 3) When the vehicle is not operated for a long time, turn off the main power switch.

Explosion Hazard



- 1) Sparks, flames and lit cigarettes are prohibited from getting close to the battery. The battery can release explosive gases.
- 2) Do not touch the battery terminals or cable clamps with tools that may cause sparks.

Electric Shock/Burn Hazard

- 1) Avoid electric shock due to contact with battery terminals. Remove all rings, watches and other accessories.

1.18 Ground Information



WARNING: Rollover and personal injury will be caused under severe working conditions and complex and unsafe ground conditions, and stable ground conditions and good working conditions can ensure the normal operation of the machine; therefore before operation, verify that the ground in the working area is safe and strong enough to support the machine.



DANGER: Rollover and

personal injury may occur under the following conditions:

- On steep slopes or in caves;
- When there are protrusions, obstacles or debris on the ground;
- On the inclined surface;
- On the unstable or smooth surface;
- Near the mining area where the soil foundation is soft soil;
- On saturated soil or frozen soil;
- On suspended floor;
- On kerbs and road edges;
- On surface support that is not strong enough to withstand the full load of the machine;
- Under other possible unsafe situations.

The ground load bearing information of the machine is shown in the table below:

Model	Tire contact pressure (Kpa/psi)	Occupied floor pressure (Kpa/psi)
AR45J	587.89/85.3	10.38/1.51
AR52J	624.20/90.5	11.74/1.7

Ground load bearing information



CAUTION: The ground load

bearing information given herein is for reference only, and does not consider the optional devices of the machine. Before using the machine, always verify that the ground of the working area is safe and strong enough to support the machine.

Tire specification:

Model	Drive wheel load-6km/h (Kg/lbs)	Maximum static load (Kg/lbs)
AR45J	4000/8818	4380/9656
AR52J	4000/8818	4380/9656

Tire specification

1.19 Locked After Each Use

- 1) Choose a safe parking location that can be a solid, flat surface without obstructions or heavy traffic.
- 2) Telescope the boom and lower the platform.
- 3) Rotate the turntable to make the boom located between non-steering wheels.
- 4) Turn the key switch to the "OFF" position and remove the key to avoid any unauthorized use.
- 5) Cut off the power when the machine is repaired or not used for a long period.

1.20 Check Tires and Wheels

This check item is conducted every 250 hours or once per quarter, whichever comes



first.

Keeping tires and hubs in a good condition is critical for safe operation and good performance. Failure of the tires and hubs may cause the platform to tilt. If such failure is not found and repaired in time, it will also cause damage to platform parts.

- 1) Check treads and sides of tires for scratches, cracks, punctures, and other abnormal wear.
- 2) Check if the wheels are damaged, bent or cracked.
- 3) Check whether or not the sealing screws for tires are missing. If missing screws, if there is slight or no leakage of fillers, and no significant deformation is found for the tire body, and users can knock in screws which are slightly larger than the diameter (about 5mm/2in) of the vent hole with a hammer. If leakage of a large quantity of filler is found, and the tire body deforms significantly, lower the platform and replace the tires immediately.





Chapter 2 Legend



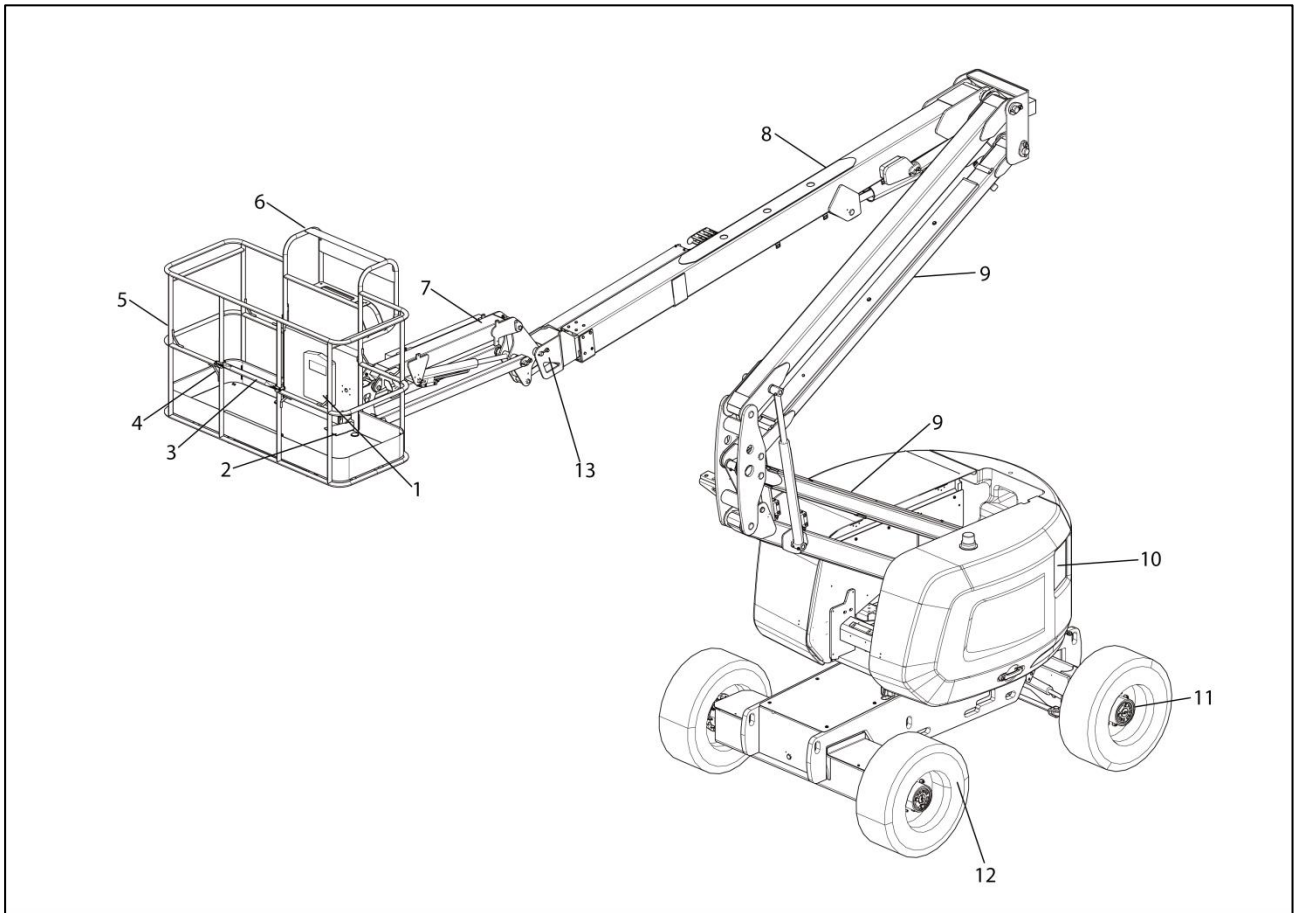

No.	Name	No.	Name
1	File Box	7	Jib
2	Foot Switch	8	Base Boom Section
3	Lifting Rod	9	Tower Boom Section
4	Lanyard Fixing Point	10	Lower Control Box
5	Platform	11	Steering Wheel
6	Upper Control Box	12	Non-Steering Wheel
		13	Fly Boom Section





Chapter 3 Decals





Label

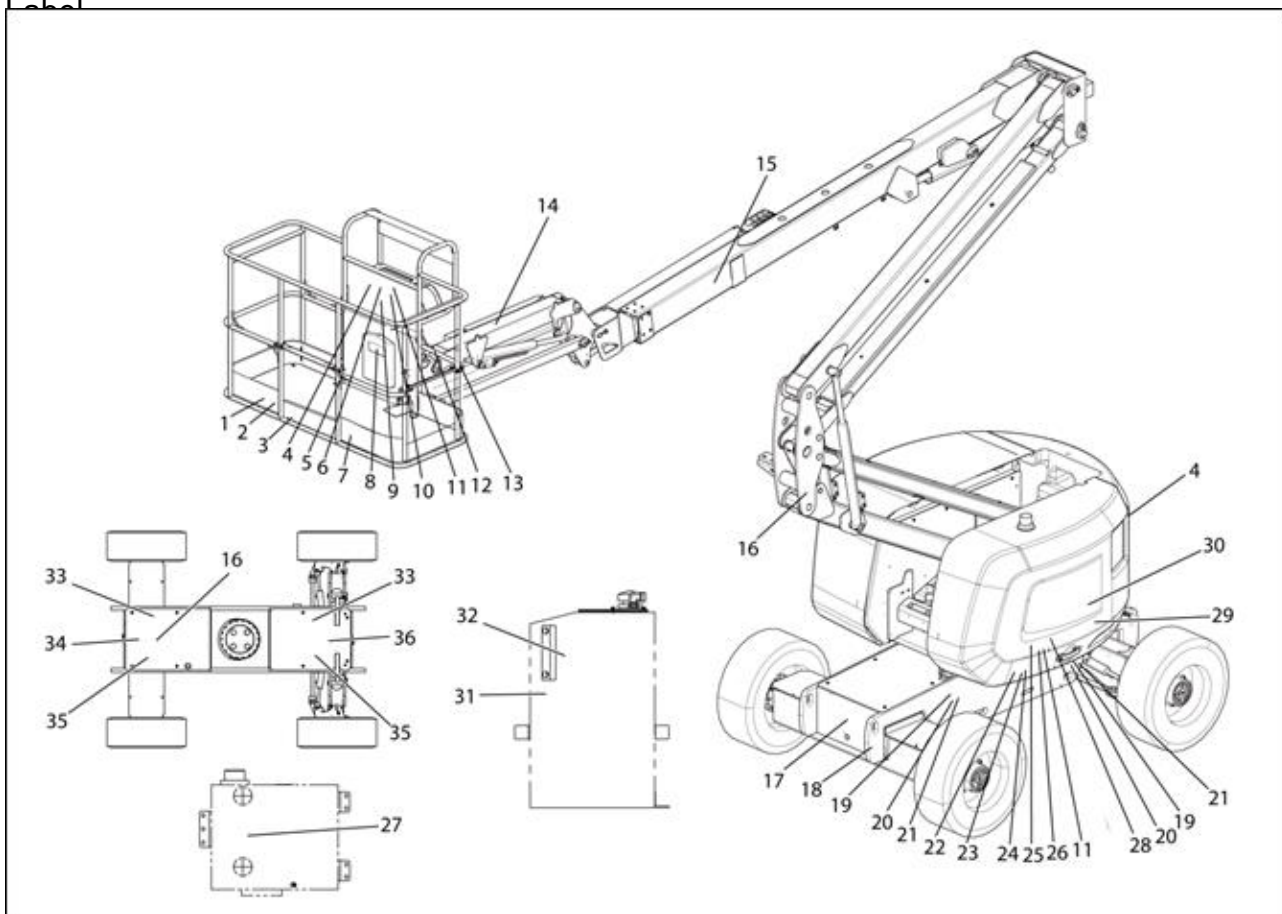



Operation and Safety Manual

1-2534001559



2-2534001560

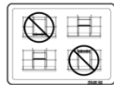

3-2534000024



4-2534001540



5-2534000248



6-2534001541



7-2534001565



8-2534001542

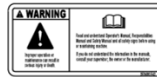

9-2534001762

NON-INSULATED

10-2534001570



11-2534000026



12-2534000017



13-2534001809



14-2534001180



15-2534001749



16-2534001545



17-2534000056

4x4

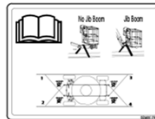

19-2534001848



20-2534001849



21-2534001578



22-2534001543



23-2534001558



24-2534001546



25-2534001548

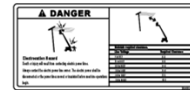

26-2534000998



27-2534000177



28-2534001080



29-2534001846/52

AR46J
AR52J

30-2534000368



31-2534001567



32-2534001377



33-2534000051



34-2534000052



35-2534000050



36-2534000053

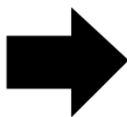



No.	Code	Name
1	2534001559	Maximum hand power sign
2	2534001560	Middle guardrail lifting and lowering attention sign
3	2534000024	Warning line
4	2534001540	Safety rules description sign
5	2534000248	Anti-scratch
6	2534001541	Uphill and downhill tipping attention sign
7	2534001565	Warning sign of platform safety
8	2534001542	Instructions reading sign
9	2534001762	No-insulated sign
10	2534001570	Manual missing instruction
11	2534000026	Instructions reading sign
12	2534000017	Lanyard fixing point sign
13	2534001809	Anti-scratch
14	2534001180	Anti-falling attention sign
15	2534001749	Group LOGO-LGMG
16	2534001545	Anti-rollover danger sign
17	2534000056	Drive type identification
18	2534001178	Lanyard fixing point sign
19	2534001848	Tire change attention sign
20	2534001849	Wheel load sign
21	2534001578	Anti-rollover attention sign
22	2534001543	Anti-crashing danger sign
23	2534001558	Pay attention to hazardous material
24	2534001546	Explosion burn warning sign
25	2534001548	Anti-electric shock warning sign
26	2534000998	"No fire" warning sign



27	2534000177	Fuel tank sign
28	2534001080	"No fire" warning sign
29	2534001846/52	Model mark
30	2534000368	Group LOGO-right
31	2534001567	Hydraulic oil sign
32	2534001377	Hydraulic oil sign
33	2534000051	Arrow sign
34	2534000052	Arrow sign
35	2534000050	Arrow sign
36	2534000053	Arrow sign





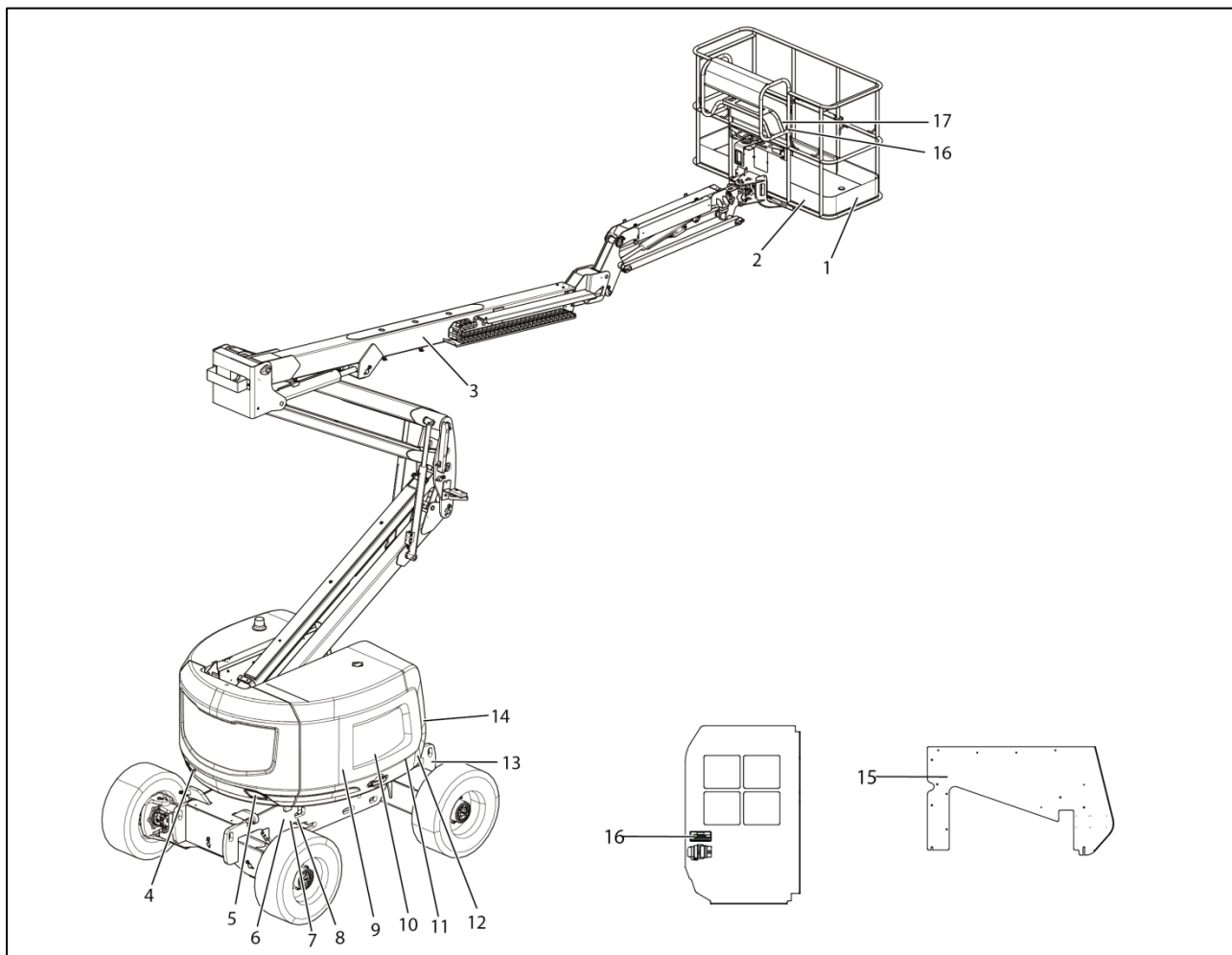









Label



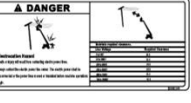
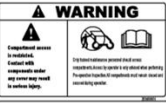
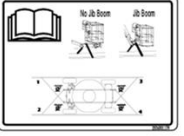

Operation and Safety Manual

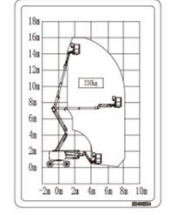
<p>1-2534000024</p> 	<p>2-2534001544</p> 	<p>3-2534001847/53</p> <p>AR45J AR52J</p>	<p>4-2534000362</p> 	<p>5-2534000363</p> 
<p>6-2534001848</p> 	<p>7-2534001849</p> 	<p>8-2534001578</p> 	<p>9-2534001846/52</p> <p>AR45J AR52J</p>	<p>10-2534000367</p> 
<p>11-2534001548</p> 	<p>12-2534000974</p> 	<p>13-2534001178</p> 	<p>14-2534001545</p> 	<p>15-2534001742</p> <p>Battery disconnect switch</p>
<p>16-2534001850</p> 	<p>17-2534002551</p> 	<p>18-2534002554/5</p> 		



Operation and Safety Manual

No	Code	Name
1	2534000024	Warning line
2	2534001544	Keeping away from vehicle warning sign
3	2534001847/53	Model sign
4	2534000362	Reflective sticker
5	2534000363	Reflective sticker
6	2534001848	Tire change attention sign
7	2534001849	Wheel load sign
8	2534001578	Anti-rollover attention sign
9	2534001846/52	Model sign
10	2534000367	Company Logo-left
11	2534001548	Anti-electric shock warning sign
12	2534000974	In-box maintenance attention sign
13	2534001178	Lanyard fixing point sign
14	2534001545	Anti-rollover attention sign
15	2534001742	Power switch
16	2534001850	Vehicle nameplate
17	2534002551	Label-Slop rating
18	2534002554/5	Label- Range of motion





Chapter 4 Specification





AR45J (A0014JNDAH21) Specifications

4.1 Performance Specifications

Item	Specification	Item	Specification
Rated load (kg/lbs)	230/510	Turntable rotation by one circle(in the lifted state) (S)	82-92
Vehicle weight (kg/lbs)	7160/15785	Turntable rotation by one circle(in the stowed state) (S)	82-92
Maximum number of people	2	Boom lifting (S)	35-45
Maximum working height (m/ft)	16.09/52.8	Boom lowering (S)	30-40
Maximum platform height (m/ft)	14.09/46.2	Tower boom lifting (S)	25-35
Maximum horizontal extension (m/ft)	7.67/25.2	Tower boom lowering (S)	26-40
Maximum span height (m/ft)	7.56/24.8	Telescopic boom extended (S)	20-30
Vehicle speed (in the telescoped state) (km/h/mpH)	6.1/3.8	Telescopic boom telescoped (S)	20-30
Vehicle speed (in the lifted state) (km/h/mpH)	0.8/0.5	Jib boom lifting (S)	30-50
Vehicle climbing speed(in the telescoped state) (km/h/mpH)	>1.5/>0.9	Jib boom lowering (S)	20-35
Vehicle climbing speed(in the lifted state) (km/h/mpH)	≤0.8/≤0.5	Platform rotation (S)	13-26
Minimum turning radius (inner wheel) (m/ft)	1.94/6.36	Theoretical climbing ability	45%
Minimum turning radius (outer wheel) (m/ft)	4.41/14.47	Maximum manual force(N)	400
Maximum allowable tilt angle	4.5°	Maximum wind speed(m/s/mpH)	12.5/28
Turntable rotate angle (°)	355	Machine tail swing (mm/in)	296/11.7
Secondary boom raise angle (°)	/	Jib boom raise angle (°)	130
Jib boom rotate angle (°)	/	Platform rotate angle (°)	180

4.2 Dimensions

Item	Specification	Item	Specification
Vehicle length (mm/in)	6766/267	Track width (mm/in)	1981.5/78
Vehicle width (mm/in)	2310/91	Wheelbase (mm/in)	2059/81
Vehicle height (mm/in)	2170/86	Ground clearance (in the telescoped state) (mm/in)	360/14
Working platform size (LxW) (mm/in)	1830x760	Tire specification	848×319



Operation and Safety Manual

	72×30	(diameter×width)(mm/in)	33.4×12.6
--	-------	-------------------------	-----------

4.3 Engine

Item	Specifications/Contents	Item	Specifications/Contents
Model	DEUTZ D2.9L4	Rated speed (r/min)	2600
Rated power (kW)	36.4	Maximum torque (N.m)/speed (r/min)	150/1600
Displacement (L)	2.925	Emission standard	EPA T4f

4.4 Drive system

Item	Parameter/Content
Walking reducer	Output torque (N*m) 3500
Rotary reducer	Output torque (N*m) 8729

4.5 Hydraulic system

Item	Parameter/Content	
Walking system	Type	Closed system
	Working pressure (Mpa/psi)	28/4061
	Displacement of pump(ml/r)	46
	Displacement of motor(ml/r)	38
Function system	Type	Open system
	Displacement of pump(ml/r)	11
	Lifting system(Mpa)	Working pressure (Mpa/psi) 23.5/3408
	Rotary system	Working pressure (Mpa/psi) 23.5/3408
	Steering system	Working pressure (Mpa/psi) 23.5/3408

4.6 Electric system

Item	Parameter/Content	
Battery	Model	6-QW-120B
	Output voltage (V)	12
	Capacity (AH)	120(20 hours)
Control system	Voltage (V) 12	

4.7 Oil filling capacity

Item	Parameters
Hydraulic oil (L/gal)	130/34.3
Engine oil (L/gal)	8.5/2.2
Diesel(L/gal)	65/17.2



Operation and Safety Manual

Reducer (L/gal)	0.68*4/0.18*4
Coolant(L/gal)	8.5/2.2

Note: When hydraulic oil and diesel are filled, it is necessary to use the corresponding hydraulic oil and diesel according to operating environment and temperature. Refer to the following tables:

Item	Condition	Oil viscosity brand	Capacity	Remarks
Hydraulic oil(L/gal)	/	Rando MV32	130/34.3	Chevron
Reducer oil×4 (L/gal)	30° C<The lowest temperature	85W/140	0.68/	SAE API 1560 GL-5
	-10° C<The lowest temperature<30° C	85W/90		
	-30° C<The lowest temperature<-10° C	80W/90	0.18	
	The lowest temperature<-30° C	75W		
Engine oil (L/gal)	Working temperature:-20℃~40℃	15W-40	8.5/2.2	API CH-4
	Working temperature:-25℃~30℃	10W-30		
	Working temperature:-30℃~30℃	5W-30		
	Working temperature:-35℃~20℃	0W-20		
Diesel (L/gal)	/	ULSD	65/17.2	EN590 and ASTM D 975
Coolant (L/gal)	/	/	8.5/2.2	/

4.8 Range of motion



Operation and Safety Manual

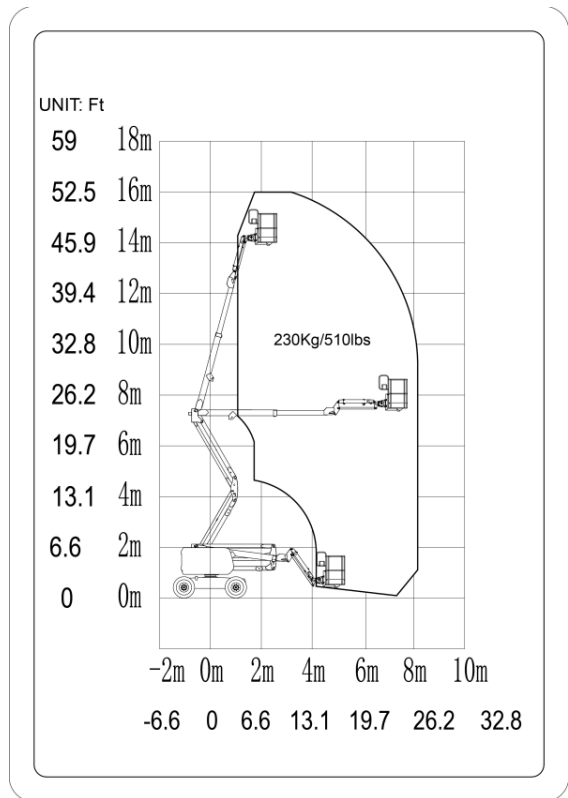



AR45J (A0014JNKAH21) Specifications

4.1 Performance Specifications

Item	Specification	Item	Specification
Rated load (kg/lbs)	230/510	Turntable rotation by one circle(in the lifted state) (S)	82-92
Vehicle weight (kg/lbs)	7160/15785	Turntable rotation by one circle(in the stowed state) (S)	82-92
Maximum number of people	2	Boom lifting (S)	35-45
Maximum working height (m/ft)	16.09/52.8	Boom lowering (S)	30-40
Maximum platform height (m/ft)	14.09/46.2	Tower boom lifting (S)	25-35
Maximum horizontal extension (m/ft)	7.67/25.2	Tower boom lowering (S)	26-40
Maximum span height (m/ft)	7.56/24.8	Telescopic boom extended (S)	20-30
Vehicle speed (in the telescoped state) (km/h/mpH)	6.1/3.8	Telescopic boom telescoped (S)	20-30
Vehicle speed (in the lifted state) (km/h/mpH)	0.8/0.5	Jib boom lifting (S)	30-50
Vehicle climbing speed(in the telescoped state) (km/h/mpH)	>1.5/>0.9	Jib boom lowering (S)	20-35
Vehicle climbing speed(in the lifted state) (km/h/mpH)	≤0.8/≤0.5	Platform rotation (S)	13-26
Minimum turning radius (inner wheel) (m/ft)	1.94/6.36	Theoretical climbing ability	45%
Minimum turning radius (outer wheel) (m/ft)	4.41/14.47	Maximum manual force(N)	400
Maximum allowable tilt angle	4.5°	Maximum wind speed(m/s/mpH)	12.5/28
Turntable rotate angle (°)	355	Machine tail swing (mm/in)	296/11.7
Secondary boom raise angle (°)	/	Jib boom raise angle (°)	130
Jib boom rotate angle (°)	/	Platform rotate angle (°)	180

4.2 Dimensions

Item	Specification	Item	Specification
Vehicle length (mm/in)	6766/267	Track width (mm/in)	1981.5/78
Vehicle width (mm/in)	2310/91	Wheelbase (mm/in)	2059/81
Vehicle height (mm/in)	2170/86	Ground clearance (in the telescoped state) (mm/in)	360/14
Working platform size (LxW) (mm/in)	1830x760	Tire specification	848×319



Operation and Safety Manual

	72×30	(diameter×width)(mm/in)	33.4×12.6
--	-------	-------------------------	-----------

4.3 Engine

Item	Specifications/Contents	Item	Specifications/Contents
Model	V2403-CR-E5B	Rated speed (r/min)	2600
Rated power (KW)	36	Maximum torque (N.m)/speed (r/min)	159.8/1600
Displacement (L)	2.4	Emission standard	EPA T4f

4.4 Drive system

Item	Parameter/Content
Walking reducer	Output torque (N*m) 3500
Rotary reducer	Output torque (N*m) 8729

4.5 Hydraulic system

Item	Parameter/Content		
Walking system	Type	Closed system	
	Working pressure (Mpa/psi)	28/4061	
	Displacement of pump(ml/r)	46	
	Displacement of motor(ml/r)	38	
Function system	Type	Open system	
	Displacement of pump(ml/r)		11
	Lifting system(Mpa)	Working pressure (Mpa/psi)	23.5/3408
	Rotary system	Working pressure (Mpa/psi)	23.5/3408
	Steering system	Working pressure (Mpa/psi)	23.5/3408

4.6 Electric system

Item	Parameter/Content	
Battery	Model	6-QW-120B
	Output voltage (V)	12
	Capacity (AH)	120(20 hours)
Control system	Voltage (V)	12

4.7 Oil filling capacity

Item	Parameters
Hydraulic oil (L/gal)	130/34.3
Engine oil (L/gal)	8/2.1
Diesel(L/gal)	65/17.2



Operation and Safety Manual

Reducer (L/gal)	0.68*4/0.18*4
Coolant(L/gal)	7.5/2

Note: When hydraulic oil and diesel are filled, it is necessary to use the corresponding hydraulic oil and diesel according to operating environment and temperature. Refer to the following tables:

Item	Condition	Oil viscosity brand	Capacity	Remarks
Hydraulic oil(L/gal)	/	Rando MV32	130/34.3	Chevron
Reducer oil×4(L/gal)	30° C<The lowest temperature	85W/140	0.68/0.18	SAE API 1560 GL-5
	-10° C<The lowest temperature<30° C	85W/90		
	-30° C<The lowest temperature< -10° C	80W/90		
	The lowest temperature<-30° C	75W		
Engine oil(L/gal)	Working temperature:-20°C~40°C	15W-40	8/2.1	API CJ-4
	Working temperature:-25°C~30°C	10W-30		
	Working temperature:-30°C~30°C	5W-30		
	Working temperature:-35°C~20°C	0W-20		
Diesel (L/gal)	/	ULSD	65/17.2	EN590 and ASTM D 975
Coolant (L/gal)	/	50% LLC/50% clean soft water	7.5/2	/

4.8 Range of motion



Operation and Safety Manual

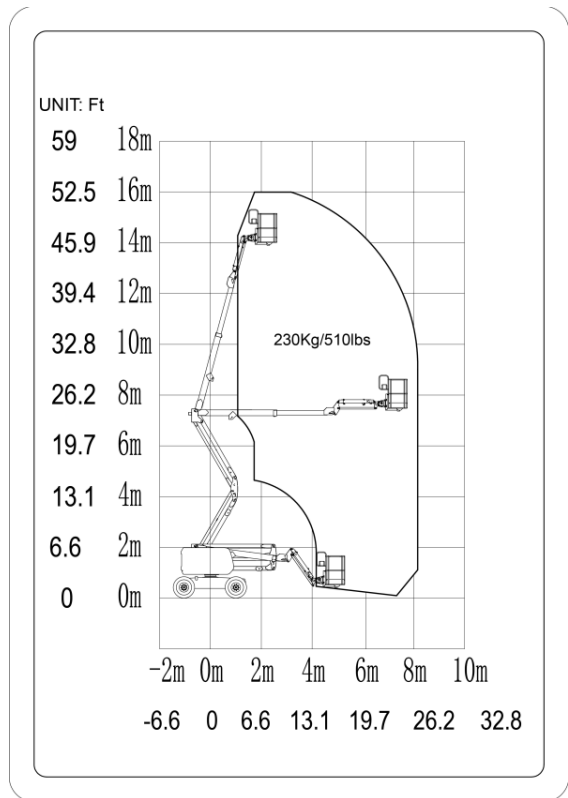



AR45J (A1408J0Wnk3AH2000) Specifications

4.1 Performance Specifications

Item	Specification	Item	Specification
Rated load (kg/lbs)	230/510	Turntable rotation by one circle(in the lifted state) (S)	82-92
Vehicle weight (kg/lbs)	7070/15587	Turntable rotation by one circle(in the stowed state) (S)	82-92
Maximum number of people	2	Boom lifting (S)	35-45
Maximum working height (m/ft)	16.09/52.8	Boom lowering (S)	30-40
Maximum platform height (m/ft)	14.09/46.2	Tower boom lifting (S)	25-35
Maximum horizontal extension (m/ft)	7.67/25.2	Tower boom lowering (S)	26-40
Maximum span height (m/ft)	7.56/24.8	Telescopic boom extended (S)	20-30
Vehicle speed (in the telescoped state) (km/h/mpH)	6.1/3.8	Telescopic boom telescoped (S)	20-30
Vehicle speed (in the lifted state) (km/h/mpH)	0.8/0.5	Jib boom lifting (S)	30-50
Vehicle climbing speed(in the telescoped state) (km/h/mpH)	>2/>1.2	Jib boom lowering (S)	20-35
Vehicle climbing speed(in the lifted state) (km/h/mpH)	≤0.8/≤0.5	Platform rotation (S)	13-26
Minimum turning radius (inner wheel) (m/ft)	1.94/6.36	Theoretical climbing ability	45%
Minimum turning radius (outer wheel) (m/ft)	4.41/14.47	Maximum manual force(N)	400
Maximum allowable tilt angle	4.5°	Maximum wind speed(m/s/mpH)	12.5/28
Turntable rotate angle (°)	355	Machine tail swing (mm/in)	296/11.7
Secondary boom raise angle (°)	/	Jib boom raise angle (°)	130
Jib boom rotate angle (°)	/	Platform rotate angle (°)	180

4.2 Dimensions

Item	Specification	Item	Specification
Vehicle length (mm/in)	6766/267	Track width (mm/in)	1981.5/78
Vehicle width (mm/in)	2310/91	Wheelbase (mm/in)	2059/81
Vehicle height (mm/in)	2170/86	Ground clearance (in the telescoped state) (mm/in)	360/14
Working platform size (LxW) (mm/in)	1830x760	Tire specification	848×319



	72×30	(diameter×width)(mm/in)	33.4×12.6
--	-------	-------------------------	-----------

4.3 Engine

Item	Specifications/Contents	Item	Specifications/Contents
Model	V2403-M-DI-ET04e	Rated speed (r/min)	2600
Rated power (kW)	36	Maximum torque (N.m)/speed (r/min)	156.3/1600
Displacement (L)	2.4	Emission standard	EU Stage IIIA

4.4 Drive system

Item		Parameter/Content
Walking reducer	Output torque (N*m)	3500
Rotary reducer	Output torque (N*m)	8729

4.5 Hydraulic system

Item		Parameter/Content	
Walking system	Type	Closed system	
	Working pressure (Mpa/psi)	28/4061	
	Displacement of pump(ml/r)	46	
	Displacement of motor(ml/r)	38	
Function system	Type	Open system	
	Displacement of pump(ml/r)		11
	Lifting system(Mpa)	Working pressure (Mpa/psi)	23.5/3408
	Rotary system	Working pressure (Mpa/psi)	23.5/3408
	Steering system	Working pressure (Mpa/psi)	23.5/3408

4.6 Electric system

Item		Parameter/Content
Battery	Model	6-QW-120B
	Output voltage (V)	12
	Capacity (AH)	120(20 hours)
Control system	Voltage (V)	12

4.7 Oil filling capacity

Item	Parameters
Hydraulic oil (L/gal)	130/34.3
Engine oil (L/gal)	8/2.1
Diesel(L/gal)	65/17.2



Operation and Safety Manual

Reducer (L/gal)	0.68*4/0.18*4
Coolant(L/gal)	7.5/2

Note: When hydraulic oil and diesel are filled, it is necessary to use the corresponding hydraulic oil and diesel according to operating environment and temperature. Refer to the following tables:

Item	Condition	Oil viscosity brand	Capacity	Remarks
Hydraulic oil(L/gal)	/	Rando MV32	130/34.3	Chevron
Reducer oil × 4(L/gal)	30° C < The lowest temperature	85W/140	0.68/0.18	SAE API 1560 GL-5
	-10° C < The lowest temperature < 30° C	85W/90		
	-30° C < The lowest temperature < -10° C	80W/90		
	The lowest temperature < -30° C	75W		
Engine oil(L/gal)	Working temperature: -20°C ~ 40°C	15W-40	8/2.1	API CH-4
	Working temperature: -25°C ~ 30°C	10W-30		
	Working temperature: -30°C ~ 30°C	5W-30		
	Working temperature: -35°C ~ 20°C	0W-20		
Diesel (L/gal)	/	ULSD	65/17.2	EN590 and ASTM D 975
Coolant (L/gal)	/	50% LLC/50% clean soft water	7.5/2	/

4.8 Range of motion



Operation and Safety Manual

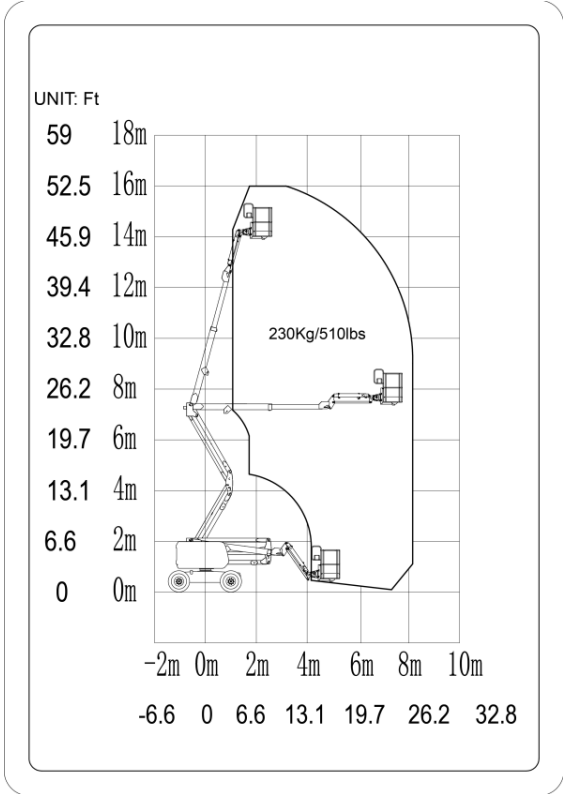



AR52J (A0016JNDAH21) Specifications

4.1 Performance Specifications

Item	Specification	Item	Specification
Rated load (kg/lbs)	230/510	Turntable rotation by one circle(in the lifted state) (S)	82-92
Vehicle weight (kg/lbs)	8180/18034	Turntable rotation by one circle(in the stowed state) (S)	82-92
Maximum number of people	2	Boom lifting (S)	35-45
Maximum working height (m/ft)	17.7/58	Boom lowering (S)	30-40
Maximum platform height (m/ft)	15.7/52	Tower boom lifting (S)	25-35
Maximum horizontal extension (m/ft)	9.39/30.8	Tower boom lowering (S)	26-40
Maximum span height (m/ft)	7.56/24.8	Telescopic boom extended(S)	20-30
Vehicle speed (in the telescoped state) (km/h/mpH)	6.1/3.8	Telescopic boom telescoped (S)	20-30
Vehicle speed (in the lifted state) (km/h/mpH)	0.8/0.5	Jib boom lifting (S)	30-50
Vehicle climbing speed(in the telescoped state) (km/h/mpH)	>1.5/>0.9	Jib boom lowering (S)	20-35
Vehicle climbing speed(in the lifted state) (km/h/mpH)	≤0.8/≤0.5	Platform rotation (S)	13-26
Minimum turning radius (inner wheel) (m/ft)	1.94/6.36	Theoretical climbing ability	45%
Minimum turning radius (outer wheel) (m/ft)	4.41/14.47	Maximum manual force(N)	400
Maximum allowable tilt angle	4.5°	Maximum wind speed(m/s/mpH)	12.5/28
Turntable rotate angle (°)	355	Machine tail swing (mm/in)	0
Secondary boom raise angle (°)	/	Jib boom raise angle (°)	130
Jib boom rotate angle (°)	/	Platform rotate angle (°)	180

4.2 Dimensions

Item	Specification	Item	Specification
Vehicle length (mm/in)	7560/298	Track width (mm/in)	1981.5/78
Vehicle width (mm/in)	2310/91	Wheelbase (mm/in)	2059/81
Vehicle height (mm/in)	2170/86	Ground clearance (in the telescoped state) (mm/in)	360/14
Working platform size (LxW) (mm/in)	1830x760	Tire specification	848×319



Operation and Safety Manual

	72×30	(diameter×width)(mm/in)	33.4×12.6
--	-------	-------------------------	-----------

4.3 Engine

Item	Specifications/Contents	Item	Specifications/Contents
Model	DEUTZ D2.9L4	Rated speed (r/min)	2600
Rated power (kW)	36.4	Maximum torque (N.m)/speed (r/min)	150/1600
Displacement (L)	2.925	Emission standard	EPA T4f

4.4 Drive system

Item	Parameter/Content
Walking reducer	Output torque (N*m) 3500
Rotary reducer	Output torque (N*m) 8729

4.5 Hydraulic system

Item	Parameter/Content	
Walking system	Type	Closed system
	Working pressure (Mpa/psi)	28/4061
	Displacement of pump(ml/r)	46
	Displacement of motor(ml/r)	38
Function system	Type	Open system
	Displacement of pump(ml/r)	11
	Lifting system(Mpa)	Working pressure (Mpa/psi) 23.5/3408
	Rotary system	Working pressure (Mpa/psi) 23.5/3408
	Steering system	Working pressure (Mpa/psi) 23.5/3408

4.6 Electric system

Item	Parameter/Content	
Battery	Model	6-QW-120B
	Output voltage (V)	12
	Capacity (AH)	120(20 hours)
Control system	Voltage (V)	12

4.7 Oil filling capacity

Item	Parameters
Hydraulic oil (L/gal)	130/34.3
Engine oil (L/gal)	8.5/2.2



Operation and Safety Manual

Diesel(L/gal)	65/17.2
Reducer (L/gal)	0.68*4/0.18*4
Coolant(L/gal)	8.5/2.2

Note: When hydraulic oil and diesel are filled, it is necessary to use the corresponding hydraulic oil and diesel according to operating environment and temperature. Refer to the following tables:

Item	Condition	Oil viscosity brand	Capacity	Remarks
Hydraulic oil(L)	/	Rando MV32	130/34.3	Chevron
Reducer oil×4(L)	30° C<The lowest temperature	85W/140	0.18*4	SAE API 1560 GL-5
	-10° C<The lowest temperature<30° C	85W/90		
	-30° C<The lowest temperature<-10° C	80W/90		
	The lowest temperature<-30° C	75W		
Engine oil(L)	Working temperature:-20°C~40°C	15W-40	8.5/2.2	API CH-4
	Working temperature:-25°C~30°C	10W-30		
	Working temperature:-30°C~30°C	5W-30		
	Working temperature:-35°C~20°C	0W-20		
Diesel(L/gal)	/	ULSD	65/17.2	EN590 and ASTM D 975
Coolant(L/gal)	/	/	8.5/2.2	/

4.8 Range of motion



Operation and Safety Manual

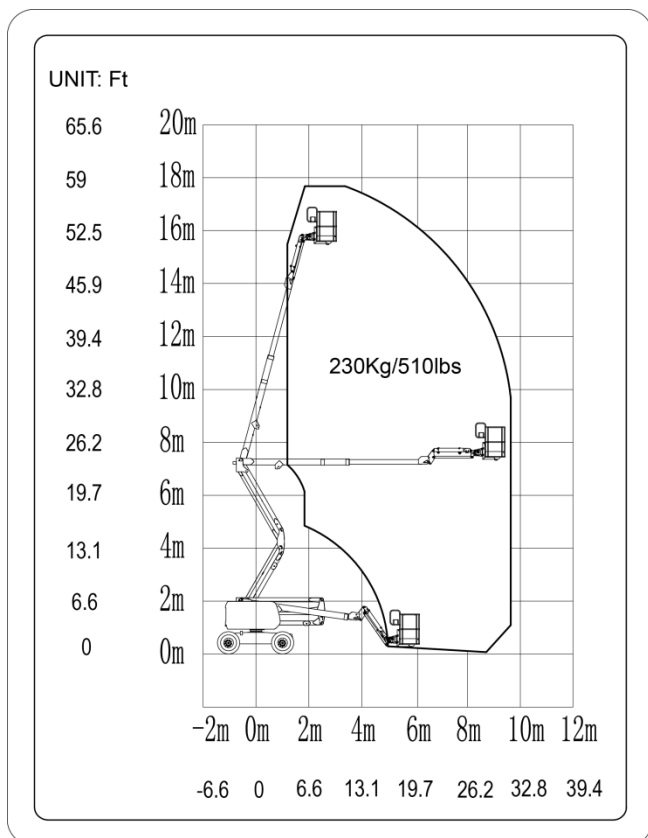



AR52J (A0016JNKAH21) Specifications

4.1 Performance Specifications

Item	Specification	Item	Specification
Rated load (kg/lbs)	230/510	Turntable rotation by one circle(in the lifted state) (S)	82-92
Vehicle weight (kg/lbs)	8180/18034	Turntable rotation by one circle(in the stowed state) (S)	82-92
Maximum number of people	2	Boom lifting (S)	35-45
Maximum working height (m/ft)	17.7/58	Boom lowering (S)	30-40
Maximum platform height (m/ft)	15.7/52	Tower boom lifting (S)	25-35
Maximum horizontal extension (m/ft)	9.39/30.8	Tower boom lowering (S)	26-40
Maximum span height (m/ft)	7.56/24.8	Telescopic boom extended(S)	20-30
Vehicle speed (in the telescoped state) (km/h/mpH)	6.1/3.8	Telescopic boom telescoped (S)	20-30
Vehicle speed (in the lifted state) (km/h/mpH)	0.8/0.5	Jib boom lifting (S)	30-50
Vehicle climbing speed(in the telescoped state) (km/h/mpH)	>1.5/>0.9	Jib boom lowering (S)	20-35
Vehicle climbing speed(in the lifted state) (km/h/mpH)	≤0.8/≤0.5	Platform rotation (S)	13-26
Minimum turning radius (inner wheel) (m/ft)	1.94/6.36	Theoretical climbing ability	45%
Minimum turning radius (outer wheel) (m/ft)	4.41/14.47	Maximum manual force(N)	400
Maximum allowable tilt angle	4.5°	Maximum wind speed(m/s/mpH)	12.5/28
Turntable rotate angle (°)	355	Machine tail swing (mm/in)	0
Secondary boom raise angle (°)	/	Jib boom raise angle (°)	130
Jib boom rotate angle (°)	/	Platform rotate angle (°)	180

4.2 Dimensions

Item	Specification	Item	Specification
Vehicle length (mm/in)	7560/298	Track width (mm/in)	1981.5/78
Vehicle width (mm/in)	2310/91	Wheelbase (mm/in)	2059/81
Vehicle height (mm/in)	2170/86	Ground clearance (in the telescoped state) (mm/in)	360/14
Working platform size (LxW) (mm/in)	1830x760	Tire specification	848×319



Operation and Safety Manual

	72×30	(diameter×width)(mm/in)	33.4×12.6
--	-------	-------------------------	-----------

4.3 Engine

Item	Specifications/Contents	Item	Specifications/Contents
Model	V2403-CR-E5B	Rated speed (r/min)	2600
Rated power (kW)	36	Maximum torque (N.m)/speed (r/min)	159.8/1600
Displacement (L)	2.4	Emission standard	EPA T4f

4.4 Drive system

Item		Parameter/Content
Walking reducer	Output torque (N*m)	3500
Rotary reducer	Output torque (N*m)	8729

4.5 Hydraulic system

Item		Parameter/Content	
Walking system	Type	Closed system	
	Working pressure (Mpa/psi)	28/4061	
	Displacement of pump(ml/r)	46	
	Displacement of motor(ml/r)	38	
Function system	Type	Open system	
	Displacement of pump(ml/r)		11
	Lifting system(Mpa)	Working pressure (Mpa/psi)	23.5/3408
	Rotary system	Working pressure (Mpa/psi)	23.5/3408
	Steering system	Working pressure (Mpa/psi)	23.5/3408

4.6 Electric system

Item		Parameter/Content
Battery	Model	6-QW-120B
	Output voltage (V)	12
	Capacity (AH)	120(20 hours)
Control system	Voltage (V)	12

4.7 Oil filling capacity

Item	Parameters
Hydraulic oil (L/gal)	130/34.3
Engine oil (L/gal)	8/2.1
Diesel(L/gal)	65/17.2



Operation and Safety Manual

Reducer (L/gal)	0.68*4/0.18*4
Coolant(L/gal)	7.5/2

Note: When hydraulic oil and diesel are filled, it is necessary to use the corresponding hydraulic oil and diesel according to operating environment and temperature. Refer to the following tables:

Item	Condition	Oil viscosity brand	Capacity	Remarks
Hydraulic oil(L)	/	Rando MV32	130/34.3	Chevron
Reducer oil×4(L)	30° C<The lowest temperature	85W/140	0.68*4/ 0.18*4	SAE API 1560 GL-5
	-10° C<The lowest temperature<30° C	85W/90		
	-30° C<The lowest temperature<-10° C	80W/90		
	The lowest temperature<-30° C	75W		
Engine oil(L)	Working temperature:-20°C~40°C	15W-40	8/2.1	API CJ-4
	Working temperature:-25°C~30°C	10W-30		
	Working temperature:-30°C~30°C	5W-30		
	Working temperature:-35°C~20°C	0W-20		
Diesel(L/gal)	/	ULSD	65/17.2	EN590 and ASTM D 975
Coolant(L/gal)	/	50% LLC/50% clean soft water	7.5/2	/

4.8 Range of motion



Operation and Safety Manual

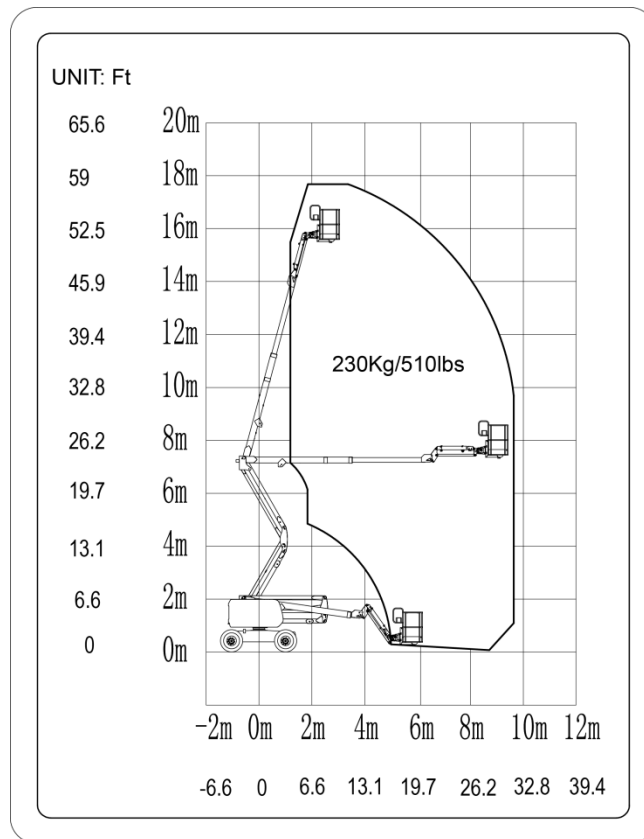



AR52J (A1609J0Wnk3AH2000) Specifications

4.1 Performance Specifications

Item	Specification	Item	Specification
Rated load (kg/lbs)	230/510	Turntable rotation by one circle(in the lifted state) (S)	82-92
Vehicle weight (kg/lbs)	8180/18034	Turntable rotation by one circle(in the stowed state) (S)	82-92
Maximum number of people	2	Boom lifting (S)	35-45
Maximum working height (m/ft)	17.7/58	Boom lowering (S)	30-40
Maximum platform height (m/ft)	15.7/52	Tower boom lifting (S)	25-35
Maximum horizontal extension (m/ft)	9.39/30.8	Tower boom lowering (S)	26-40
Maximum span height (m/ft)	7.56/24.8	Telescopic boom extended(S)	20-30
Vehicle speed (in the telescoped state) (km/h/mpH)	6.1/3.8	Telescopic boom telescoped (S)	20-30
Vehicle speed (in the lifted state) (km/h/mpH)	0.8/0.5	Jib boom lifting (S)	30-50
Vehicle climbing speed(in the telescoped state) (km/h/mpH)	>1.5/>0.9	Jib boom lowering (S)	20-35
Vehicle climbing speed(in the lifted state) (km/h/mpH)	≤0.8/≤0.5	Platform rotation (S)	13-26
Minimum turning radius (inner wheel) (m/ft)	1.94/6.36	Theoretical climbing ability	45%
Minimum turning radius (outer wheel) (m/ft)	4.41/14.47	Maximum manual force(N)	400
Maximum allowable tilt angle	4.5°	Maximum wind speed(m/s/mpH)	12.5/28
Turntable rotate angle (°)	355	Machine tail swing (mm/in)	0
Secondary boom raise angle (°)	/	Jib boom raise angle (°)	130
Jib boom rotate angle (°)	/	Platform rotate angle (°)	180

4.2 Dimensions

Item	Specification	Item	Specification
Vehicle length (mm/in)	7560/298	Track width (mm/in)	1981.5/78
Vehicle width (mm/in)	2310/91	Wheelbase (mm/in)	2059/81
Vehicle height (mm/in)	2170/86	Ground clearance (in the telescoped state) (mm/in)	360/14



Working platform size (LxW) (mm/in)	1830x760 72x30	Tire specification (diameter x width)(mm/in)	848 x 319 33.4 x 12.6
----------------------------------------	-------------------	-------------------------------------------------	--------------------------

4.3 Engine

Item	Specifications/Contents	Item	Specifications/Contents
Model	V2403-M-DI-ET04e	Rated speed (r/min)	2600
Rated power (kW)	36	Maximum torque (N.m)/speed (r/min)	156.3/1600
Displacement (L)	2.4	Emission standard	EU Stage IIIA

4.4 Drive system

Item		Parameter/Content
Walking reducer	Output torque (N*m)	3500
Rotary reducer	Output torque (N*m)	8729

4.5 Hydraulic system

Item		Parameter/Content	
Walking system	Type	Closed system	
	Working pressure (Mpa/psi)	28/4061	
	Displacement of pump(ml/r)	46	
	Displacement of motor(ml/r)	38	
Function system	Type	Open system	
	Displacement of pump(ml/r)		11
	Lifting system(Mpa)	Working pressure (Mpa/psi)	23.5/3408
	Rotary system	Working pressure (Mpa/psi)	23.5/3408
	Steering system	Working pressure (Mpa/psi)	23.5/3408

4.6 Electric system

Item	Parameter/Content
------	-------------------



Battery	Model	6-QW-120B
	Output voltage (V)	12
	Capacity (AH)	120(20 hours)
Control system	Voltage (V)	12

4.7 Oil filling capacity

Item	Parameters
Hydraulic oil (L/gal)	130/34.3
Engine oil (L/gal)	8/2.1
Diesel(L/gal)	65/17.2
Reducer (L/gal)	0.68*4/0.18*4
Coolant(L/gal)	7.5/2

Note: When hydraulic oil and diesel are filled, it is necessary to use the corresponding hydraulic oil and diesel according to operating environment and temperature. Refer to the following tables:

Item	Condition	Oil viscosity brand	Capacity	Remarks
Hydraulic oil(L)	/	Rando MV32	130/34.3	Chevron
Reducer oil×4(L)	30° C<The lowest temperature	85W/140	0.68*4/ 0.18*4	SAE API 1560 GL-5
	-10° C<The lowest temperature< 30° C	85W/90		
	-30° C<The lowest temperature< -10° C	80W/90		
	The lowest temperature<-30° C	75W		
Engine oil(L)	Working temperature:-20℃~40℃	15W-40	8/2.1	API CH-4
	Working temperature:-25℃~30℃	10W-30		
	Working temperature:-30℃~30℃	5W-30		
	Working temperature:-35℃~20℃	0W-20		
Diesel(L/gal)	/	ULSD	65/17.2	EN590



				and ASTM D 975
Coolant(L/gal)	/	50% LLC/50% clean soft water	7.5/2	/

4.8 Range of motion

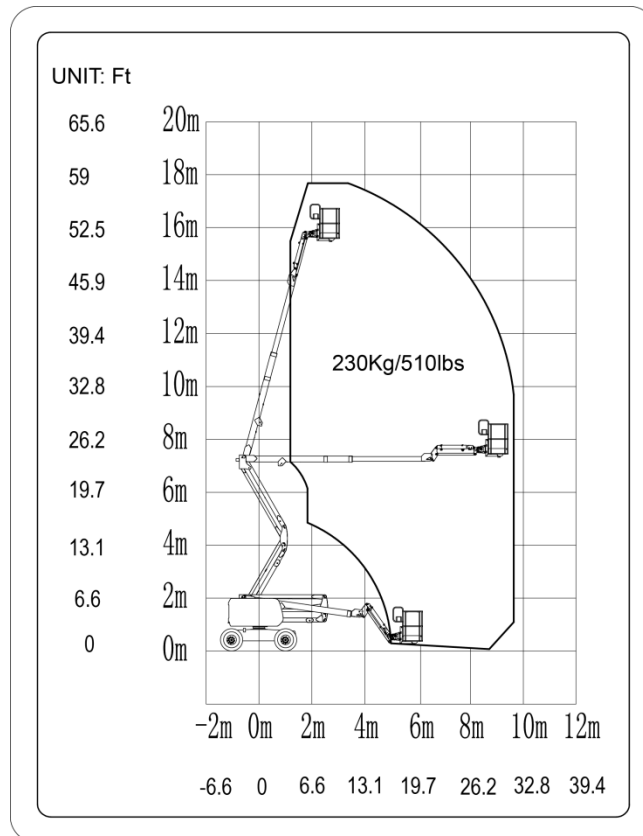



Chapter 5 Control Unit





5.1 Lower Control Box

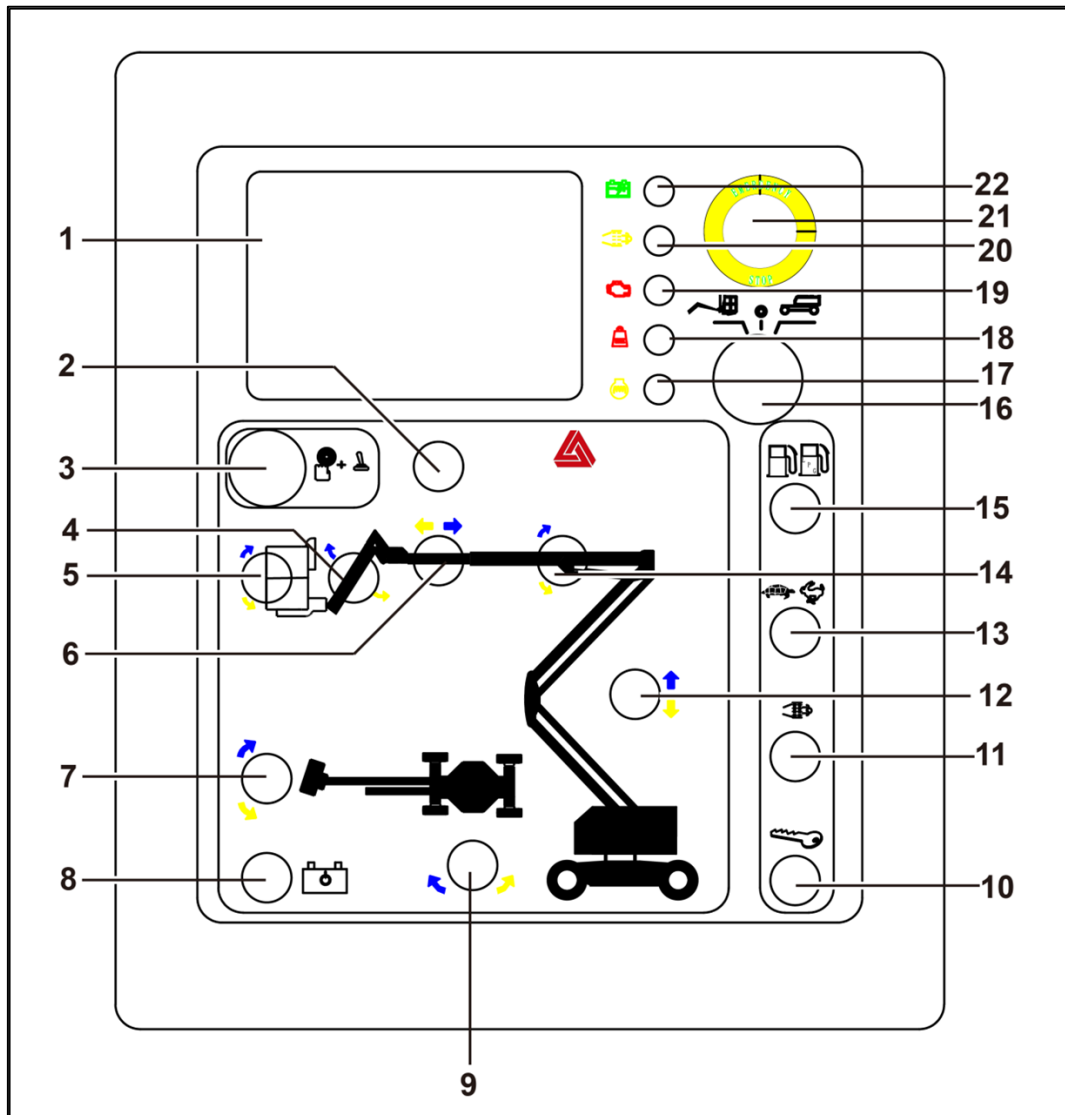

(If equipped)

No.	Name	No.	Name
1	Display	12	Tower Boom Up/Down Switch
2	Self-Resetting Fuse For Controlling Circuit	13	Engine Idle Speed (Rpm) Selector Switch
3	Function Enable Switch	14	Base Boom Up/Down Switch
4	Jib Boom Up/Down Switch	15	Reserve
5	Platform Leveling Switch	16	Key Switch



Operation and Safety Manual

6	Base boom Extend/Retract Switch	17	Engine Warm Up Indicator
7	Platform Swing Button	18	Platform Overweight Alarm
8	Emergency Power Unit Switch	19	Engine Failure Alarm
9	Turntable Rotation Switch	20	Regeneration Indicator (If equipped)
10	Engine Start Switch	21	Emergency Stop Button Switch
11	Manual DPF regeneration switch (If equipped)	22	Power on Indicator

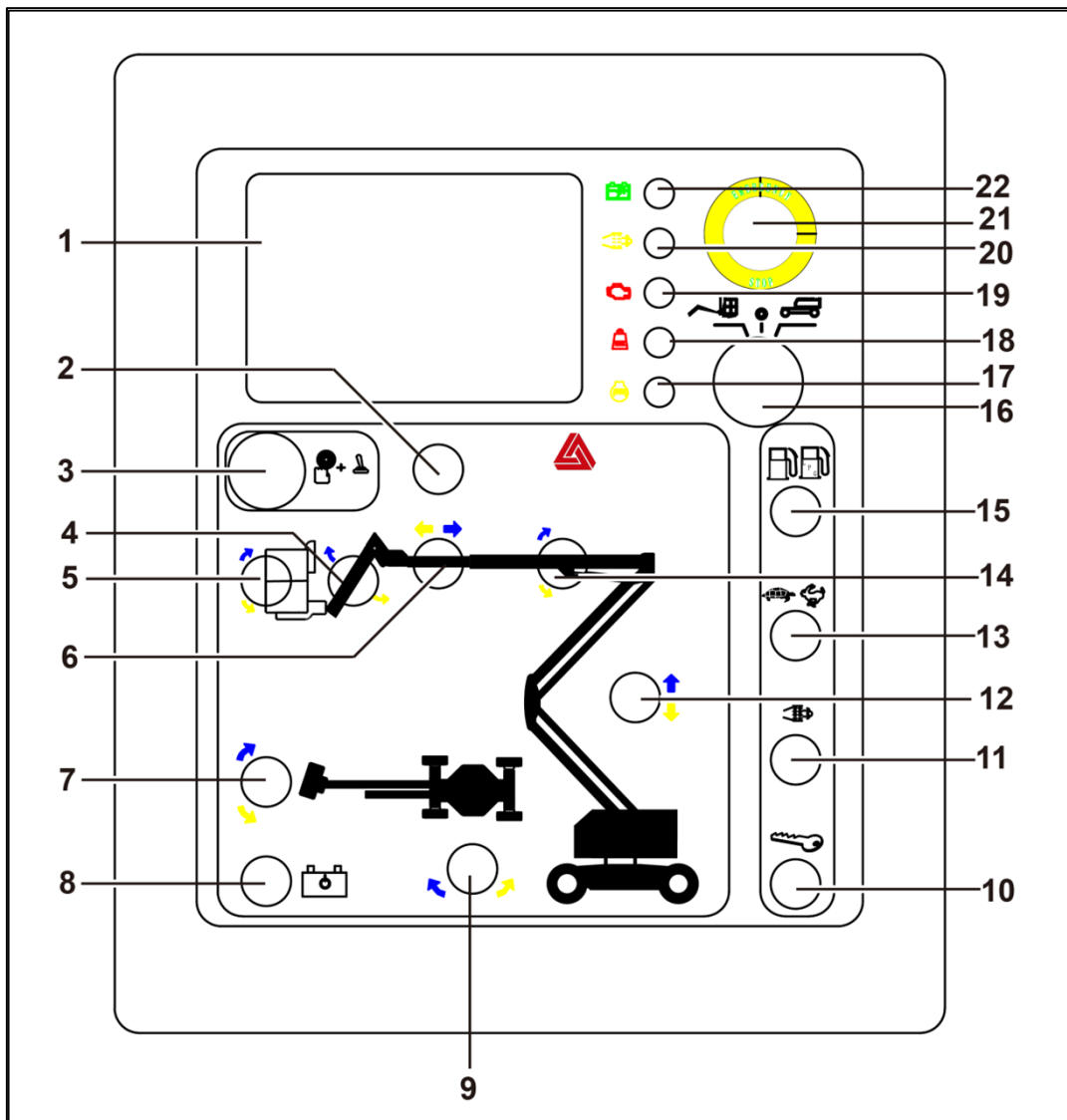

(If equipped)

No.	Name	No.	Name
1	Display	12	Tower Boom Up/Down Switch
2	Self-Resetting Fuse For Controlling Circuit	13	Engine Idle Speed (Rpm) Selector Switch
3	Function Enable Switch	14	Base Boom Up/Down Switch
4	Jib Boom Up/Down Switch	15	Reserve
5	Platform Leveling Switch	16	Key Switch



Operation and Safety Manual

6	Base boom Extend/Retract Switch	17	Engine Warm Up Indicator
7	Platform Swing Button	18	Platform Overweight Alarm
8	Emergency Power Unit Switch	19	Engine Failure Alarm
9	Turntable Rotation Switch	20	Parked Regeneration Request Indicator
10	Engine Start Switch	21	Emergency Stop Button Switch
11	Manual DPF regeneration switch	22	Active Regeneration Indicator

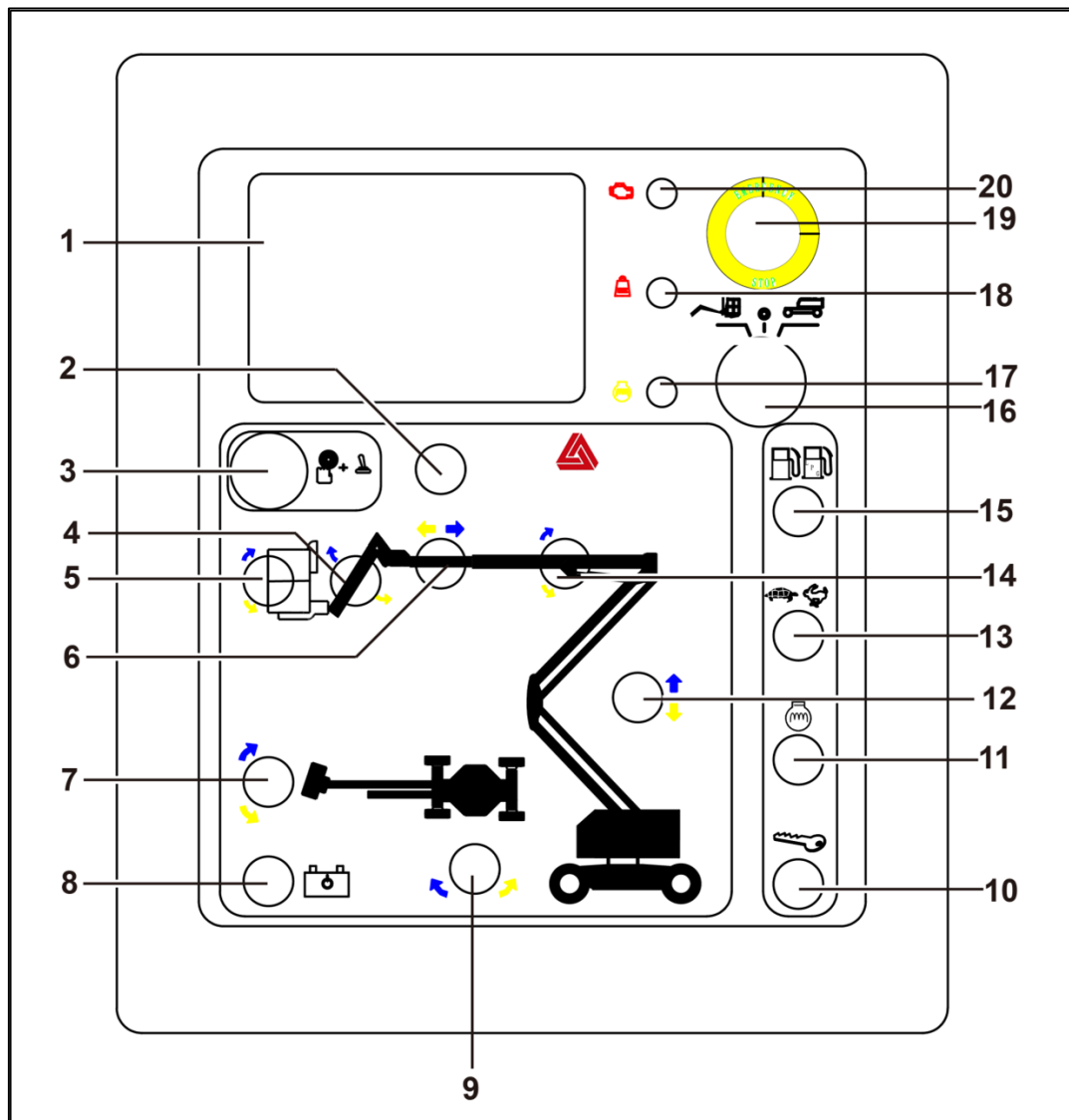



(If equipped)





No.	Name	No.	Name
1	Display	11	Reserve
2	Self-Resetting Fuse For Controlling Circuit	12	Tower Boom Up/Down Switch
3	Function Enable Switch	13	Engine Idle Speed (Rpm) Selector Switch
4	Jib Boom Up/Down Switch	14	Base Boom Up/Down Switch
5	Platform Leveling Switch	15	Reserve
6	Base boom extend/retract Switch	16	Key Switch
7	Platform Swing Button	17	Engine Warm Up Indicator
8	Emergency Power Unit Switch	18	Platform Overweight Alarm
9	Turntable Rotation Switch	19	Emergency Stop Button Switch
10	Engine Start Switch	20	Engine Failure Alarm



Item	Button switch	Functional description
------	---------------	------------------------



The functional description of the lower control box button switch is as follows:



Lower Control Box	Key Switch	When turning the key switch to the “Platform” position, the upper control box will be enabled. When turning the key switch to the “OFF” position, the vehicle will stop. Turn the key switch to the “Ground” position and the lower control box will be enabled.
	Emergency Stop Button Switch	When pushing the red “Emergency Stop” button inward to the “OFF” position, all functions can be disabled. When each function control handle or button switch of the vehicle is enabled, all functions will not be enabled.
		When pulling the red “Emergency Stop” button to the “ON” position, the vehicle can be operated and the warning light should flash.
	Function Enable Switch	Do not press and hold the function enable switch, try to activate each boom and platform function button switch. The boom and platform functions will not be enabled.
		When pressing and holding the function enable button and activating each boom and platform function button switch, the boom and platform functions should operate for a full cycle.
	Engine Start Switch	Move the engine start switch to one side to start the engine.
	Emergency Lowering Switch	Use emergency power if the primary power source (engine) fails. Simultaneously hold the emergency power switch to upper side and activate the desired function.
	<ol style="list-style-type: none"> 1. Turn the key button switch to the lower control box. 2. Pull the red “Emergency Stop” button outward to the “ON” position. 3. Press and hold the enable button. 	
	Platform Swing Switch	 <p>When moving the platform swing button switch to the right, the platform will rotate to the right. When moving the platform rotation button switch to the left, the platform will rotate to the left.</p>
	Turntable Swing Switch	 <p>When turning the button switch to the right, the turntable will move to the right. When moving the button to the left, the turntable will move to the left.</p>
	Base Boom Up/Down Switch	 <p>When pulling the button switch upward, the boom will be lifted. When pulling the button switch downward, the boom will be lowered. The lowering alarm should sound when the boom is lowered.</p>
	Base Boom Extending/Telescoping Switch	 <p>When pulling the button switch to the left, the boom will be extended. When pressing the button switch to the right, the boom will be telescoped.</p>



Operation and Safety Manual

	Tower boom section Up/Down Switch	 <p>When pulling the button switch upward, the tower boom section will be lifted. When pulling the button switch downward, the tower boom section will be lowered. The lowering alarm should sound when the boom is lowered.</p>
	Platform Leveling Switch	 <p>When pulling the platform leveling button switch upward, the level of the platform will rise. When pulling the platform leveling button switch downward, the level of the platform will lower.</p>
	Jib Boom Up/Down Switch	 <p>When pulling the button switch upward, the Jib boom will be lifted. When pulling the button switch downward, the Jib boom will be lowered.</p>



5.2 Upper Control Box

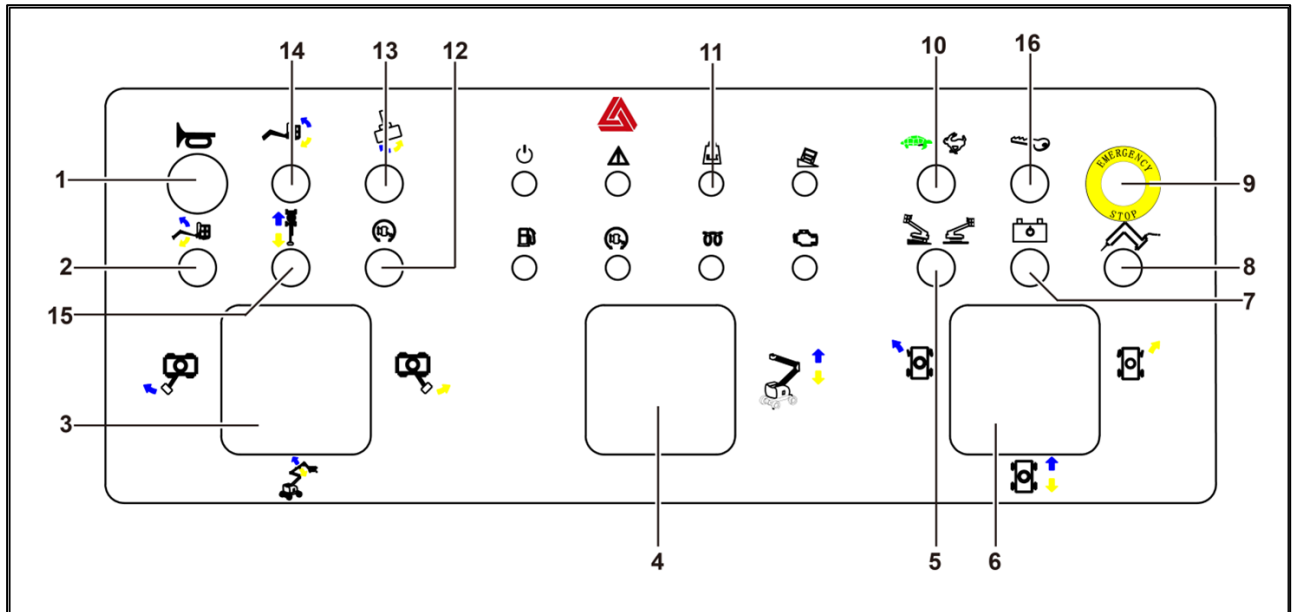

No.	Name	No.	Name
1	Horn Button	9	Emergency Stop Switch
2	Jib Up/Down Button	10	Engine Idle Speed Selector Switch
3	Base Boom Up/Down and Turntable Rotation Switch	11	Indicator
4	Tower Boom Up/Down Switch	12	Drive Enable Button Switch
5	Drive Speed Selector Switch	13	Platform Swing Switch
6	Drive/Steering Control Handle	14	Platform Leveling Switch
7	Emergency Power Unit	15	Base boom Extension and Retraction switch
8	Generator Switch(If equipped)	16	Engine Start switch





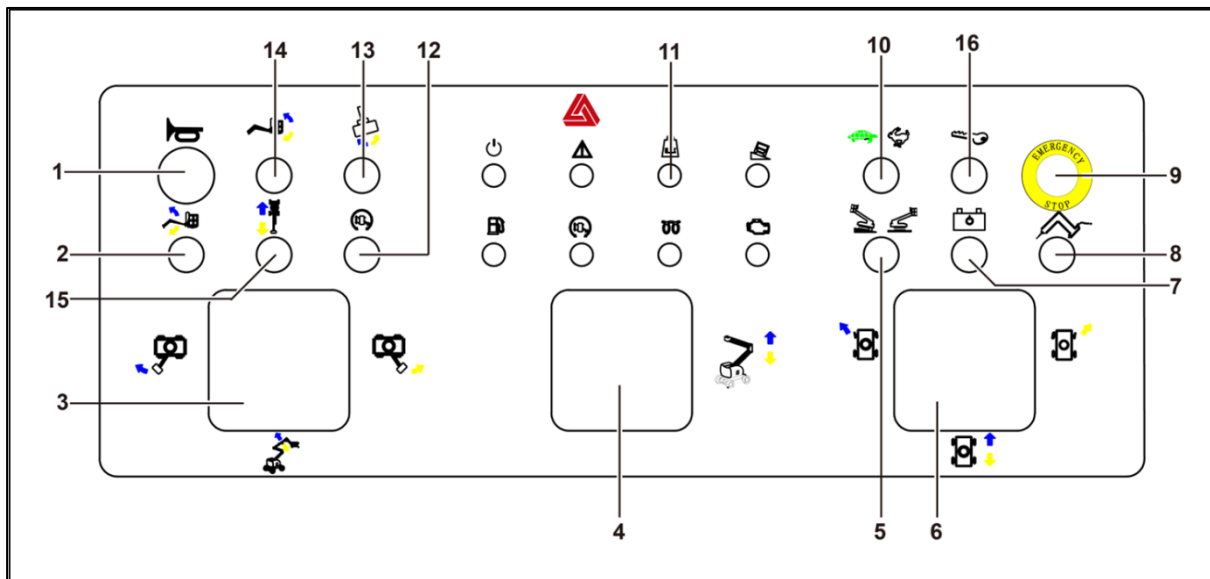





Operation and Safety Manual





(If equipped)

No.	Name	No.	Name
1	Horn Button	9	Emergency Stop Switch
2	Jib Up/Down Button	10	Engine Idle Speed Selector Switch
3	Base Boom Up/Down and Turntable Rotation Switch	11	Indicator
4	Tower Boom Up/Down Switch	12	Drive Enable Button Switch
5	Drive Speed Selector Switch	13	Platform Swing Switch
6	Drive/Steering Control Handle	14	Platform Leveling Switch
7	Emergency Power Unit	15	Base boom Extension and Retraction switch
8	Engine Warm Up Switch	16	Engine Start switch

	Platform overweight alarm		Minimum fuel level alarm
	Drive enabling alarm		System failure alarm
	Machine tilt alarm		Engine failure alarm
	Generator is in use		Glow plugs are on









The functional description of the upper control box button switch is as follows:



Item	Button switch	Functional description	
Upper control box	Emergency Stop Button Switch	When pushing the red “Emergency Stop” button inward to the “OFF” position, all functions can be disabled. When each function control handle or button switch of the vehicle is activated, all functions cannot be enabled.	
		When the red "Emergency Stop" button is pulled to the “ON” position, the vehicle can be operated.	
	Engine Start Switch	Move the engine start switch to one side to start the engine.	
	Foot Switch	The foot button switch may not be pressed and each function of the vehicle should be enabled. As a result, the vehicle function cannot be enabled.	
		When the foot button switch is pressed to activate each function control handle or button switch of the vehicle, all boom and platform functions should operate for a full cycle.	
	Emergency Power Unit Switch	If the main power source (engine) fails, use the emergency power unit. Step on the foot switch to start the required functions while keeping the emergency power switch on.	
	Engine Warm-Up switch	When starting at a low temperature, turn the toggle switch to the other side to warm up the engine, and then pull back the toggle switch to stop warming up.	
	Horn Button	When the horn button is pressed, the horn will sound. When the horn button is released, the horn will stop ringing.	
	1. Turn the key button switch to the upper control box. 2. Pull the red “Emergency Stop” button outward to the “ON” position. 3. Press the foot switch.		
	Platform Swing Switch	 When moving the platform Swing button switch to the right, the platform will rotate to the right. When moving the platform rotation button switch to the left, the platform will rotate to the left.	
Base boom Up/Down/ and Turntable Left/Right Rotation	 When moving the control handle to the right, the turntable will move to the right. When moving the control handle to the left, the turntable will move to the left.		



Operation and Safety Manual

	 <p>When moving the control handle up, the boom will be lifted. When moving the control handle downward, the boom will be lowered. The lowering alarm should sound when the boom is lowered.</p>
Base boom Extend/Retract switch	 <p>Move the switch down and the boom will extend. Move the switch up and the boom will retract.</p>
Tower Boom Section Up/Down Switch	 <p>When pulling the button switch upward, the tower boom section will be lifted. When pulling the button switch downward, the tower boom section will be lowered. The lowering alarm should sound when the boom is lowered.</p>
Jib Up/Down Switch	 <p>When pulling the button switch upward, the Jib will be lifted. When pulling the button switch downward, the Jib will be lowered.</p>
Platform Leveling Switch	 <p>When pulling the platform leveling button switch upward, the platform level will be lifted. When pulling the platform leveling button switch downward, the platform level will drop.</p>
Drive/Steering Control Handle	<p>When moving the control handle upward, the vehicle will drive forward. When moving the control handle downward, the vehicle will drive backward. When pressing the left side of the thumb rocker, the vehicle will turn to the left. When pressing the right side of the thumb rocker, the vehicle will turn to the right.</p>
Drive Enable Switch	 <p>Press the foot switch and lower the boom to the telescoped position. Rotate the turntable until the boom moves over more than one non-steering wheel. As a result, the drive enable indicator should be flashes at any position within the range shown in the figure. When moving the drive control handle to the center position, the drive function will not be enabled. When moving the drive enable button switch to one side and slowly moving the drive control handle away from the center position, the drive function should be enabled.</p> <p>Note: When operating the drive enable system, the vehicle can drive in the opposite direction of drive and steering control handle movement.</p>



	Engine Idle Speed Selector Switch	  Pull the idle speed selector switch to the turtle position, the engine starts the low idle speed; Pull the idle speed selector switch to the rabbit position, step on the foot switch and turn the handle, then the engine starts the high idle speed. After releasing the handle, the engine enters the low idle speed.
--	-----------------------------------	----------------------------------------------------------------------------------------------------------------------------------------------------------------------------------------------------------------------------------------------------------------------------------------------------------------------------------------------------------------------------------------------------------------------------------------------------------------------------------------------

5.3 Control Logic (SPD)

After the SPD is triggered, use the platform controls to operate the machine without using the override function, and all functions cannot operate; use the platform controls to operate the machine with using the override function, and the boom can be lowered and retracted but cannot be raised or extended, the turntable cannot be swung, the jib can be lowered but cannot be raised, the platform cannot be rotated or leveled, and the complete machine can travel and steer. After the SPD is triggered, use the ground controls to operate the machine, and all functions except for the traveling and steering functions can operate. The control logic is shown in the table below.

SPD Activated

Position	Platform	Platform	Ground
Power	Main power	Main power	Main power
Status	NO override	Override	NO override
Primary Up Secondary Up	x	x	√
Primary Down Secondary Down	x	√	√
Primary Extend Secondary Extend	x	x	√
Primary Retract Secondary Retract	x	√	√
Turntable Swing	x	x	√
Jib Up	x	x	√
Jib Down	x	√	√
Platform Rotate	x	x	√
Platform Level Up	x	x	√
Platform Level down	x	x	√
Drive	x	√	—
Steer	x	√	—





Chapter 6 Pre-Operation Inspection





6.1 No Operation Is Allowed

Unless

You have understood and practiced the principles about safe operation of the vehicle in this manual.

- 1) Avoid dangerous situations.
- 2) Always perform a pre-operation inspection. You should understand pre-operation inspection before proceeding with the next step.
- 3) Check the workplace.
- 4) Always perform a pre-use functional test.
- 5) Use the vehicle only for its intended purpose.

6.2 Basic Principles

- 1) It is the operator's responsibility to perform pre-operation inspection and routine maintenance.
- 2) Pre-operation inspection is a very intuitive process that is performed by the operator before each shift. The purpose of the inspection is to determine if there is a significant problem with the vehicle before the operator performs a functional test.
- 3) Pre-operation inspection can also be used to determine if a routine maintenance procedure is necessary. The operator can only perform the routine maintenance items specified in this manual.
- 4) See the checklist on the next page and check each item.
- 5) In the event of any damage or any unauthorized changes different from the normal status, the vehicle should be

marked and prohibited from putting into operation.

- 6) Only qualified authorized service technicians are allowed to maintain the vehicle according to the manufacturer's instructions. After the maintenance is completed, the operator must perform a pre-operation inspection again before continuing the functional test.
- 7) Regular maintenance inspections should be performed by qualified authorized service technicians according to the manufacturer's specifications and the requirements listed in the responsibilities manual.

6.3 Pre-Operation Inspection

- 1) Make sure the manual is complete, easy to read, and stored in the manual box on the platform.
- 2) Make sure all decals are clear, legible, and in the right place. See the label section.
- 3) Check hydraulic oil for leakage and appropriate oil level. fill the oil as needed. See the "Maintenance" section.
- 4) Check the battery fluid for leakage and appropriate liquid level. Add the distilled water as needed. See the "Maintenance" section.
- 5) Check the following parts or areas for damage, improper installation, parts missing or unauthorized changes:
 - Electrical components, wires and cables
 - Valve block, hose, joint, cylinder
 - Hydraulic and fuel tank
 - Drive motor, Swing motor and drive hub



- Boom wear pad
 - Tires and wheels
 - Limit button switch, tilt sensor and horn
 - Nuts, bolts and other fasteners
 - Platform overload components
 - Platform entrance lifting rod
 - Alarm light
 - Platform control handle
 - Engine and parts
- 6) Check the entire vehicle for the followings:
- Crack in a weld or structural member
 - Dent or damage to the vehicle
 - Make sure all structural members and other critical components are complete, and all associated fasteners and pins are in the right position and tightened.
 - After completing the inspection, make sure all compartment covers are properly secured and locked.

6.4 Pre-operation Inspection of Safety Protection Devices (SPD)

- 1) Check the following components for damage, improper installation, loose or missing parts, and unauthorized changes:

- Electrical plugs, wiring and cables
 - Display screen, alarm indicator light, strobes, horn, buzzer
 - Nuts, bolts and other fasteners
 - Platform entrance lever
 - Platform safety protection device
- 2) Check to ensure that all structural components and other critical components of the SPD are intact, and that all relevant fasteners and pins are in correct positions and tightened.
- 3) Check to ensure that there are no foreign objects in the SPD grooves.
- 4) Check that the SPD's function is normal, and the machine can be operated normally via the verification procedures.
- 5) If any unauthorized changes from the factory delivered condition or damages are found, the machine must be tagged out and removed from use.



6.5 Machine inspection diagram

Check each structural securement point on the machine in strict accordance with the illustration. Once a loose, broken or missing bolt or dislodged pin is found, immediately tag the abnormal location and remove the equipment from service. Never operate the malfunctioning equipment.

In addition to the following check points, comprehensively verify: whether any component is loose, broken, cracked or missing and securement is firm; and whether hydraulic lines are excessively worn, broken or leaky and harnesses are broken or damaged. Be sure each function operates properly.

⚠ Remember to check the bottom side of the machine! Failure to do so could cause safety accidents, resulting in equipment damage and personal injury or death.

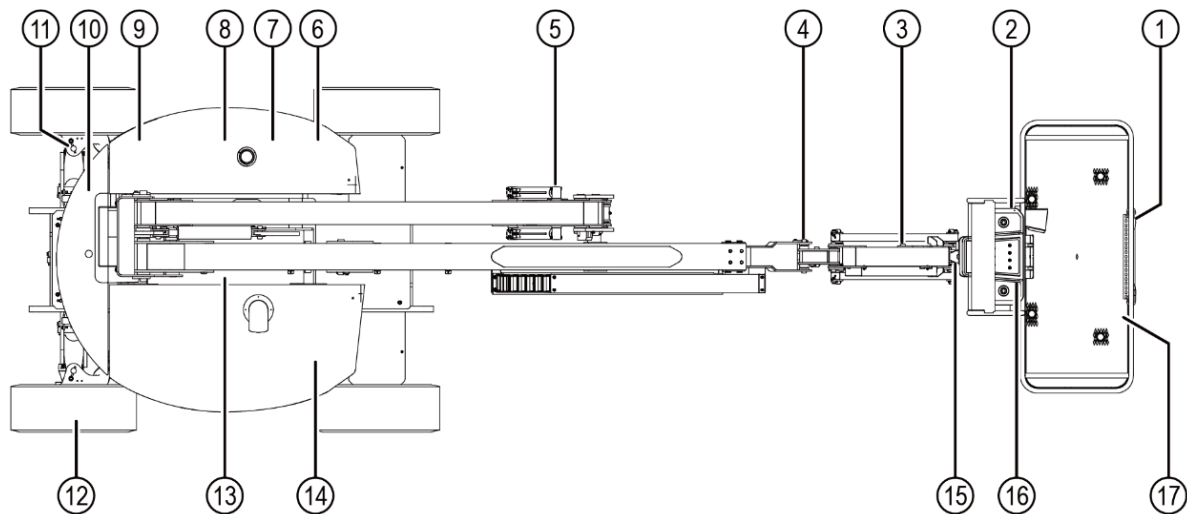

- 1) Securement of gate and sliding midrail with U-bolts: Check the gate lock and hinge and the U-bolts. Use extreme care to prevent personnel fall from the platform due to their malfunction.
- 2) PCU securement: Check bolts for good condition. Use extreme care to prevent PCU dislodgement due to the bolt breakage.
- 3) Cylinder lockout valve securement: Check bolts for good condition. Use extreme care to



prevent unexpected boom fall due to the bolt breakage, which will result in personal fall.

- 4) Boom pin securement: Check bolts for good condition and pins for proper installation. Use extreme care to prevent the boom overturn due to the bolt breakage or pin dislodgement.
- 5) Cylinder securement: Check bolts for good condition and pins for proper installation. Use extreme care to prevent the cylinder fall due to the bolt breakage or pin dislodgement.
- 6) Emergency power unit securement: Check bolts for proper installation. Use extreme care to prevent the emergency power unit dislodgement due to the bolt breakage.
- 7) Hydraulic tank assembly securement: Check bolts for good condition. Use extreme care to prevent the tank fall due to the bolt breakage.
- 8) Directional control valve securement: Check bolts for good condition. Use extreme care to prevent the valve fall due to the bolt breakage.
- 9) Hood assembly securement: Check bolts for proper installation. Use extreme care to prevent the hood fall due to the bolt breakage.
- 10) Counterweight assembly securement: Check bolts for good condition. Use extreme care to prevent the counterweight fall due to the bolt breakage.
- 11) Axle securement: Check bolts for good condition. Use extreme care to prevent the axle separation from the chassis due to the bolt breakage, which will cause the machine to tip over.
- 12) Tire securement: Check nuts for proper tightness. Use extreme care to prevent the tire dislodgement due to the nut looseness.
- 13) Swing mechanism and chassis/turntable securement: Check bolts for good condition. Use extreme care to prevent the chassis/turntable separation from the swing mechanism due to the bolt breakage, which will cause the turntable to overturn.
- 14) Pump securement: Check bolts for good condition. Use extreme care to prevent the pump fall



due to the bolt breakage.

15) Platform rotator securement: Check bolts for good condition. Use extreme care to prevent the platform fall or overturn due to the bolt breakage.

16) Anti-collision bar securement: Check bolts for good condition. Use extreme care to prevent the bar dislodgement due to the bolt breakage.

17) Platform securement: Check bolts for good condition. Use extreme care to prevent the platform separation from its support due to the bolt breakage, which will cause the platform fall or overturn.





Chapter 7 Workplace Inspection





7.1 No Operation Is Allowed Unless

You have understood and practiced the principles about safe operation of the vehicle in this manual.

- 1) Avoid dangerous situations.
- 2) Always perform a pre-operation inspection.
- 3) Check the workplace. You should understand pre-operation inspection before proceeding with the next step.
- 4) Always perform a pre-use functional test.
- 5) Use the vehicle only for its intended purpose.

7.2 Basic Principles

- 1) Workplace inspection will help the operator determine if the workplace is safe for operation of the vehicle. The operator should perform pre-operation inspection before moving the vehicle to the workplace.
- 2) It is the operator's responsibility to understand and remember the hazards in the workplace and to be aware of and avoid these hazards when moving, installing and operating the vehicle.

7.3 Workplace Inspection

Be aware of and avoid the following dangerous situations

- 1) Steep slope or cave
- 2) Protrusions, ground obstacles or debris
- 3) Inclined surface
- 4) Unstable or smooth surface
- 5) Overhead obstacles and high voltage

wires

- 6) Dangerous location
- 7) Surface support that is not sufficient to withstand the full load applied by the vehicle
- 8) Wind and weather conditions
- 9) Unauthorized personnel
- 10) Other possible unsafe conditions





Chapter 8 Functional Test





8.1 No Operation Is Allowed Unless

You have understood and practiced the principles about safe operation of the vehicle in this manual.

- 1) Avoid dangerous situations.
- 2) Always perform a pre-operation inspection.
- 3) Check the workplace.
- 4) Always perform a pre-use functional test.
- 5) You should understand the functional test and inspection before proceeding with the next step.
- 6) Use the vehicle only for its intended purpose.

8.2 Basic Principles

- 1) Functional tests are used to detect faults before operating the vehicle.
- 2) The operator must follow the steps to test all the functions of the vehicle.
- 3) Do not use a malfunctioning vehicle. If a fault is found, the vehicle must be marked and stopped.
- 4) Only qualified authorized service technicians are allowed to maintain the vehicle according to the manufacturer's instructions.
- 5) After maintenance is completed, the operator must perform the pre-operation inspection and functional test again before operating the vehicle.

8.3 Functional Test

- 1) Choose a test place that is solid, level and free of obstacles.

8.4 Tests from the Lower Control Box

- 1) Turn the key button switch to the position of the lower control box.
- 2) Pull out the red "emergency stop" button to the "ON" position, and the warning light will begin to flash.
- 3) Refer to the "Operation Instructions" section to start the engine.

Test of emergency stop

- 1) Push the ground red "Emergency Stop" button inward to the "OFF" position.
- 2) Result: The engine is off and none of the functions work.
- 3) Pull the red emergency stop button to the "on" position to restart the engine.

Test of vehicle function

- 1) Do not press and hold the function enable button switch. Try to enable each boom and platform function button switch.

Result: No boom and platform function can be enabled.

- 2) Press and hold the function enable button and activate each boom and platform function button switch.

Result: The boom and platform functions should operate for a full cycle. When the boom is lowered, the lowering alarm (if equipped) should sound.

Test the Function of the Emergency Power Unit



CAUTION: Perform this step

when the engine is off. In order to save battery energy, test each



function in half a cycle.

- Turn the key switch to the ground control and pull the red emergency stop button out to the "on" position.
- At the same time, press the emergency power unit switch to the on position and start each arm function switch.

Result: All boom functions are operational.

Inspect the Automatic Leveling of the Work Platform

- Start the engine from the ground.
- Press the function enable switch and use the platform leveling toggle switch to adjust the work platform to the horizontal position.
- Raise and descend the boom through a full cycle.

Result: The work platform is always level.

Platform load test

- 1) Lift the load equal to rated load to the center of the platform and raise the platform.

Result: The platform should raise.

- 2) Lift the load 1.2 times of rated load to the center of the platform and raise the platform.

Result: The platform should not raise. The alarm should sound.



NOTICE: If the platform continues to raise upon exceeding the rated load, tag and remove the machine from service.

8.5 Tests from the Upper Control Box

Test the Emergency Stop

- Push the platform red "Emergency Stop" button to the "OFF" position.
- Enter the platform to pull out the red "emergency stop" button and start the engine.
- Push the red "emergency stop" button of the platform to the off position.

Result: The engine is off and no function can be operated.

Test the Horn

- Press the horn button.

Result: The horn sounds.

Test the Foot Switch

- Push the red "emergency stop" button of the platform to the off position.
- Rotate the red "emergency stop" button to the on position and do not start the engine.
- Press down the foot switch and try to start the engine by pulling the start toggle switch to either side.

Result: The engine does not start.

- Do not press the foot switch and restart the engine.

Result: The engine start.

- Do not press the foot switch and test the machine's functions.

Result: None of the functions are running.

Test the Machine Function

- Press down the foot switch.



- Start each function control handle or toggle switch on the machine.

Result: All boom/platform actions work properly in one full cycle.

Test the Emergency Power Function

 **CAUTION: Perform this step**

when the engine is off. In order to save battery energy, test each function in half a cycle.

- Turn the key switch to the work platform control.
- Turn the red emergency stop button to the "on" position on the work platform control and press the foot switch.
- Press the emergency power unit switch to the "on" position and turn on each function control handle or toggle switch.

Result: All arm and steering functions and drive functions do not function.

Test the steering

- Press down the foot switch.
- Press the left side of the thumb stick switch on the top of the drive control handle.
- Press the right side of the thumb stick switch on the top of the drive control handle.

Test the Drive and Brake Function

- Press down the foot switch.
- Move slowly the drive control handle forward until the machine begins to move, and then return the handle to the center position.

Result: The machine stopped suddenly.

- Move slowly the drive control handle backward until the machine begins to move, and then return the handle to the center position.

Result: The machine stopped suddenly.

 **CAUTION: The brakes must be able to stop the machine on any slope that it can climb.**

Test the Tilt Angle Sensor

- Start the engine and drive the machine to a certain slope, then make the turntable tilt 4.5° along the direction of the boom.

Result: The alarm on the platform sounds.

- Drive the machine to a certain slope, and then make the machine tilt 4.5° degrees at a right angle to the boom.

Result: The alarm on the platform sounds.

- Drive the machine to a certain slope to make the alarm sound.
- Start all boom functions in succession.
- Operate the handle to start the turntable Swing function.

Result: After raising the main arm to a 0.9m/2.9ft, it cannot continue to change amplitude up wards. After raising the tower boom section to a 0.9m/2.9ft, it cannot continue to change amplitude up wards. The base boom section cannot continue to extend after an extension of 0.6m/2ft. The rest of the boom functions can be used normally, the turntable cannot be rotated.

 **CAUTION: If the turntable tilts**

4.5° along the direction of the boom or 4.5° along the vertical direction of



the boom, the main arm or the tower boom section can be raised more than 0.9m/2.9ft, or the base boom section can extend more than 0.6 m/2ft. The machine should be marked immediately and stopped using.

Test the Axle Oscillation Cylinder

- Lower the platform to the stowed position.
- Start the engine on the platform.
- Drive the right steering wheel to a 10cm/3.9in high obstacle or curb.

Result: The other three tires are in close contact with the ground.

- Drive the left steering wheel to a 10cm/3.9in high obstacle or curb.

Result: The other three tires are in close contact with the ground.

- Drive the left rear wheel to a 10cm/3.9in high obstacle or curb.

Result: The other three tires are in close contact with the ground.

- Drive the right rear wheel to a 10cm/3.9in high obstacle or curb.

Result: The other three tires are in close contact with the ground.

Test the Drive Enabling System



Figure 8-1 Drive enabling

- Press down the foot switch and lower the boom to the retracted state.

- Rotate the turntable until the boom is turned to a certain angle, as shown in Figure 8-1.

Result: The drive enabling indicator should be flashes when the boom is at any position within the range shown.

- Move the drive control handle away from the center position.

Result: The drive function does not work.

- Move the drive enabling toggle switch to the upper side while slowly moving the drive controller handle away from the center position.

Result: The drive function can be operated.



CAUTION: When using the drive enabling system, the machine may travel in the opposite direction of travel and steering control handle movement. Use the color-coded direction arrows on the drive chassis to determine the direction of movement.

Test the Limited Drive Speed

- Press down the foot switch.
- Raise the base boom section 0.9m/3ft.
- Move slowly the drive control handle to the full drive position.

Result: When the base boom section is lifted, the maximum drive speed that can be achieved does not exceed 0.8km/h/0.5mph.

- Lower the base boom section to the retracted state
- Raise the folding boom 0.9m/3ft.
- Move slowly the drive control handle to the full drive position.



Result: When the folding boom is in the extended state, the maximum drive speed that can be achieved does not exceed 0.8km/h/0.5mph.

- Descend the folding boom to the retracted state
- Extend the base boom section by about 0.6m/2ft.
- Move slowly the drive control handle to the full drive position.

Result: When the boom is in the extended state, the maximum drive speed that can be achieved does not exceed 0.8km/h/0.5mph.



CAUTION: If the drive speed of the boom when it is raised or extended exceeds 0.8km/h/0.5mph, the machine should be tagged out immediately and stopped.



CAUTION: If the time it takes the boom to rotate for a circle in the extended state is less than 82s, the machine should be marked immediately and stopped.

Test the Drive/Boom Function

- Press down the foot switch.
- Move the drive control handle away from the center position and start a boom function handle or toggle switch.

Result: Most boom functions should be operational. The machine moves in the direction indicated on the control panel.





Chapter 9 Operating Instructions





9.1 No Operation is Allowed Unless

You have understood and practiced the principles about safe operation of the machine in this manual.

- 1) Avoid dangerous situations.
- 2) Always perform a pre-operation inspection.
- 3) Check the workplace.
- 4) Always perform a pre-use functional test.
- 5) Use the machine only for its intended purpose.

9.2 Basic Principles

- 1) The vehicle is a self-propelled hydraulic drive lifting device which is equipped with a working platform on an articulating boom mechanism. The vibration generated when the vehicle is running will not be dangerous to the operator who stands on the work platform. The vehicle can be used to load workers and their portable tools to a certain height from the ground, or to reach a certain working area above the vehicle or equipment.
- 2) The Operating Instructions section provides specific instructions for all aspects of vehicle operation. It is the operator's responsibility to follow all safety rules and instructions in this manual.
- 3) This machine is designed for lifting workers and tools to the overhead workplace, it is unsafe or even dangerous to use the vehicle for other purposes.



CAUTION: This vehicle is strictly prohibited from carrying loads.

- 4) Only trained and authorized personnel can operate the vehicle. If more than one operator uses the same vehicle at different times during the same work shift, they must be qualified operators and follow all safety rules and instructions in the Operation and Maintenance Manual. This means that every new operator should perform pre-operation inspections, functional tests and workplace inspections before operating the vehicle.

9.3 Starting the Engine

- 1) From the ground control station, turn the key switch to the required position
- 2) Ensure red "Emergency Shutdown" buttons on the lower control box and the upper control box are pulled to the ON position.
- 3) The engine can be automatically preheated at low temperatures when the whole vehicle is powered on.
- 4) If the primary preheating cannot meet the requirements, press the emergency stop switch of ground control unit and then pull it out, and then perform the preheating operation again.
- 5) Turn the engine startup switch to one side for 2s to 3s. If the engine fails to start or starts up and then stalls immediately, disenable the startup switch for 3s.
- 6) If the engine fails to start 15s, diagnose the reason and repair the fault. Wait for 60s before trying to restart the engine.
- 7) Before operation, the engine shall be



idled for 5 minutes to ensure it sufficiently lubricated in case of hydraulic system damage.

- 8) At temperatures lower than -18°C , a boosting battery may be used to try and start the engine.



CAUTION: Upon the normal running of the engine, do not start up again.

9.4 Emergency Stop

- 1) Push the red emergency shutdown button on the ground or upper control box to the "OFF" position to stop all functions and shut down the engine.
- 2) If any operational functions need to be fixed, it is necessary to implement after pressing the red "Emergency Shutdown" button.
- 3) Select and operate the red "Emergency Shutdown" button of the lower control box to shut down the platform.

9.5 Emergency Power

If the main power fails, the emergency power should be used.

- 1) Turn the key switch to the ground or platform for control.
- 2) Pull out the red "Emergency Shutdown" button to the "ON" position.
- 3) When operating the power unit (i.e., emergency pump) on the platform, press the foot switch.
- 4) Enable the desired function while keeping the power unit (i.e., emergency pump) open. The drive function will not work with the power unit.

- 5) Do not use the emergency power for a period of more than 30min.

9.6 Operation from the Ground Control Station

- 1) Turn the key switch to the lower control box.
- 2) Pull the red "Emergency Stop" button to the "ON" position.
- 3) Push the engine startup switch of the engine to the start position for 2s to 3s, followed by starting up the engine.
- 4) Adjust platform position.
 - Press and hold the function enabling button.
 - Move the proper toggle switch according to the mark on the control panel, and adjust the platform to a suitable position. Driving and steering functions cannot be used from the ground.

9.7 Operation from the Platform Control Station

- 1) Turn the key switch to the upper control box position.
- 2) Pull out the red "Emergency Shutdown" buttons on the ground and the platform to the "ON" position.
- 3) Push the engine startup switch to the start position for 2s to 3s, followed by starting up the engine. Do not step down on the pedal switch when starting up the engine.
- 4) Adjust platform position.
 - Step down on the pedal switch.
 - Slowly activate the function control handle or the toggle switch as per the icon on the control panel.



5) Steering

- Step down on the pedal switch.
- Turn the steering wheels by pushing the thumb rocker on the top of the control handle. Press the button on the left side of the thumb rocker, the steering wheel of the machine will turn left; and press the button on the right side of the thumb rocker, the steering wheels of the machine will turn right.

⚠ CAUTION: Determine the steering direction of the wheels using the direction arrows on the upper control box and the machine chassis.

6) Driving

- Step down on the pedal switch.
- Increase the speed: Slowly move the driving controller handle, making it off center.
- Decrease the speed: Slowly move the driving controller handle, making it point at the center.

Stop: Return the driving control handle to the center position or release the pedal switch.

⚠ CAUTION: Determine the direction of driving the machine using color label direction arrows on the upper control box and the driving chassis.

7) Drive the machine on a slope.

- Determine the uphill, downhill and side slope ratings of the vehicle.



Maximum slope rating, platform downhill: 30% (17°)



Maximum slope rating, platform uphill (climbing ability): 45% (24°)



Maximum slope rated value: 25% (14°)

⚠ CAUTION: The slope rating is limited by the ground conditions and traction.

- Make sure the boom is below horizontal position and the platform is between the non-steering wheels. Select machine on incline drive setting.
- Determine the slope using the following procedure.

Measure the slope with a digital inclinometer or follow the steps below.

- ✓ The following tools are required: Carpenter's ruler, straight block at least 3.3ft. (1 m) long, and a tape measure.
- ✓ Place the wood block on the slope, place the carpenter's ruler on the upper edge of the wood block at the end of the downhill slope and raise the end of the block until it is level.
- ✓ Keep the block level and measure the vertical distance from the bottom of the block to the ground.
- ✓ d) Divide the tape measure distance (the raised height) by the block length (travel) and multiply by 100.

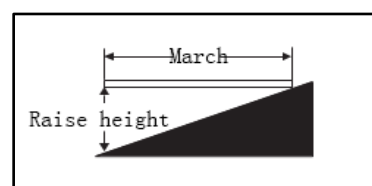



Example:

Wood block = 11.8ft

Travel = 11.8ft

Raised height = 0.98ft

$0.98/11.8=8.3\%$ rating

If the slope exceeds the maximum uphill, downhill or side slope rating, the vehicle must be lifted or transported up and down the slope. See the Transportation and Lifting section for further instructions on transporting the machine.

8) Drive enabling

- If the indicator flashes, it indicates that the boom has moved beyond one of the two non-steering wheels and the drive function is disabled.
- To drive, turn the driving enabling switch to either side, while slowly moving the driving control handle away from the center position.

Note: The vehicle may move in the opposite direction to the drive and steering control handles.

- Always determine the direction in which the vehicle drives according to the directional arrow on the upper control box.

9) Selection of drive speed

- The machine is located at sign on the slope: The engine is switched to high idle speed automatically. To acquire more driving torque, select the slope sign on the inclined or rough ground.
- The machine is located at the sign on the horizontal plane: For operation of maximum driving speed.

10) Selection of engine idle speed

- Select engine idle speed with the sign

on the control panel.

- In the case of failure to stepdown of pedal switch or toggling of handle, the engine will keep idle speed at the lowest revolution.

Turtle sign: Step down on the pedal switch to activate low idle speed.

Rabbit sign: Step down on the pedal switch to activate high idle speed.

9.8 Platform Overload

The platform overload indicating lamp is ON, and the alarm gives an alarm, indicating the slight overload of platform. Unload the platform until the lamp is OFF before continuing to operate.

9.9 Tilt Indicator

If the lamp is on, it indicates the vehicle is not level. When the indicator is on, the alarm will sound and the vehicle must be moved to a hard, level surface. Determine the state of the articulating boom on slope, as shown below. Before moving the machine to the solid and horizontal ground, lower the articulating boom per the following steps. Before lowering the boom, do not rotate the boom.

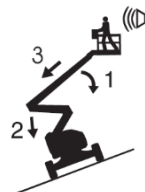

If the tilt alarm sounds on the up-slope of platform:

1. Lower the first boom.
2. Lower the second boom.
3. Retract the first boom.

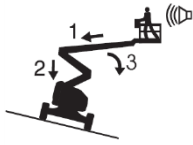

If the tilt alarm sounds on the down-slope of platform:

1. Retract the first boom.
2. Lower the second boom.
3. Lower the first boom.

9.10 System Fault

The alarm sounds, and the system fault indicating lamp is ON, indicating that the control system has a fault. The LED display will show the corresponding fault code, and the corresponding functions of the machine will be shut down, shown as Table 9-1.

When the system indicating lamp is ON, operate as per the following steps:

- 1) Lower and retract boom.
- 2) Move the machine to the stowed position, shut down the engine, tag out the machine and shut down.
- 3) The machine can be used again only after relevant qualified personnel maintain, troubleshoot and conduct complete inspection.
- 4) System fault code is shown as the following figure:



Fault Code	Fault Description	Limit Action	Fault Code	Fault Description	Limit Action
1	Cutoff of controller output power supply 1	Base boom /folding boom luff-up	12	Fault of right handle	Actions controlled by PCU joystick limited
2	Cutoff of controller output power supply 2	Base boom /folding boom luff-up	13	Fault of middle handle	Actions controlled by PCU joystick limited
3	Cutoff of controller output power supply 3 and 4	Base boom /folding boom luff-up	14	Base boom luffing limit switch fault	Low-speed walking only
4	Disconnection of CAN bus of extended module of electric box of platform	PCU action limitation	15	Folding boom luffing limit switch fault	Low-speed walking only
5	Chassis electric box display Bus break circuit		16	Base boom telescoping limit switch fault	Low-speed walking only
7	Weighing sensor 1 fault	All actions limited	17	Rear area detection limit switch fault	Low-speed walking only
8	Weighing sensor 2 fault	All actions limited	101	Chassis inclination	Base boom /folding boom lifting, extension and rotary table swing limited
9	Weighing sensor checkout fault	All actions limited	102	Walking motion is limited due to unactivated drive	Walking
11	Fault of left handle	Actions controlled by PCU joystick limited	103	Working platform overweighted	All actions limited
			104	Low Fuel level warning	

Table 9-1 System fault codes and limit actions



chocks

9.11 Parking and Storage

- 1) Select a solid, level, and safe position where it is moisture-proof, high-temperature resistant, open flame resistant, free from corrosive gas and well-ventilated.
- 2) Retract and lower the boom to the stowed state.
- 3) Close and lock all enclosures and box doors.
- 4) Wipe up dust and oil dirt on the machine body, and keep the machine clean.
- 5) Rotate the turntable to make the boom located between non-steering wheels.
- 6) Turn the key toggle switch to the "OFF" position, and remove the key to avoid unauthorized use.
- 7) When preparing the machine for outdoor storage, protect the exhaust pipe with a waterproof cover against rain and snow ingress into the muffler through it. (Caution: As the exhaust pipe can be hot just after the machine stops, use extreme caution to avoid scalding.)
- 8) During long-term storage:
 - Disconnect the positive and negative electrodes of the battery, drain the fuel completely, and prior to use, conduct overall cleaning and maintenance on the entire machine.
 - When the storage period exceeds three months, run the machine for not less than one hour every three months, and conduct cleaning and maintenance.
 - Secure the wheels using wheel

9.12 Function of Safety

Protection Devices (SPD)

When the safety rod is activated and disengages, the SPD's function will be triggered and all ongoing motions will be stopped. At that time, the blue strobes flash. If the operator presses down the foot switch and attempts to operate the machine, the horn will sound an alarm and no functions will operate. Only when the operator conducts the emergency operation or presses and holds the reset switch, the functions will operate.

The reset switch is on the right of the platform control box, or on the platform box panel depending on the machine models.



Figure-SPD Activated State



Figure-The Strobe Flashes Blue



Figure-Reset Switch 1

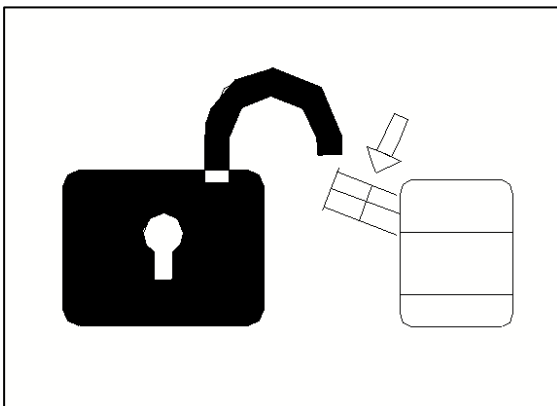



Figure-Reset Switch 2

After the machine is powered on,

disengage the safety rod from the proximity switch, and the strobes will flash. Press down the foot switch and the horn will sound immediately. With the foot switch pressed down and being held, press and hold the reset button, operate the joystick, and all functions of the machine will operate normally.

9.13 Low Temperature Start Kit (If Equipped)

 **Risk of scalding:** It is prohibited to touch the heated heaters.

 **Risk of fire:** It is prohibited to place inflammables and explosives around the heaters.

 **Risk of electric shock:** It is prohibited to wash the heaters directly with water. It is only allowed to connect the heater power line to a grounded AC three-wire outlet with a leakage protector.

The low temperature start kit is



prohibited to use, when the ambient temperature is above 0°C.

The low temperature start kit aims to start the machine normally and have it run smoothly at low temperature through heating of related devices by the externally powered heaters installed on the engine, battery and hydraulic oil tank.

Connection example:

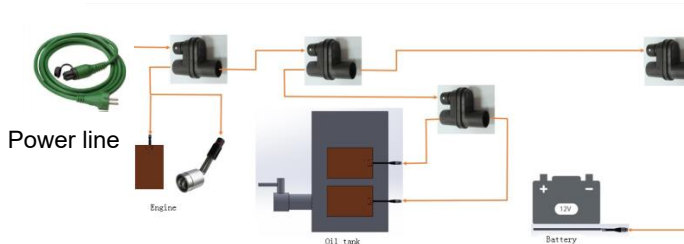

Recommended heating duration:

Model	Ambient temperature above -20°C	Ambient temperature below -20°C
AR45J/AR52J	<2h	2h< heating duration < 4h

9.14 DPF Regeneration (If Equipped)

DPF is designed to reduce environmental pollution and harm to human health by filtering particulate matter from engine exhaust gas.

Automatic DPF regeneration: DPF automatically removes particulate matter

accumulation in it.

Manual regeneration: If the machine is free of any engine and system fault and alarm, in the stowed position and motionless, and the DPF alarm indicator light of GCU is on, manual regeneration will be required.



Notice: During manual DPF regeneration, there is more exhaust gas, which is hotter. Check the surrounding areas and ensure there is no flammable material and the ventilation is good.



Notice: If a manual regeneration request is ignored, smoke in the DPF may reach the extreme level. The filter will be damaged permanently and shall be replaced by qualified technical maintenance personnel.



Notice: On an engine equipped with the DPF, partial fuel may be mixed with the engine oil during the regeneration process. Therefore, the engine oil may be diluted and the engine oil may be increased. If the engine oil exceeds the upper limit of the level gauge, the engine oil is diluted too much, leading to a fault. In this condition, please replace the



engine oil immediately.

If the DPF regeneration interval is 5 hours or shorter, please replace the engine oil.

Notice: Please check the engine and place it at a horizontal position. If it is placed on an inclined surface, the oil capacity cannot be measured.

- 1) Pull out the Emergency Stop switch and turn the key switch to ground control.

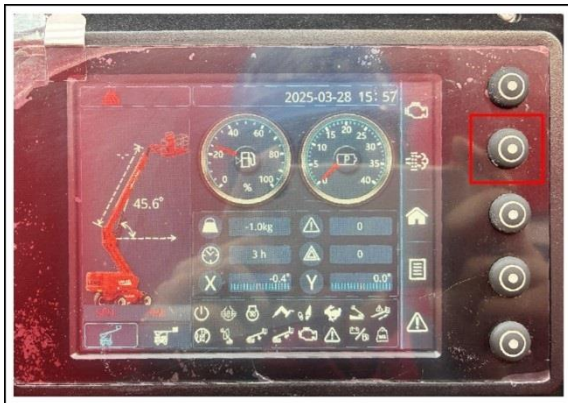

- 2) Press the button indicated in the picture to go into the regeneration system screen.



- 3) Start and idle the engine until coolant temperature exceeds 60°C.



- 4) Move the DPF regeneration toggle switch and the engine will slow down to 1100r/min. Move the DPF regeneration toggle switch again and the engine will slowly speed up to 2200r/min.
- 5) Wait for the engine to automatically complete DPF regeneration.

Automatic regeneration inhibition



Danger: Auto-regeneration shall be prohibited in some working sites.

- 1) Pull out the Emergency Stop switch and turn the key switch to ground control.

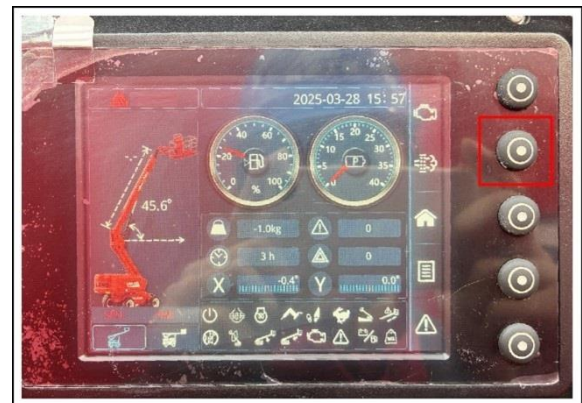

- 2) Press the button indicated in the figure



to go into the regeneration system screen.



2) All PFPE must comply with applicable governmental regulations, and must be inspected and used in accordance with the PFPE manufacturer's instructions.

- 3) Press the "Confirm" button to enter the PDF regeneration initiate/inhibit function screen.
- 4) Select the PDF regeneration initiate/inhibit function as appropriate and press the "Confirm" button.



Notice: If automatic DPF regeneration is inhibited over a prolonged period of time and manual DPF regeneration is ignored, smoke in the DPF may reach the extreme level. The filter will be damaged permanently and shall be replaced by qualified technical maintenance personnel.

9.15 Fall Protection

- 1) Personal fall protection equipped is required when operating the machine.





Chapter 10 Instructions for Transportation and Lifting





10.1 Compliance

- 1) Only personnel with high-altitude lifting qualifications can load and unload the vehicle.
- 2) The transport vehicle must be parked on a level surface.
- 3) When loading the vehicle, the transport vehicle must be secured to prevent movement.
- 4) Make sure the transport vehicle's capacity, loading surface, chains or belts are sufficient to withstand the weight of the vehicle. Refer to the nameplate for the weight of the vehicle.
- 5) Make sure the turntable has been secured with the rotation lock before transporting. Make sure to unlock the turntable before operation.
- 6) Do not drive the vehicle on a slope that exceeds the vehicle's uphill, downhill or slope rating. Refer to "Drive on the Slope" in the "Operation Instructions" section.
- 7) If the slope of the transport vehicle exceeds the maximum slope rating, the winch must be used to load and unload the vehicle as specified.
- 8) The vehicle is equipped with a sophisticated weighting system. It is forbidden to place heavy goods on the platform, when the vehicle is transporting, otherwise the weighting system may be damaged.

10.2 Freewheel Configuration for Trailers

- 1) Wedge the wheel to prevent the vehicle from moving.
- 2) Flip over the drive hub cover to release

the non-steering wheel brake.

- 3) Make sure that the winch cable is properly secured to the fastening point of the drive chassis and that there are no obstacles in the moving direction.

After the vehicle is loaded:

- ① Wedge the wheel to prevent the vehicle from moving.
- ② Flip over the drive hub cover to engage the non-steering wheel brake.



CAUTION: Do not tow the vehicle. If the vehicle must be towed, the speed may not exceed 3.2km/h.

10.3 Transportation Safety

- 1) The vehicle wheels must always be locked when preparing for transport.
- 2) Before transporting, turn the key switch to the "OFF" position and remove the key.
- 3) Thoroughly inspect the vehicle to prevent loose or unsecured parts.
- 4) Secure the vehicle to the transport surface with the fastening points on the chassis.
- 5) Use at least four chains or belts.
- 6) Make sure the chain or belt used has sufficient load strength.
- 7) Adjust the sling to prevent damage to the chain.

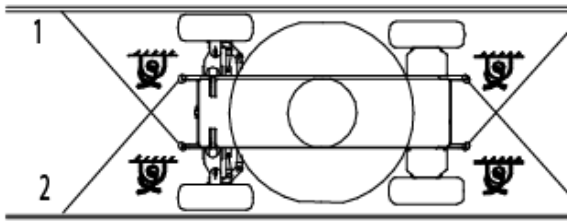

- 8) Make sure that the Jib and platform are telescoped. Protect the platform with the nylon strap on the platform base near the platform rotator (as shown below). Do not apply excessive downward force when protecting the boom components.

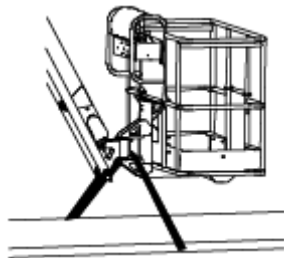

chassis.

- 4) Adjust the sling to avoid any damage to the vehicle and keep the vehicle in a level position.

Model	X	Y
AR45J	970mm/38.2in	1070mm/42.1in
AR52J	1150mm/45.3in	1170mm/46.1in

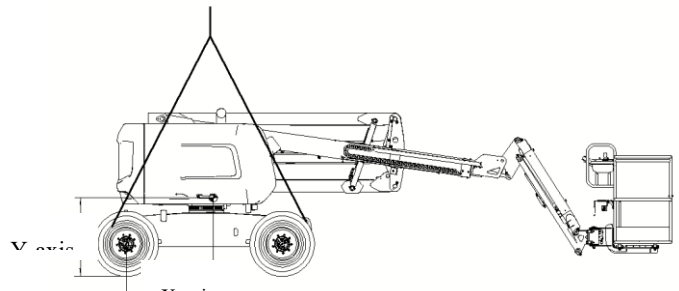

10.4 Lifting Instructions

Keep in mind the following:

- 1) Only qualified rigging personnel can assemble the sling and lift the vehicle.
- 2) Make sure that the crane's lifting capacity, loading surface, belt or rope is sufficient to withstand the weight of the vehicle. Refer to the label and nameplate for the weight of the vehicle.

Lifting instructions

- 1) Lower and retract the boom completely. Lower the Jib completely. Remove any loose parts from the vehicle.
- 2) Determine the center of gravity of the vehicle with the help of the picture below.
- 3) Only connect the lifting sling to the specified lifting point on the vehicle. There are four lifting points on the

