



OPERATOR MANUAL

Includes Safety, Service and Replacement Part Information

**Model SG24
Series Surface Grinder**

**Form: GOM3259601
Version 1.2**

Do not discard this manual. Before operation, read and comprehend its contents. Keep it readily available for reference during operation or when performing any service related function. When ordering replacement parts, please supply the following information: model number, serial number and part number. For customer service assistance, telephone 800.533.0524, +507.451.5510. Our Customer Service Department telefax number is 877.344.4375 (DIGGER 5), +507.451.5511. There is no charge for customer service activities .

Internet address: <http://www.generalequip.com>.
E-Mail location: general@generalequip.com.

Copyright 2003, General Equipment Company.



620 Alexander Dr. S.W. • PO Box 334
Owatonna, Minnesota 55060
800.533.0524 • +507.451.5510
Fax +507.451.5511
Toll-Free Fax 877.344.4375 (Digger 5)
Web: www.generalequip.com
E-mail: general@generalequip.com
Can you really afford anything less?



Congratulations on your decision to purchase a General light construction product. From our humble beginnings in 1955, it has been a continuing objective of General Equipment Company to manufacture equipment that delivers uncompromising value, service life and investment return. Because of this continuous commitment for excellence, many products bearing the General name actually set the standards by which competitive products are judged.

When you purchased this product, you also gained access to a team of dedicated and knowledgeable support personnel that stand willing and ready to provide field support assistance. Our team of sales representatives and in house factory personnel are available to ensure that each General product delivers the intended performance, value and investment return. Our personnel can readily answer your concerns or questions regarding proper applications, service requirements and warranty related problems.

General Equipment Company places great emphasis upon not only product performance, but also on product safety. It is important to remember that this product will only be as safe as the operators which utilize it. It just makes good, common sense to take the time to read and fully understand the contents of this manual before attempting to utilize this product in service. If you ever do have any questions or concerns about this product, please feel free to contact our Customer Service Department at the telephone numbers listed below for assistance.

If there is anything that I can do to assist your efforts when utilizing this product, please do not hesitate to contact me. For assistance after normal business hours, telephone me at 507.451.9409 or 507.363.1033. If I am not immediately available, I will attempt to return your call as soon as possible.

Sincerely,

GENERAL EQUIPMENT COMPANY

Dennis Von Ruden
President

Table of Contents

DESCRIPTION	PAGE
<i>Notice to Operators</i>	4
<i>Operational Instructional Data Sheet</i>	5
<i>Safety Precautions</i>	7
Preparation.	7
Operation.	9
Maintenance, Repair and Storage.	10
<i>Assembly</i>	11
Removing the Surface Grinder From the Pallet.	11
Installing the SG24-1000 Safety and Dust Shield Assembly Kit.	12
<i>Before Starting the Engine</i>	14
Filling the Engine Crankcase with Oil.	14
Filling the SG24/G Series Engine Fuel Tank.	14
Filling the SG24/GHP Propane Cylinder.	14
<i>Operation</i>	15
Theory of Operation	15
Multi-Accessory Attachments and Applications.	15
Installing a Multi-Accessory Attachment (not including multi-segmented, dry diamond discs) in the Counterrotating Discs.	24
Removing a Multi-Accessory Attachment (not including multi-segmented, dry diamond discs) from the counterrotating discs.	26
Transporting the Surface Grinder.	27
Adjusting the Operator Handle Height.	27
Starting the SG24/E Series Electrically Powered Surface Grinder on the Job Site .	28
Starting the SG24/G Series Gasoline Powered Surface Grinder on the Job Site.	30
Procedures for the Safe handling of Propane.	31
Example of a Propane Emergency Plan.	31
Starting the SG24/GHP Propane Converted Surface Grinder on the Job Site.	32
Counteracting the Propane Refrigeration Effect.	33
Operating the Surface Grinder on the Job Site.	34
Stopping the SG24/E Series Electrically Powered Surface Grinder.	38
Stopping the SG24/G Series Gasoline Powered Surface Grinder.	38

Continues on next page

DESCRIPTION	PAGE
Stopping the SG24/GHP Propane Converted Surface Grinder	38
Operational Parameters and Techniques for the SG24 Series Surface Grinder.	38
<i>Service</i>	41
Preventative Maintenance Check List.	41
Checking V-Belt Tension and Alignment.	42
Installing a Replacement V-Belt, Centrifugal Clutch or Pully.	43
Replacing the Lord® Type Elastomeric Mounts on the Multi-Accessory Discs.	45
Lubrication Requirements.	47
Electric Motor Service.	48
Engine Service.	48
<i>Troubleshooting</i>	48
Electric Motor.	48
Engine.	49
Operational Problems.	49
<i>Storage</i>	50
<i>Specifications</i>	50
<i>Replacement Parts Diagrams</i>	53

Notice to Operators

IF YOU CAN NOT READ OR DO NOT FULLY UNDERSTAND THE CONTENTS OF THIS MANUAL, PLEASE CONTACT THE FACTORY FOR PROPER ASSISTANCE BEFORE ATTEMPTING TO OPERATE THIS PRODUCT.

SI TU NO PUEDES LE'ER O NO COMPRENDES EL CONTENIDO DE ESTE MANUAL FAVOR DE PONERSE EN CONTACTO CON LA FABRICA PARA ASISTENCIA- A PROPIA ANTES DE INTENTAR PARA OPERAR ESTE PRODUCTO.

SOLLTEN SIE DIESE GEBRAUCHSANWEISUNG NICHT LESEN KOENNEN ODER ES NICHT VOLLKOMMEN VERSTEHEN, WENDEN SIE SICH BITTE AN DEN HERSTELLER FUER RICHTIGE HILFE EHE SIE VERSUCHEN DIESES PRODUKT ZU OPERIEREN.

SI VOUS NE LISEZ OU NE COMPRENDRE ENTIEREMENT LES MATIERES DE CE MANUEL, S'IL VOUS PLAIT, CONTACTEZ L'USINE POUR L'ASSISTANCE APPROPRIEE AVANT D'UTILISER LE PRODUIT.



DANGER



CAUTION

These safety alert symbols identify important safety messages in this manual. When you see these symbols, be alert to the possibility of personal injury and carefully read the message that follows.

Do not allow anyone to operate the Surface Grinder without first reading this Operator's Manual and becoming familiar with its operation. The manufacturer of this Surface Grinder has gone to great extremes to provide the owner(s) and/or operator(s) with the finest equipment available for its intended job function of providing a variety of industry recognized surface preparation functions on horizontal floor surfaces. Yet, the possibility exists that the Surface Grinder can be utilized in and/or subjected to job applications not perceived and/or anticipated by the manufacturer. Such misuse and/or misapplication of the Surface Grinder can lead to the possibility of serious damage, injury or even death. It is the responsibility of the owner(s) and/or operator(s) to determine that the Surface Grinder is being utilized and/or operated within the scope of its intended job function. It is the responsibility of the owner(s) and/or operator(s) to establish, monitor and constantly upgrade all safety programs and/or practices utilized in and for the operation of the Surface Grinder. The purpose of such programs is to provide for owner(s)' and/or operator(s)' safety. Operators must be instructed to recognize and avoid unsafe conditions associated with their work (29 CFR 1926.21 (b)(2)) and/or applicable updated revisions. It is the responsibility of the owner(s) and/or operator(s) to determine that no modifications and/or alterations have been made to the Surface Grinder. Modifications and/or alterations can lead to the possibility of serious damage, injury or even death. It is the responsibility of the owner(s) and/or operator(s) to make this Operator's Manual available for consultation during all phases of operation. Refer to OSHA 2207 and/or applicable updated revisions which contains all OSHA job safety and health rules and regulations (1926 and 1910) covering construction.



CAUTION

The concept of powered Surface Grinder has been successfully utilized for many years as a practical solution to many types of surface preparation requirements. The basic concept is proven and well accepted within the associated marketplace. Use of a Surface Grinder requires strenuous work activity. This type of work activity can be considered to be greater in magnitude than that experienced with the use of many other types of both light construction and lawn and garden related equipment. This type of work activity should only be attempted by operators of adequate physical size and stature, mental awareness and physical

strength and condition. The body parts most noticeably affected during any specific process are the arms, hands, wrists, shoulders, lower back and legs. The process can also produce excessive stress/strain directly to the back muscles, spinal vertebrae and many other body parts. Back related pain can be a side effect of utilizing a Surface Grinder. An operator with a chronic back related problem or a history of back and/or other medically related problems should not attempt to utilize the Surface Grinder. Use of the Surface Grinder may only aggravate this and any other medically related problem. Because of the diverse type of prevailing job applications, job site conditions, operator experience levels and operator physical characteristics, no warranty, guarantee, representation and/or liability is made by the manufacturer as to the absolute correctness or sufficiency of any operational procedure, operational position and/or technique. There is no absolute guarantee that an operator of any given experience level, physical size and/or physical condition will be immune to the possibility of and/or probable physical side effects of the normal use of the Surface Grinder. Each potential operator must be made aware of and assume the operational and physical liability described and/or associated with the use of the Surface Grinder. Improper use of the Surface Grinder can result in property damage and/or personal injury, including death. Each potential operator not willing to assume the operational and physical liability described and/or associated with the use of the Surface Grinder, should not operate it. Proper levels of operator experience, skill and common sense are essential for maximizing the safe and efficient operation of the Surface Grinder.

Record the Surface Grinder and engine/electric motor serial numbers in the spaces provided below.

_____ **Model Number**

_____ **Serial Number**

_____ **Engine/Electric Motor Serial Number**

_____ **Date of Purchase**

Specifications and design are subject to change without notice or obligation. All specifications are general in nature and are not intended for specific application purposes. General Equipment Company reserves the right to make changes in design, engineering or specifications and to add improvements or discontinue manufacture at any time without notice or obligation. General Equipment Company and its agents accept no responsibility for variations which may be evident in actual products, specifications, pictures and descriptions contained in this publication.

Operator Instructional Data Sheet

The following undersigned operators of the Surface Grinder described and/or pertaining to this Operator's Manual have received formal safety and operational information/instruction from the undersigned owner(s)/instructor(s) in accordance to OSHA 29 CFR 1926.21 (b)(2) and/or applicable updated revisions pertaining to, but not necessarily limited to the:

1) READING, COMPREHENSION AND ACKNOWLEDGEMENT OF THE MATERIAL COMPRISING THE ENTIRE CONTENTS OF THE APPLICABLE OPERATOR'S MANUAL AND SAFETY AND OPERATIONAL INFORMATION VIDEO TAPE FOR THE SURFACE GRINDER.

2) FORMALIZED OPERATOR'S SAFETY PROGRAM TO BE DEvised BY THE OWNER OF THE

SURFACE GRINDER IN CONJUNCTION WITH THE CONTENTS OF THE APPLICABLE OPERATOR'S MANUAL, SAFETY AND OPERATIONAL INFORMATION VIDEO TAPE FOR THE SURFACE GRINDER AND THE APPLICABLE MATERIAL INCLUDED IN THE NATIONAL ELECTRIC CODE®.

3) OSHA AND NATIONAL ELECTRIC CODE® RULES AND REGULATIONS RESEARCHED FOR AND/OR BY THE OWNER OF THE SURFACE GRINDER AND DEEMED APPLICABLE TO THE SAFE AND PROPER USE AND/OR OPERATION OF THE SURFACE GRINDER FOR ANY SPECIFIC JOB APPLICATION.

4) LOCAL LAWS, REGULATIONS AND CUSTOMS RESEARCHED FOR AND/OR BY THE OWNER OF THE SURFACE GRINDER AND DEEMED APPLICABLE TO THE SAFE AND PROPER USE AND/OR OPERATION OF THE SURFACE GRINDER FOR ANY SPECIFIC JOB APPLICATION.

5) FORMALIZED MAINTENANCE PROGRAM FOR THE SURFACE GRINDER TO BE DEVISED BY THE OWNER OF THE SURFACE GRINDER IN ACCORDANCE WITH, BUT NOT NECESSARILY LIMITED TO, THE SPECIFICATIONS, GUIDELINES AND OPERATIONAL INFORMATION CONTAINED IN THE APPLICABLE OPERATOR'S MANUAL.

6) COMPREHENSIVE OPERATIONAL INSTRUCTIONS FOR THE CORRECT AND PROPER USE OF THE SURFACE GRINDER AS PER THE CONTENTS OF THE APPLICABLE OPERATOR'S MANUAL, SAFETY AND OPERATIONAL INFORMATION VIDEO TAPE AND APPLICABLE MATERIAL INCLUDED IN THE NATIONAL ELECTRIC CODE®.

_____ Operator	_____ Owner/Instructor	_____ Date
_____ Operator	_____ Owner/Instructor	_____ Date
_____ Operator	_____ Owner/Instructor	_____ Date
_____ Operator	_____ Owner/Instructor	_____ Date
_____ Operator	_____ Owner/Instructor	_____ Date
_____ Operator	_____ Owner/Instructor	_____ Date

NOTE: INSERT COPIES OF THIS PAGE WITHIN THE OPERATOR'S MANUAL IF SPACE FOR ADDITIONAL OPERATORS IS REQUIRED.

Safety Precautions



DANGER

THE FOLLOWING SAFETY PRECAUTIONS PROVIDE SOME COMMON SENSE GUIDES TO PROMOTE SAFETY AND EFFICIENCY WITH THE SURFACE GRINDER. NO WARRANTY, GUARANTEE OR REPRESENTATION IS MADE BY THE MANUFACTURER AS TO THE ABSOLUTE CORRECTNESS OR SUFFICIENCY OF ANY INFORMATION OR STATEMENT. THESE SAFETY PRECAUTIONS ARE INTENDED TO DEAL PRINCIPALLY WITH COMMON PRACTICES AND CONDITIONS ENCOUNTERED IN THE USE OF THE SURFACE GRINDER AND ARE NOT INTENDED TO BE ALL INCLUSIVE. PROPER LEVELS OF OPERATOR EXPERIENCE, SKILL AND COMMON SENSE ARE ESSENTIAL FOR SAFE AND EFFICIENT OPERATION.



DANGER

THE ENGINE EXHAUST FROM THIS PRODUCT CONTAINS CHEMICALS KNOWN TO THE STATE OF CALIFORNIA TO CAUSE CANCER, BIRTH DEFECTS OR OTHER REPRODUCTIVE HARM. THIS STATEMENT IS MADE IN COMPLIANCE TO CALIFORNIA PROPOSITION 65.



DANGER

INCORRECT USE OF THE SURFACE GRINDER CAN RESULT IN PROPERTY DAMAGE, PERSONAL INJURY OR EVEN DEATH. TO REDUCE THIS POSSIBILITY, GIVE COMPLETE AND UNDIVIDED ATTENTION TO THE JOB AT HAND AND FOLLOW THESE SAFETY PRECAUTIONS:

PREPARATION.

1) This Surface Grinder is a specialized type of powered equipment, designed for a specific job function and requires adequate and thorough instruction BEFORE it is operated. The size, power, complexity and operating characteristics of this type of powered equipment would dictate that each operator

must receive adequate, professional instruction regarding the proper operation of this Surface Grinder before being allowed to utilize it. BEFORE attempting to utilize this Surface Grinder, read this Operator's Manual, the applicable Safety and Operating Information Video Tape and the material supplied by the engine manufacturer to familiarize each operator with its correct operating procedures. Avoid the urge not to take the necessary time to read this Operator's Manual before operating the Surface Grinder. DO NOT OPERATE THE SURFACE GRINDER UNTIL EACH OPERATOR COMPLETELY COMPREHENDS THE CONTENTS OF THIS MANUAL AND THE APPLICABLE SAFETY AND OPERATIONAL INFORMATION VIDEO TAPE.

2) Develop a comprehensive program for the safe operation of the Surface Grinder by its owner(s) and/or operator(s). Such a program will include, but is not limited to: instructional requirements for operation, applicable OSHA requirements, local laws and regulations, job site safety and a Surface Grinder maintenance program. Constantly examine and upgrade this program to guarantee owner(s) and/or operator(s) safety. Each operator must be fully instructed regarding the specifics of this safety program.

3) Determine that the Surface Grinder is in its original, factory configuration and has not been modified in any manner. Many modifications can result in potentially dangerous configurations that can lead to property damage and/or personal injury. If there are any questions about possible modifications made to the Surface Grinder, contact the Customer Service Department for specific information BEFORE utilization. There is no charge for this service. Do not operate the Surface Grinder without the use of the original equipment V-belt guard. Use of the Surface Grinder without an approved belt guard can lead to property damage and/or personal injury.

4) Minors should never be allowed to operate the Surface Grinder. Bystanders, especially children and animals, should not be allowed in the area where the Surface Grinder is in use. The grinding process can result in flying particles being emitted at high velocity and striking the operator and/or onlookers. This can lead to the possibility of property damage and/or personal injury. Keep all body parts, loose clothing, foreign objects and onlookers clear of the rotating discs, multi-accessory attachments and flying particles.

5) Operators must be in adequate physical condition, mental health and not under the influence of any substance (drugs, alcohol, etc.) which might impair vision, dexterity or judgment. Working with the Surface Grinder is strenuous. If you have any condition that might be aggravated by strenuous work, check with your doctor BEFORE operating the Surface Grinder. Guard against the possibility of back related injuries. Always lift the Surface Grinder with leg muscles and not with the back.

6) Prolonged use of the Surface Grinder (or other, similar machines) exposes the operator to vibrations which may produce Whitefinger Disease (Raynaud's Phenomenon). This phenomenon reduces the hand's ability to feel and regulate temperature, produces numbness and burning sensations and may cause nerve and circulation damage and tissue necrosis. Antivibration systems do not guarantee that you will not sustain Whitefinger Disease. Therefore, continuous and regular users should closely monitor the condition of their hands and fingers. After each period of use, exercise to restore normal blood circulation. If any of the symptoms appear, seek medical advice immediately.

7) Clothing must be sturdy and snug fitting, but allow complete freedom of movement. Never wear loose fitting jackets, scarves, neckties, jewelry, flared or cuffed pants or anything that could become caught on controls or moving parts. Wear long pants to protect your legs. Protect your hands with heavy duty, nonslip gloves to improve your grip. Good footing is most important when operating the Surface Grinder. Wear sturdy boots with nonslip soles. Steel-toed safety shoes are highly recommended. Never wear tennis shoes or other, similar type shoes which afford little or no protection. Wear an approved safety hard hat to protect the operator's head(s) where there is a danger of head injuries. Noise, generated by the engine of the Surface Grinder and the actual process itself, can damage your hearing. Wear approved sound barriers (ear plugs or ear muffers) to protect your hearing. Continuous and regular operators should have their hearing checked regularly.

8) Visually inspect the Surface Grinder, components, tools and accessories for damaged or worn parts. BEFORE each use:

a) Disconnect the engine spark plug wire or power source cable.

b) Clean and remove all accumulated foreign matter

from the wheels and determine that each rotates freely.
c) Clean and remove all accumulated foreign matter from inside the main frame area.

d) Inspect the V-belt drive for proper tension, wear and general condition. Replace each component as necessary.

e) Inspect the multi-accessory discs and gimbal head assemblies for excessive wear and structural integrity. Replace each component as necessary. The multi-accessory discs rotating at high speed during the specific process can be subject to high wear rates if the installed attachment is not properly maintained and/or replaced at regular service intervals.

f) Determine that operator controls work freely, all safety devices are operative and information decals are readable.

g) Check to see that the Surface Grinder and all related accessories are in good, mechanical condition BEFORE utilization.

h) Reconnect the spark plug wire or power source cable as applicable.

9) Contact appropriate representatives to determine if/where electrical cables, gas lines and other hazardous items are buried under the work surface BEFORE utilization. The Surface Grinder and related accessories are not insulated. Contact with buried electrical cables, gas lines and other hazardous items can result in electrocution and/or an explosion.

10) Know how the controls operate. Know how to stop the engine or electrical motor quickly in an emergency. Always start the engine or electric motor according to the instructions as outlined in this manual to minimize the possibility of unexpected contact with the work surface. Unexpected contact with the work surface can cause loss of machine control, and the possibility of property damage and/or personal injury.

11) Ground the SG24/E electrically powered Surface Grinder motor securely. Determine that any "grounding" wire and/or device is, in fact, properly grounding the motor. Failure to properly ground the motor may cause an electrical shock and/or electrocution, resulting in property damage and personal injury including death. Electrical wiring and all connections should be performed by a qualified electrician. Depending upon the wiring configuration, the electric motor is designed to operate from either 115 or 230 volt, AC power sources. Determine that the

electric motor voltage switch is properly selected according to the intended and/or available power source. Operating the electric motor from an improper voltage/amperage power source can result in property damage and/or personal injury.

12) When operating the SG24/E electrically powered Surface Grinder on a surface containing water or other electrically conducting liquid, special precautions must be taken to minimize the possibility of operator electrocution. One such precaution is to wire and operate the electric motor from a clean, 20 Ampere, 115 Volt AC power source in conjunction with a ground fault circuit interrupter (GFCI). A GFCI is a safety device that disconnects power from a circuit to a load when a potentially dangerous condition occurs. The GFCI opens the circuit when the fault current flow from a power line to a ground exceeds the safe limit for humans. The GFCI protects against harmful electrical shock to a person caused by contact with a defective electrical product. A GFCI differs from a fuse or circuit breaker. A fuse or circuit breaker opens the circuit when the total current flow in the power line exceeds the safe limit of the power line. They are designed to protect against fire caused by overheating of the power line. Use of a GFCI gives on the job protection from electrical shock hazards caused by ground faults in commercial, industrial and residential applications. They are simple and easy to use: plug a portable GFCI into any suitable, grounded extension cord and plug the Surface Grinder into the GFCI for automatic protection against ground faults. For specific information, consult current National Electrical Code® publications and OSHA publications 210-22D (or current revision) for construction sites and 555-3 (or current revision) for use around any area containing water.

13) Never exceed the recommended capacities of the Surface Grinder. Refer to the **Specifications** section of this manual for more detailed information.

OPERATION.

1) Give complete and undivided attention to the job at hand. Do not chew gum, smoke and/or use smokeless tobacco while utilizing the Surface Grinder. Do not attempt to eat and/or drink while utilizing the Surface Grinder. Determine that eyeglasses and/or hearing aid devices are properly secured.

Use of the Surface Grinder is strenuous and causes fatigue. Help prevent the cause of an accident. Plan to take work breaks as required to help maintain proper

mental and physical alertness.

2) This Surface Grinder is not sealed or insulated. Do not operate this machine in an explosive atmosphere or near combustible materials. Refer to current OSHA and National Electric Code® rules and regulations.

3) Gasoline is an extremely flammable fuel. Use extreme caution when handling gasoline or mixing fuel. Always utilize UL® and/or CSA® approved containers for the storage and transportation of fuel. Do not smoke or bring fire or flame near the fuel. Always shut off the engine and allow it to cool before refueling. Never remove the fuel tank filler cap while the engine is running. Never operate an engine without a fuel tank filler cap. Select bare ground for fueling and move at least 10 feet from the fueling spot before starting the engine. Wipe off any spilled fuel before starting the engine and check for leakage. If a fuel or oil leak is found, do not start or run the engine until the leak is fixed and the spillage has been wiped away. Take care not to get fuel or oil on your clothing. If this happens, change your clothing immediately. Before operating the Surface Grinder, refer to the **Specifications** section of this manual for more detailed information regarding fuel and lubrication requirements.

4) The Surface Grinder is designed for use by one operator. Use of the Surface Grinder by more than one operator can lead to confusion and loss of control, resulting in property damage and/or personal injury. If it is felt that more than one person is required to operate the Surface Grinder, STOP and contact the Customer Service Department for specific operational and service/maintenance information. There is no charge for this service.

5) Do not operate the Surface Grinder with onlookers close by. Caution all onlookers to stand clear. The grinding process can result in flying particles being emitted at high velocity and striking the operator and/or onlookers. This can lead to the possibility of property damage and/or personal injury. Keep all body parts, loose clothing and foreign objects clear of the rotating drum and flails.

6) Start the engine or electric motor according to the instructions as outlined in this manual to minimize the possibility of unexpected contact with the work surface. Unexpected contact with the work surface can cause the loss of machine control and the possibility of property damage and/or personal injury.

7) Start and operate the Surface Grinder only in a well ventilated area. Carbon Monoxide fumes given off by

an engine are poisonous. Breathing these fumes can result in property damage and/or personal injury. Operate the Surface Grinder only when/where visibility and light are adequate for the job at hand. Work carefully. Always hold the operator handle firmly with both hands. Wrap your fingers around the handle, keeping it cradled between your thumbs and fingers. Always make sure the operator handle is in good condition and free of moisture, pitch, oil or grease. Wear gloves to improve your grip. Never leave the Surface Grinder running unattended.

8) Special care must be exercised on slippery conditions and on difficult, uneven surfaces. Watch for cracks, high spots and other, surface irregularities. Keep proper footing and balance at all times. The normal use of this machine is on level surfaces. Other terrains can be dangerous and should be avoided. Only properly trained operators should attempt these techniques.

9) Never start the engine or electric motor with the Surface Grinder directly over cracked, uneven or irregular surfaces. Start the engine or electric motor according to the instructions as outlined in this manual.

10) Contact with a hot, engine muffler can cause property damage and/or personal injury. Remain clear of a hot, engine muffler. Do not over speed the engine by altering the governor setting or by disconnecting the engine governor. Serious damage to the engine and/or personal injury can result.

11) Clean and remove all accumulated foreign matter from inside the main frame area after each use. This practice will maximize bearing and V-belt service life.

12) Because this Surface Grinder is classified as a low cost, hand held, low horsepower, portable type machine, it is limited in the number of practical and/or suitable job applications. A particular job site, actual surface conditions, job specifications and operator skill/common sense may dictate that a different type of machine (with characteristics of higher purchase cost, being mounted to a carrier vehicle, with greater horsepower and less mobility), method and/or process be utilized to properly complete the job with the degree of efficiency and safety required. Contact the Customer Service Department for specific information regarding suitable job applications, job sites surface conditions and operator experience/skill/common sense recommendations for this Surface Grinder BEFORE utilization. There is no charge for this service.

MAINTENANCE, REPAIR AND STORAGE.

1) Use only genuine, approved replacement parts and accessories for maintenance and repair. Use of parts and accessories manufactured by others can result in property damage and/or personal injury.

2) Follow the **Service** instructions as outlined in the appropriate section of this manual.

3) Always stop the engine and disconnect the spark plug wire or power source cable BEFORE checking or working on the Surface Grinder.

4) Always properly maintain the Surface Grinder. Frequently check all fasteners and individual parts. Built in safety features are effective only if they are maintained in good working condition. Replace any questionable part or assembly with a genuine, factory approved, replacement part. Do not forsake proper maintenance for the price of a few replacement parts. Proper maintenance does not cost... it actually pays dividends. Do not attempt any maintenance repair work not described in this manual. Have such work performed at your dealer's service facility.

5) A worn or damaged engine muffler is a fire hazard and may cause loss of hearing. Check to see that the muffler is in good condition. If the muffler is equipped with a spark arresting device, determine that it is in proper working condition at regular service intervals. Replace the spark arresting device with an approved replacement if there is any question of its integrity. It is the responsibility of the owner(s) and/or operator(s) to provide for and properly maintain a USDA approved, spark arresting muffler in an operating area specified by law. Check with appropriate governing agencies for more specific information. The Surface Grinder must not be operated if the muffler is faulty or has been removed. Contact with a hot engine muffler can cause property damage and/or personal injury.

6) Do not operate the Surface Grinder without the use of a factory approved V-belt guard that is maintained in proper structural condition. Frequently inspect the belt guard for signs of wear, cracks and other signs of fatigue. If there is any question regarding the structural integrity and/or condition of the belt guard, properly dispose and replace with a genuine, factory approved, replacement part only.

7) Maintain all safety and operation decals in proper condition. If any decal becomes damaged and/or unreadable, replace with a genuine, factory approved,

replacement part only.

8) The Surface Grinder utilizes many self locking hexagon head nuts to minimize the effects of vibration. Replace all self locking hardware with genuine, factory approved, replacement parts only.

9) Consult the information supplied by the engine or electric motor manufacturer for specific information relative to proper operational, lubrication and storage requirements.

10) Properly maintain the Propane conversion components for the SG24/GHP Surface Planer. Keep foreign objects from inflicting direct contact blows with the conversion components located next to the engine. Have only American Gas Association (AGA) and/or Canadian Gas Association (CGA) certified technician perform any necessary service work on the Propane conversion components. Properly utilize, service and store Propane cylinders according to established American Gas Association (AGA) and/or Canadian Gas Association (CGA) recommended practices. Failure to properly utilize, service and store Propane cylinders can result in property damage and/or personal injury.

Assembly

The SG24 Series Surface Grinder is shipped from the factory secured on a specially designed wooden pallet and protected from external damage by a corrugated carton or wood crate. If shipped with a corrugated carton, the Surface Grinder can be secured to the pallet by wood laths nailed to the pallet body. Remove the carton or crate immediately upon receipt using suitable tools to remove the nails.

REMOVING THE SURFACE GRINDER FROM THE PALLET.

Application: All Models

Tools Required:

- 1 each, pliers
- 1 each, claw hammer or a hammer and an appropriate pry bar

The Surface Grinder is secured to the pallet with steel banding. Using the pliers, cut and remove the banding. The Surface Grinder can then be removed from the pallet.



WEAR SAFETY GLASSES AND OTHER APPROPRIATE SAFETY APPAREL WHEN CUTTING THE STEEL BANDING AND/OR REMOVING THE CORRUGATED/WOOD SHIPPING CRATE.

Visually inspect the shipment for freight damage and/or missing parts. If shipping damage is evident, contact the delivering carrier immediately to arrange for an inspection of the damage by their claims representative. Federal law requires that a claim be filed within a specific time period. If missing parts are detected, notify your dealer who will assist you in obtaining them.

The Surface Grinder is shipped from the factory completely assembled. If ordered with the Surface Grinder, multi-accessory attachments are normally shipped separately to minimize the potential for loss during shipment.

Check all fasteners for proper security. Consult a fastener torque chart for the proper torque value if any fastener is found to require retorquing.

After April 1, 1996, all Surface Grinders are shipped from the factory with the SG24-1000 Safety and Dust Shield Assembly Kit included as a standard accessory. The kit is included in a separate package and is not normally installed by factory personnel. The owner and/or operator (has) have the option to install the skirt assembly for any specific job application. The SG24-1000 Safety and Dust Shield is designed to perform the following job functions:

1) To contain loose materials within the platform area of the Surface Grinder as a direct result of a specific process. This includes materials removed from the surface as well as any slurry mixture utilized to help maximize material removal efficiencies.

2) To provide a method for a vacuum system to help remove airborne dust related materials from within the skirt assembly. Dust related materials are usually created as a result of any specific process. A specific job application may require the reduction and/or minimization of airborne dust related materials from the atmosphere while the Surface Grinder is being operated. The kit includes a hose and necessary hardware to connect the skirt assembly to the 3 inch

diameter vacuum attachment fitting located at the rear of the machine. Use of the kit along with a suitable vacuum system will not completely remove all airborne and loose materials directly from the work surface.



DANGER

THE SG24-1000 SAFETY AND DUST SHIELD ASSEMBLY KIT IS RECOMMENDED FOR USE WHERE AND/OR WHEN PERMITTED ON SPECIFIC JOB APPLICATIONS TO MAXIMIZE OVERALL SAFETY AND PRODUCTIVITY. FINAL DISCRETION IS THE RESPONSIBILITY OF THE OWNER(S) AND/OR OPERATOR(S).



DANGER

THE USE OF THE SG24-1000 SAFETY AND DUST SHIELD ASSEMBLY KIT ALONG WITH A SUITABLE VACUUM SYSTEM TO REMOVE HAZARDOUS CLASSIFIED, AIRBORNE MATERIALS FROM THE WORK SURFACE WILL NOT ELIMINATE THE REQUIREMENT FOR PROPER SAFETY RELATED EQUIPMENT, OPERATING PLAN AND/OR PROCEDURES.

USE OF THE SG24-1000 SAFETY AND DUST SHIELD ASSEMBLY KIT ALONG WITH A SUITABLE VACUUM SYSTEM WILL NOT COMPLETELY REMOVE ALL LOOSE MATERIALS FROM THE WORK SURFACE. HAZARDOUS CLASSIFIED, LOOSE MATERIALS MUST BE REMOVED FROM THE WORK SURFACE BY PROCESSES AND/OR PROCEDURES MEETING THE APPLICABLE OSHA AND/OR EPA REQUIREMENTS.

INSTALLING THE SG24-1000 SAFETY AND DUST SHIELD ASSEMBLY KIT

Application: All Models

Tools Required:

- 1 each, 5/32 inch Allen wrench
- 1 each, 7/16 inch wrench
- 2 each, 1/2 inch wrenches
- 1 each, flat blade screwdriver

1) If the Surface Grinder is powered by an engine, disconnect the spark plug wire. If powered by an

electric motor, properly disconnect the extension cord or Surface Grinder from the power source.

2) Using the Allen wrench, remove the PN SG24-0220 bumper guard from the machine.

3) Tilt the Surface Grinder back until the operator handle comes in contact with the surface. The Surface Grinder may not be in a stable position in this configuration. To minimize the possibility of property damage and/or personnel injury, properly secure an appropriate weight to the handle for added stability. Other means can be utilized to support the frame and provide proper machine stability. Appropriate wheel chocks are also recommended, FIGURE 1.



DANGER

EXERCISE EXTREME CAUTION WHEN WORKING NEAR OR UNDER THE SURFACE GRINDER WITH THE OPERATOR HANDLE TILTED BACK IN THE SERVICE POSITION. IF THE SURFACE GRINDER IS NOT POSITIONED IN A STABLE CONFIGURATION, WITH ADEQUATE COUNTERWEIGHT PROPERLY SECURED, UNEXPECTED MOVEMENT CAN ALLOW THE SURFACE GRINDER TO FALL BACK TO THE WORK SURFACE. THE RESULT CAN BE PROPERTY DAMAGE AND/OR PERSONAL INJURY.

4) Using the 7/16 inch wrench, install the PN SG24-0230 rubber skirt around the outside perimeter surrounding the multi-accessory discs. Secure with the PN 15040700 cap screws and PN 49050000 washers. The original bumper and PN 27040800 cap screws can also be utilized as an alternative attachment method. The notches in the rubber skirt are provided as a means to compensate for multi-accessory attachment wear (if applicable). Adjust the location of the rubber skirt to provide the necessary clearance between it and the work surface. Improper clearance will accelerate skirt wear, FIGURE 2.

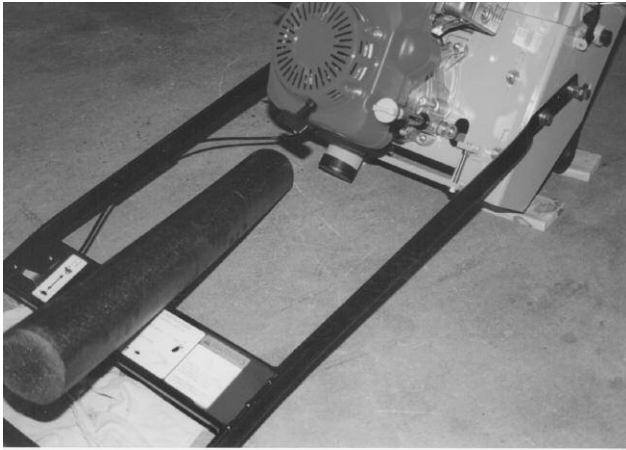

FIGURE 1

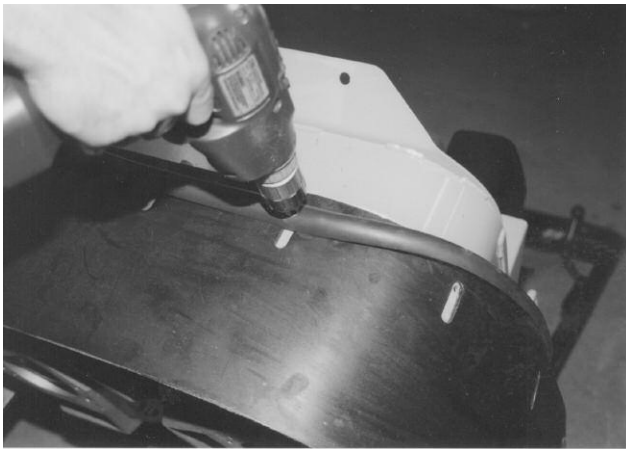

FIGURE 2

5) Using the 1/2 inch wrenches, the PN SG24-0350 rubber skirt is attached to the middle support member of the main frame. Proper installation will have the hose attach fitting that is riveted to the skirt facing the rear of the machine. The notches in the rubber skirt are provided as a means to compensate for multi-accessory attachment wear (if applicable). Adjust the location of the rubber skirt to provide the same clearance as with the PN SG24-0230 rubber skirt. The PN SG24-0370 skirt straps provide additional support for the rear skirt assembly. Properly secure with the PN 15050700 cap screws and PN 53050000 self locking nuts, FIGURE 3.

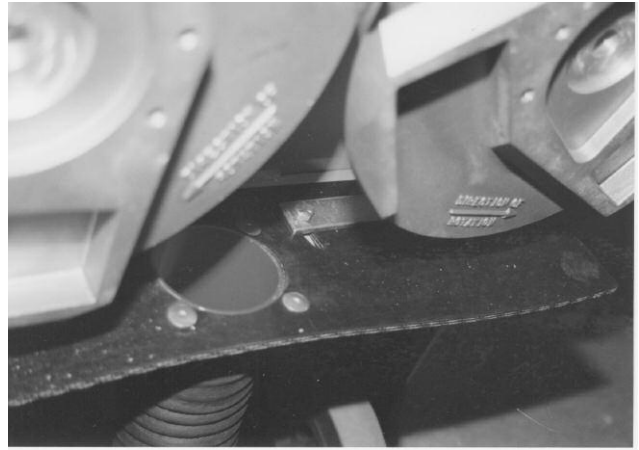

FIGURE 3

6) Assemble the two each, PN 56480000 hose clamps over the PN SG24-0380 vacuum hose. Install the vacuum hose over the vacuum hose attach fittings. Determine that the configuration minimizes potential kinks or depressions which can reduce the airflow. Secure the hose clamps tight with the screwdriver.

7) The PN SG24-1000 Safety and Dust Shield Assembly Kit can be removed by reversing the above procedure and reinstalling the original PN SG24-0220 bumper.

8) Return the Surface Grinder to its normal operating position.

9) If the Surface Grinder is powered by an engine, reconnect the engine spark plug wire. If powered by an electric motor and the machine is to be used immediately, reconnect the extension cord or Surface Grinder to the power source. Determine that the ON/OFF switch located on the operator handle is in the OFF position.



DANGER

UNEXPECTED MACHINE START UP CAN RESULT IN PROPERTY DAMAGE AND/OR PERSONAL INJURY.

Before Starting the Engine

FILLING THE ENGINE CRANKCASE WITH OIL.

Applications: SG24/G Series and SG24/GHP Surface Grinder

Note: The SG24/GHP Surface Grinder is shipped with oil in the engine crankcase and with the Propane cylinder empty. Units are test run to insure that the Propane conversion components are functioning properly. Regular gasoline powered units are selected at random at the factory and also test run. These units are shipped with oil in the engine crankcase. Fuel is drained from the fuel tank and will be marked accordingly by factory personnel.

Tools Required:

1 each, small, clean funnel

The SG24/G Series Surface Grinder is available equipped with a variety of industrial quality, gasoline and diesel engines. Engines are not normally preserviced at the factory (see note above) and will require the addition of oil in the crankcase before being placed in service. Consult the material supplied by the engine manufacturer for the engine that has been ordered with your Surface Grinder. Carefully review this material to become familiar with specific operating characteristics, recommendations and service requirements.

- 1) Determine the location(s) of both the oil filler and oil drain plug(s).
- 2) Wipe oil, dust and accumulated dirt from the filler plug area.
- 3) Using the funnel, fill the engine crankcase with a high grade motor oil. Consult the material supplied by the engine manufacturer for proper amount, weight and service classification.
- 4) Replace the oil filler plug and tighten. Wipe off any excess oil spilled on the engine crankcase and Surface Grinder.
- 5) Do not operate the engine unless proper oil level is maintained as per the material supplied by the engine manufacturer.

FILLING THE SG24/G SERIES ENGINE FUEL TANK.

Tools Required:

1 each, small, clean funnel



NEVER MIX OIL WITH GASOLINE. FOUR CYCLE ENGINES ARE NOT DESIGNED TO BE OPERATED WITH OIL MIXED WITH THE GASOLINE.

- 1) Determine the location of the fuel tank filler cap.
- 2) Carefully clean the filler cap and surrounding area to insure that no dirt or debris falls into the fuel tank. Remove the filler cap.
- 3) Using the funnel, fill the fuel tank with fresh, clean fuel according to the specifications outlined in the material supplied by the engine manufacturer. Do not overfill the tank or spill any fuel. If the fuel tank incorporates a screen mesh to prevent debris from falling into the tank, do not remove to increase the fill rate. Replace the filler cap. Wipe away any excess spilled fuel.



MANY FUELS ARE EXTREMELY FLAMMABLE. DO NOT SMOKE NEAR THE FUEL TANK. DO NOT FILL THE FUEL TANK WITH THE ENGINE RUNNING OR IF IT IS HOT. ALLOW AMPLE TIME BETWEEN EACH REFUELING FOR THE ENGINE TO COOL.

FILLING THE SG24/GHP PROPANE CYLINDER.

The SG24/GHP Surface Grinder is shipped from the factory with a Propane conversion kit for the Honda GXV340 engine and supplied with a standard 20 lb capacity Propane cylinder. The Propane conversion is performed by knowledgeable personnel licensed and/or certified to perform the conversion. A copy of the original licensing certificate is shipped with each machine. If the original certificate becomes destroyed or lost, contact the Customer Service Department for a duplicate. There is no charge for this service.

Empty Propane cylinders should always be filled according to established, industry standards by

qualified personnel. Cylinders should be tested for structural integrity according to industry standards and/or local code requirements by qualified personnel only.



DANGER

IMPROPER USE, HANDLING AND MAINTENANCE OF THE PROPANE CYLINDER CAN RESULT IN PROPERTY DAMAGE AND/OR PERSONAL INJURY. INSPECT THE CYLINDER, VALVE, FITTINGS, HOSES AND HARDWARE FOR DAMAGE BEFORE AND AFTER EACH USE. REPLACE ANY QUESTIONABLE COMPONENT WITH A FACTORY APPROVED REPLACEMENT ONLY. DO NOT ALLOW ANY PERSONNEL TO OPERATE A PROPANE CONVERTED ENGINE UNTIL PROPER AND/OR ADEQUATE INSTRUCTION HAS BEEN GIVEN WITH FULL COMPREHENSION.



DANGER

PROPANE IS AN EXPLOSIVE GAS. DO NOT SMOKE OR INTRODUCE AN OPEN FLAME IN OR NEAR THE PROPANE CYLINDER AT ALL TIMES WHEN FILLING, OPERATING/UTILIZING THE SURFACE GRINDER OR PERFORMING ANY MAINTENANCE.

Operation

THEORY OF OPERATION.

Application: All Models

The SG24 Series Surface Grinders operate on the principle of various multi-accessory attachments being utilized at rotational speeds to make direct contact with a work surface. Various types of multi-accessory attachments are secured to recesses provided in two, counterrotating, aluminum discs located on the bottom of the machine. The specific type of multi-accessory attachment utilized during the grinding process directly affects the type of material removed, the material removal rate and the resulting flatness and smoothness of the surface.

The grinding process is directly controlled by these

conditions:

- 1) The use of a suitable mechanism (multi-accessory attachment) of proper design and configuration to grind the work surface and remove material while delivering acceptable service life.
- 2) Sufficient static weight supporting the multi-accessory attachment to allow it to effectively penetrate the work surface and remove material.
- 3) Adequate horsepower capable of propelling the multi-accessory attachment against the work surface to deliver acceptable productivity rates.

Since no two materials are exactly alike, no two work surface materials can be penetrated and removed by the exact same method. The nature of the grinding process, along with operator experience, skill and common sense, would suggest that efficient and productive material removal is a matter of trial and error. Combinations of multi-accessory attachment type, condition, and feed rate are direct factors that will also determine the overall success of the job application.

MULTI-ACCESSORY ATTACHMENTS AND APPLICATIONS.

Application: All Models

While individual multi-accessory attachment design and configuration may vary, basic operational characteristics are identical: impact upon a work surface material and remove a percentage of the material. This common operational characteristic has led to the development of the following popular multi-accessory attachments:

Grinding Stones

Grinding stones are available in a number of grades, including: C06 extra coarse, C10 coarse, C24 medium, C80 fine and C120 super fine grade. All stones incorporate silicon carbide as the abrasive medium and employ a clay binder as the matrix material. Vitrified type stones utilize an oven baking process that produces greater service life over other manufacturing processes. As the clay material wears away, it exposes new, sharp, edges of the imbedded silicon carbide material. All stones have the identical 2" x 2" X 4" dimensions and are secured to the machine by the use of a hardwood wedge, FIGURE 4.



FIGURE 4

The designation system for the grinding stones utilizes a system similarly utilized for most abrasive products: the larger the number, the finer the grain structure and usually, the smoother the resulting finish.

- a) The C06 and C10 coarse grade stones are the most popular utilized stones and result in maximum material removal rates. They are utilized for general grinding and the removal of trowel marks, high spots and rough sections on concrete surfaces. The average service life is approximately 4 to 10 hours.
- b) The C24 medium grade stone will result in lower material removal rates. It is utilized for finer finish grinding of concrete and rough grinding on terrazzo and other types of stone floor configurations. The average service life is approximately 6 to 10 hours.
- c) The C80 fine grade stone will result in still lower material removal rates. It is utilized for polishing concrete and medium grinding on terrazzo and other types of stone floor configurations with a water/slurry mixture only. The average service life is approximately 8 to 20 hours.
- d) The C120 super fine grade stone will result in the lowest material removal rates. It is utilized for final polishing on terrazzo and other types of stone floor configurations with a water/slurry mixture only. The average service life is approximately 40 to 75 hours.

Tungsten Carbide Grinding Block

This multi-accessory attachment is most often utilized on larger concrete grinding projects where increased production and service life are required. The block utilizes tungsten carbide balls approximately 1/16 inch diameter that are deposited in a molten matrix material

during the manufacturing process at a controlled rate. The end effect is a multi layer deposit of tungsten carbide balls in the matrix material. As the softer matrix material wears with use, it exposes a new layer of fresh tungsten carbide balls to continue the grinding process. The tungsten carbide grinding block is considerably more aggressive than the C10 silicon carbide grinding stone. With the ability to renew itself during usage, the normal life expectancy for this accessory can approach several hundred hours. The nominal dimensions for the tungsten carbide grinding block is 2" x 2" x 4" and is secured to the machine with a hardwood wedge, FIGURE 5.



FIGURE 5

Scarifier Blocks

These multi-accessory attachments are comprised of flails and spacer washers secured in a rigid steel case, FIGURE 6. Rotation of the two multi-accessory discs causes the flails to impact against the work surface with a variety of results. Scarifier blocks are secured to the machine with hardwood wedges.

Several factors directly affect the selection of a flail design for a specific job application:

- a) The type and amount of material to be removed from the work surface. Materials of higher yield and tensile strengths along with the actual volume of material to be removed will generally be the first factors under consideration.
- b) Purchase cost versus service life. The original purchase cost of plain, heat treated steel flails must be compared against the substantially higher costs of the tungsten carbide insert flails. In turn, these costs must be compared to anticipated service life. All flails will eventually wear to the point of requiring replacement.

The amount of unproductive time spent to replace worn flails on a job can be substantially greater than the actual replacement cost of many flails. It then becomes a balance between purchase cost, productivity, service life and labor cost.

c) Surface finish and texture. The finest grained surface finish available from the scarifying process is comparable to a "swept or broomed" like finish. If a smooth, flat finish is desired, the scarifying process must be followed with a grinding or polishing type process. Many job requirements may call for large amounts of material to be removed, but followed with additional specifications requiring a finer surface finish or texture. Many times these jobs dictate the use of an aggressive flail configuration because of productivity and cost considerations. Less aggressive flail configurations can then be utilized for the final finishing sequence. Generally speaking, the more aggressive the flail configurations, the more coarse the resulting finish and texture.

Many flail configurations are available to meet a wide variety of job applications and surface material specifications. To give additional perspective to each configuration, a rating system of 1 to 10 (10 being highest) has been devised.



FIGURE 6

Star Flail

The star flail is manufactured from high carbon steel that is thoroughly hardened for additional service life. It is highly effective for light cleaning or scarifying and delivers a finer surface finish texture, FIGURE 7.

Suggested applications:

- 1) Removal of thin coatings and encrusted accumulations.
- 2) Cleaning concrete and asphalt surfaces.
- 3) Removing thick material build-ups of greases, paints, oils, vegetable powders and some resins from floors.
- 4) Light scarifying prior to the application of coatings, toppings or sealers.



FIGURE 7
COST 1
PRODUCTIVITY 3
SERVICE LIFE 1

The star flail should be replaced when the outside diameter is worn to approximately 1-5/16 inch or the inside diameter elongates to approximately 3/4 inch.

Beam Flail

The beam type flail is manufactured from high carbon steel that is thoroughly hardened for additional service life. It is highly effective for scabbling or scarifying and delivers medium to coarse surface finish texture, FIGURE 8.

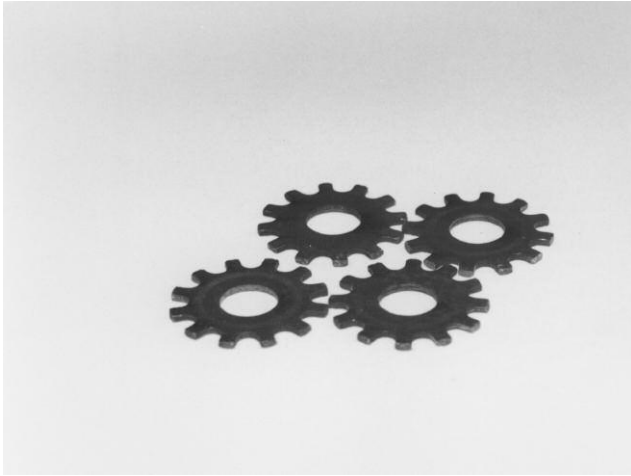

FIGURE 8

Suggested applications:

- 1) Medium duty asphalt and concrete scarifying.
- 2) Descaling steel decks.
- 3) Removing thick material build-ups of greases, paints, oils, vegetable powders and some resins from floors.
- 4) Dried, fully cured, carpet and tile adhesive removal.

COST 1
PRODUCTIVITY 5
SERVICE LIFE 2

The beam flail should be replaced when the outside diameter is worn to approximately 1-5/16 inch or the inside diameter elongates to approximately 3/4 inch.

Pentagonal Flail

The pentagonal type flail is manufactured from high carbon steel that is thoroughly hardened for additional service life. Each section of the five sided design features a small, tungsten carbide insert that is held in position with copper brazing. It is highly effective for scabbling or scarifying and delivers medium to coarse finish texture, FIGURE 9.



FIGURE 9

Suggested applications:

- 1) Heavy duty asphalt and concrete scarifying.
- 2) Heavy duty descaling of steel decks.

The pentagonal flail is designed for more aggressive and rapid removal of a surface in comparison to the beam flail. The addition of the tungsten carbide inserts contributes to its long service life and higher production rates. The use of tungsten carbide is also the main reason for the cost differential between it and the other flails. The design configuration yields a rather coarse surface finish and texture. For many job applications, this finish and texture will be satisfactory. Some applications may require an additional smoothing process. If the resulting surface finish is too coarse to meet specifications, it can be smoothed with the use of the star or beam flail.

COST 10
PRODUCTIVITY 8
SERVICE LIFE 10

The pentagonal flail should be replaced when two successive tungsten carbide inserts break off or the inside diameter elongates to approximately 3/4 inch. In service, the flail body will wear much faster than the tungsten carbide inserts. The copper brazing used to weld the inserts into the body can fail and an insert break off. The flail can still be used in service. It will just wear a little faster and more uneven in that particular area. As a general rule, a pentagonal flail can be utilized until body wear will no longer support the tungsten carbide inserts.

Spacer Washer

Spacer washers are stamped from high carbon steel and heat treated for additional service life, FIGURE 10.

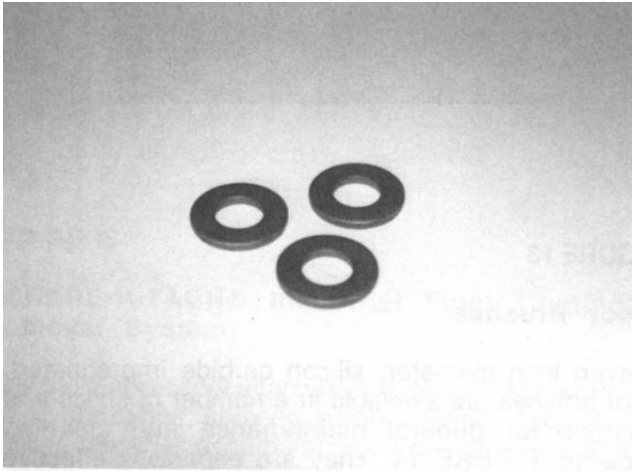

FIGURE 10

Spacer washers serve the following function:

- 1) Reduces the number of flails required to be mounted on the scarifier block, thus reducing purchase and operational costs.
- 2) Arrange the flails in a sequence or pattern that minimize "blind" or "open" spots. Normally, at least one spacer washer is inserted between two consecutive flails. A scarifier block set up with only star, beam or pentagonal flails will not penetrate the work surface at satisfactory rates. This configuration will minimize the hammering or impact action of the flails.

Variances in material thickness and manufacturing processes can affect the final thickness of both flails and spacer washers. Because of this occurrence, trial and error is important for assembling flails and spacer washer on the scarifier block. By mixing and matching flails and spacer washers of specific thicknesses, the required number of components can be assembled on a block in a minimum amount of time.



DANGER

USE ONLY FACTORY SUPPLIED SPACER WASHERS ON THE SCARIFIER BLOCK. OTHER WASHER TYPES AND/OR CONFIGURATIONS CAN PRODUCE ABNORMAL WEAR AND ELONGATION,

RESULTING IN COMPLETE SEPARATION FROM THE SCARIFIER BLOCK. INADVERTENT SPACER WASHER SEPARATION CAN LEAD TO PROPERTY DAMAGE AND/OR PERSONAL INJURY.

Scarifier Block Bushing

Scarifier block bushings are designed to be discarded whenever the flails are replaced, FIGURE 11. Normal wear should be uniform about the bushing circumference.



FIGURE 11

Uneven bushing wear would suggest the following problems:

- 1) Inadequate free play exists between the flails/spacer washers and the scarifier block case. If the flails and spacer washers do not have complete freedom of movement, they will not be capable of properly rotating about the scarifier block bushing. The result is bushing wear usually confined to two locations that are 180 degrees apart. Variances in flail and spacer washer thicknesses affect free play when assembled on the scarifier block. Because free play is also created during the scarifying process due to actual flail and spacer washer wear, a certain amount of "tightness" can sometimes be tolerated without affecting the service life of the bushings and flails. The specific amount of "tightness" can usually be determined through trial and error. If the flails and spacer washers appear too tight on the scarifier block, remove an appropriate flail or washer and reassemble the block. If a short, operational test indicates normal component wear patterns, the apparent problem has been solved. A general rule for consideration: it is better to have the flails and spacer washers a "little too loose than a little too tight".

2) Mixing both worn and new flails on the scarifier block. Proper flail action against the work surface material requires that the flails be of the same approximate dimensions. Flails with various inside and outside dimensions will not impact the work surface material with the same intensity and deliver the same results. Flail bushing wear is directly proportional to the amount of force it must supply against each individual flail. When a bushing can no longer supply adequate force against the flails, it will break, allowing the flails to be hurled against the inside of the Surface Grinder frame. The more aggressive flails require greater forces to keep them contained on the block. These forces, in turn, create faster and/or uneven bushing wear rates.

Because scarifier bushings are a critical component of the actual scarifying process, it is important that each bushing be inspected on a regular basis to determine proper structural integrity.

Wire Brushes

Typical applications include light scarifying and cleaning of concrete, asphalt, steel and tile surfaces. Wire brushes are secured to the machine with hardwood wedges, FIGURE 12.

Wire brushes are available in a number of flat wire sizes and resulting configurations. With continuous use, the flat wire will take a "set" that can limit effectiveness and overall productivity, FIGURE 13. For best results, flat wire brushes should be rotated end for end in the aluminum multi-accessory discs a minimum of once for every one hour of operation. External weight applied to the Surface Grinder will not normally increase productivity rates and only accelerate flat wire wear rates.



FIGURE 12

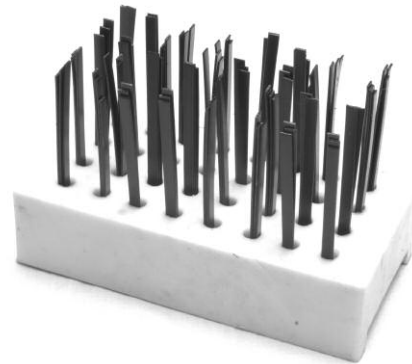

FIGURE 13

Floor Brushes

Eleven inch diameter, silicon carbide impregnated, floor brushes are available in a number of styles and designs for general maintenance and cleaning projects, FIGURE 14. They are especially effective cleaning soiled concrete floors with the addition of water soluble solvents. These types of brushes are directly mounted to the multi-accessory discs with the included 1/2 inch x 2 inch long Grade 5 cap screws. A kidney shaped drive plate is provided on the back side of the brush. This drive plate fits into a recess provided in the multi-accessory disc, FIGURE 15. To maximize bristle service life, it is recommended that the silicon impregnated brushes be rotated between multi-accessory discs a minimum of once for every one hour of operation.



FIGURE 14



FIGURE 15

SCRAPE-R-TACH® Industrial Floor Coatings Removal System

This multi-accessory attachment is designed to remove many urethanes, epoxies, paints, mastics and other, similar material accumulations from concrete floor surfaces, FIGURE 16. Each assembly utilizes two tungsten carbide inserts set at a precise angle. The rotating inserts "cut and shave" against the work surface material with a "scraping" action that removes materials with highly productive results. To increase the effectiveness of the inserts, the scraper block design incorporates a Lord® type rubber mount that helps absorb damaging shocks while allowing the inserts to more easily follow local variations in the surface contour. Units are secured to the machine with hardwood wedges.



FIGURE 16

The productivity of the product is directly dependent upon the yield and tensile strength of the material

being removed. Material thickness has also shown to have a direct effect on overall productivity. For example, the SCRAPE-R-TACH system is a highly productive method for removing thick paint accumulations from factory floors. Production rates of up to several hundred square feet per hour can be realized. However, many thin film (ie: 5 mill thickness and thinner) urethane coatings present a much more difficult removal problem. Since removal rates are also directly affected by applied down force, up to 300 lbs of external weight can be added to the Surface Grinder to increase productivity. Cement blocks or stacked bags of cement make excellent weights and can be secured with "bungy" cords or other means with the provided holes in the top cover, FIGURE 17.



FIGURE 17

Each insert provides 8 scraping edges. As an edge becomes dull and worn, the insert can be turned and reinstalled to expose a new, sharp edge, FIGURE 18. When all 4 edges of one side become worn and dull, the insert can be turned over to expose an additional 4 edges.

Many materials such as adhesives, rubber deposits and mastics have the tendency to extrude or smear rather than shear from the concrete floor material. The occurrence is also aggravated by higher ambient temperatures. This problem can be significantly reduced with the addition of various amounts of water or a water saturated, fine sand combination placed on the floor. The use of the Part Number SG24-1000 Safety and Dust Shield Assembly with the Surface Grinder is highly recommended to contain the water/sand slurry mixture from damaging surrounding walls and other vertical surfaces, FIGURE 19.

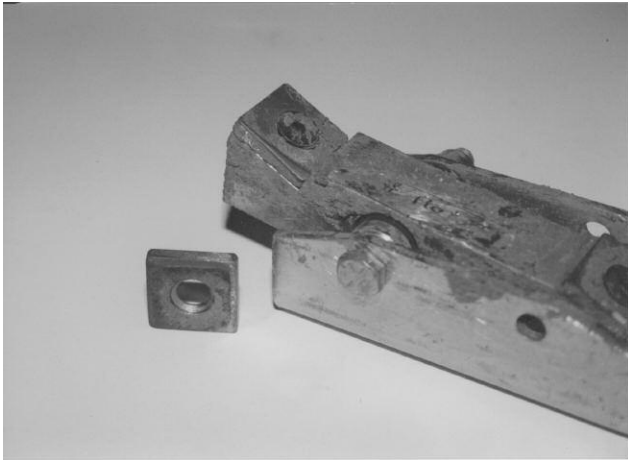

FIGURE 18

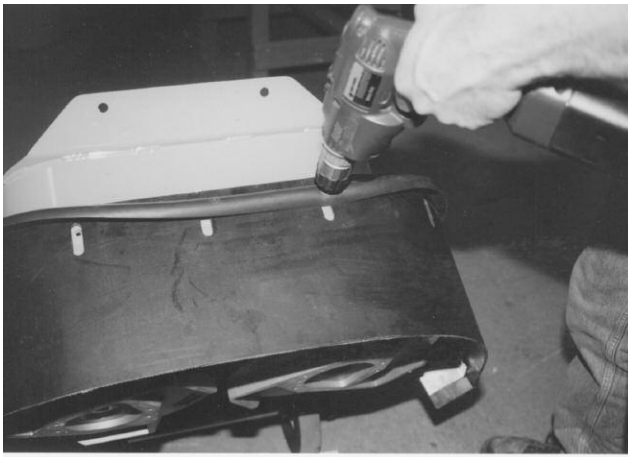

FIGURE 19

To index the tungsten carbide insert, proceed as follows:

Tools required:

- 1 each, 5/32 Allen wrench
- 1 each, 7/16 inch wrench

1) Clean the SCRAPE-R-TACH unit with a suitable safety solvent to remove excess material build-up. Remove as much foreign material as possible from the female hexagon socket area of the cap screw. This will allow the wrench to make full contact and maximize the torque transfer to the cap screw.

CAUTION

Follow all safety precautions for the safety solvent.

2) Remove the cap screw from the unit. Clean the newly exposed areas of the insert and SCRAPE-R-TACH unit with the safety solvent. Clean and inspect the threaded holes found in older units for excess wear. New style SCRAPE-R-TACH units feature a through hole design.

3) Index the insert to expose a new edge. Reinstall the cap screw (lock washer and hexagon nut on new style units) and apply a torque value that properly seats the insert firmly against the body of the unit.

CAUTION

An insufficient seating torque value will allow the insert to become loose from the unit body, resulting in premature component wear and improper scraping action. An excessive torque value will strip the threads of the cap screw or unit body.

4) Determine that the unit body is free to rotate about the 5/16 inch diameter cap screw that retains the body to the unit. A body that does not freely rotate indicates that a material build-up exists between the rubber mount and retaining cap screw exits. This build-up must be removed by disassembling the body from the unit and cleaning all contact areas with the safety solvent, FIGURE 20.

The SCRAPE-R-TACH system is designed to be installed with the edge of the tungsten carbide inserts facing the direction of rotation. Markings are provided to indicate proper direction of rotation.

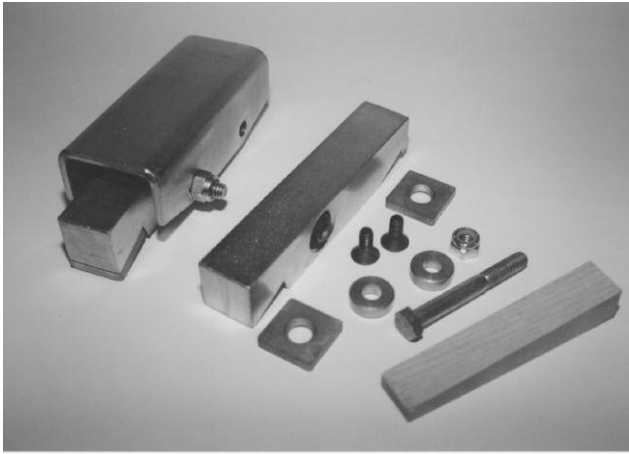

FIGURE 20



CAUTION

Installing the SCRAPE-R-TACH system with the tungsten carbide inserts facing opposite the rotation direction will not deliver satisfactory material removal rates and result in premature component wear requiring early replacement.

Multi-Segmented, Dry Diamond Disc

Many times increased concrete removal rates can be achieved with the use of multi-segmented, dry diamond discs, FIGURE 21. These discs are designed to operate dry or can also be utilized with water. If the wet option is chosen, an external source for providing water must be devised. No provision for water use is provided with the Surface Grinder. Typical discs are approximately 10 inches in diameter and feature up to 20 diamond segments that are welded or brazed to each assembly.

To install the multi-segmented, dry diamond discs, the standard, aluminum, multi-accessory discs are first removed from the Surface Grinder. The diamond discs fasten directly to the gimbal heads with 3/8 inch diameter x 1 inch long Allen head cap screws, FIGURE 22. The rear wheel assembly is then placed in the lowest position to compensate for the thickness variance of the diamond disc, FIGURE 23.



FIGURE 21

To maximize the service life of the diamond segments, it is recommended that the blades be rotated between gimbal heads a minimum of once for every 8 hours of operation.

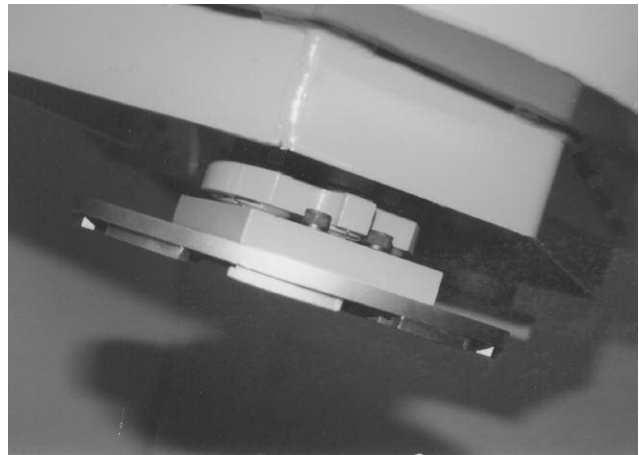

FIGURE 22

Diamond Segment Block

The diamond insert block is designed to compliment the multi-segmented diamond disc where a quick changeover feature to other attachments is desired.

Diamond segments are retained into a steel block assembly and deliver up to 5 times greater productivity rates than the silicon carbide stones, FIGURE 24. The design resists clogging while delivering a conservative service life up to 15 times longer than the stones. Diamond is the ideal choice for larger concrete removal projects and the removal of epoxies, paints and many thin film coatings.

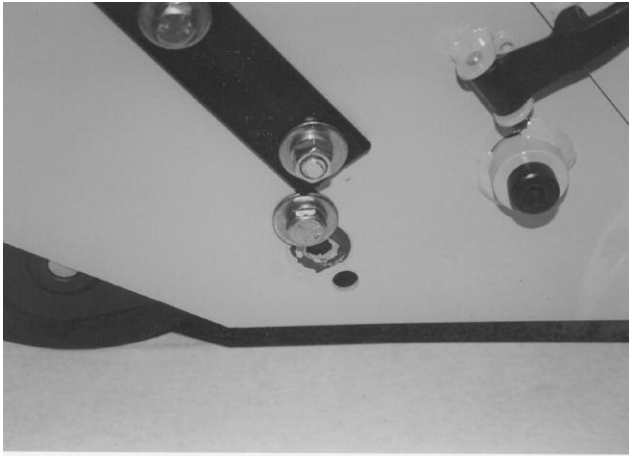

FIGURE 23

The concept is especially useful for removing a thin layer of concrete in final preparation for a new coating application. Can be used in both wet and dry job applications. Worn inserts are easily replaced in a matter of seconds. Service life is dependent upon many variables, but can approach 35,000 square feet per set, making it a cost efficient solution for many job applications.

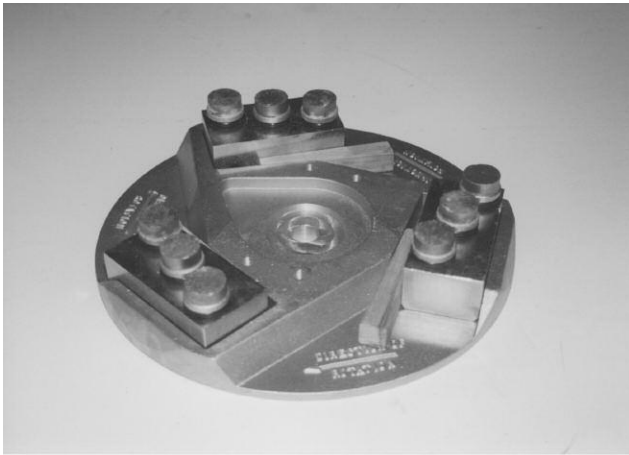

FIGURE 24

INSTALLING A MULTI-ACCESSORY ATTACHMENT (not including multi-segmented, dry diamond discs) IN THE COUNTERROTATING DISCS.

Application: All Models

Tools required:

1 each, small hammer

Parts required:

6 each, PN SG24-1800 Mounting Wedge

SG24 GRINDER FORM GOM3259601, VERSION 1.2, AUTHORIZATION: DVR, PAGE: 24

 **DANGER**

WHEN INSTALLING A MULTI-ACCESSORY ATTACHMENT ON THE SURFACE GRINDER ALWAYS WEAR THE APPROPRIATE SAFETY EYEWEAR AND APPAREL TO MINIMIZE THE POTENTIAL FROM FLYING DEBRIS. FLYING DEBRIS CAN RESULT IN PROPERTY DAMAGE AND/OR PERSONAL INJURY.

1) If the Surface Grinder is powered by an engine, disconnect the spark plug wire. If powered by an electric motor, properly disconnect the extension cord or Surface Grinder from the power source

2) Tilt the Surface Grinder back until the operator handle comes in contact with the surface. The Surface Grinder may not be in a stable position in this configuration. To minimize the possibility of property damage and/or personal injury, properly secure an appropriate weight to the handle for added stability. Other means can also be utilized to support the frame and provide proper machine stability. Appropriate wheel chocks are also recommended, FIGURE 25.

 **DANGER**

EXERCISE EXTREME CAUTION WHEN WORKING NEAR OR UNDER THE SURFACE GRINDER WITH THE OPERATOR HANDLE TILTED BACK IN THE SERVICE POSITION. IF THE SURFACE GRINDER IS NOT POSITIONED IN A STABLE CONFIGURATION, WITH ADEQUATE COUNTERWEIGHT PROPERLY SECURED, UNEXPECTED MOVEMENT CAN ALLOW THE SURFACE GRINDER TO FALL BACK TO THE WORK SURFACE. THE RESULT CAN BE PROPERTY DAMAGE AND/OR PERSONAL INJURY.

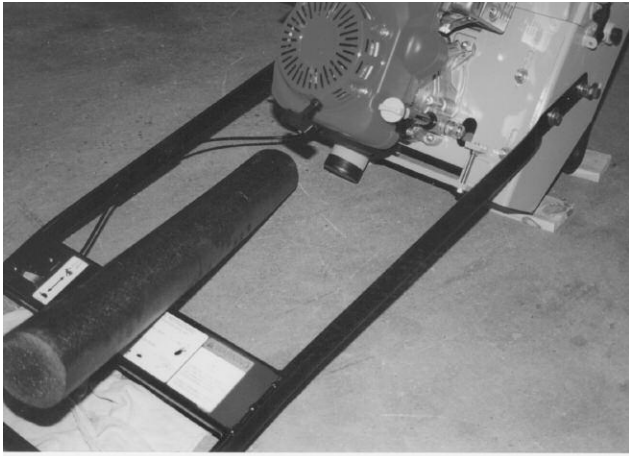

FIGURE 25

3) Mount the multi-accessory attachment into the slots provided in the multi-accessory discs. If the attachment is directional in design, determine that its mounting position in the disc allows for proper operation.

4) Force an SG24-1800 Mounting Wedge into the area between the multi-accessory attachment and the inside rib of the aluminum disc by hand. The straight side of the mounting wedge contacts the multi-accessory attachment. The angled side of the mounting wedge contacts the rib of the disc, FIGURE 26. An improper mounting configuration is depicted in FIGURE 27.

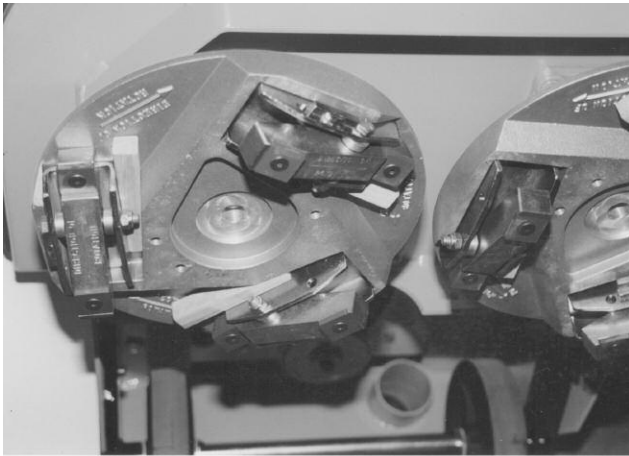

FIGURE 26



FIGURE 27

DANGER

DO NOT OPERATE THE SURFACE GRINDER WITH THE SG24-1800 MOUNTING WEDGES IN AN IMPROPER MOUNTING CONFIGURATION. MOUNTING A WEDGE BETWEEN THE MULTI-ACCESSORY ATTACHMENT AND THE OUTSIDE RIB OF THE ALUMINUM DISC CAN ALLOW THE WEDGE TO COME IN DIRECT CONTACT WITH A VERTICAL WALL AND/OR FLOOR OBSTRUCTION. SUCH OCCURRENCE CAN RESULT IN LOSS OF MACHINE CONTROL, PROPERTY DAMAGE AND/OR PERSONAL INJURY.

BEFORE OPERATING THE SURFACE GRINDER WITH ANY MULTI-ACCESSORY ATTACHMENT, DETERMINE THAT NO PORTION OF THE ATTACHMENT AND/OR MOUNTING WEDGE EXTENDS BEYOND THE NORMAL PERIMETER OF THE ALUMINUM DISC.

5) Using the hammer, strike the wider side of the mounting wedge with controlled, direct blows to firmly seat the multi-accessory attachment into the aluminum disc. Usually one or two direct blows will be sufficient to properly retain the attachment.

CAUTION

Do not apply excessive impact force to the mounting wedge to cause splitting. Once the multi-accessory attachment is seated in the aluminum disc, further impact force on the wedge will not increase the seating force.



CAUTION

Improper seating force created by an excessive blow to the mounting wedge will not allow the attachment to properly release from the aluminum disc if direct contact with a foreign object is made. Such occurrence can result in property damage and/or personal injury. The correct seating force for a specific job application is that which is sufficient to retain the attachment, yet still allows it to release from the aluminum disc when direct contact with a foreign object is made.

6) Determine that the multi-accessory attachment is in full contact with the aluminum disc. If not in proper contact, refer to REMOVING A MULTI-ACCESSORY ATTACHMENT (not including multi-segmented, dry diamond blades) FROM THE COUNTERROTATING DISCS for proper removal procedures.

7) Return the Surface Grinder to its normal operating position.

8) If the Surface Grinder is powered by an engine, reconnect the engine spark plug wire. If powered by an electric motor and the machine is to be used immediately, reconnect the extension cord or Surface Grinder to the power source. Determine that the ON/OFF switch located on the operator handle is in the OFF position.



DANGER

UNEXPECTED MACHINE START UP CAN RESULT IN PROPERTY DAMAGE AND/OR PERSONAL INJURY.

REMOVING A MULTI-ACCESSORY ATTACHMENT (not including multi-segmented, dry diamond discs) FROM THE COUNTERROTATING DISCS.

Application: All Models

Tools required:

- 1 each, small hammer
- 1 each, drift punch or small, pry bar



DANGER

WHEN REMOVING A MULTI-ACCESSORY ATTACHMENT FROM THE SURFACE GRINDER, ALWAYS WEAR APPROPRIATE SAFETY EYEWEAR AND APPAREL TO MINIMIZE THE POTENTIAL FROM FLYING DEBRIS. FLYING DEBRIS CAN RESULT IN PROPERTY DAMAGE AND/OR PERSONAL INJURY.

1) If the Surface Grinder is powered by an engine, disconnect the spark plug wire. If powered by an electric motor, disconnect the extension cord or Surface Grinder from the power source.

2) Tilt the Surface Grinder back until the operator handle comes in contact with the surface. Follow the instructions for this procedure as outlined in INSTALLING A MULTI-ACCESSORY ATTACHMENT (not including multi-segmented, dry diamond blades) IN THE COUNTERROTATING DISCS.

3) The multi-accessory attachment can be removed by both the use of a drift punch or small, pry bar. If utilizing the drift punch, strike the narrow end of the mounting wedge with controlled, direct blows until the attachment is released from the aluminum disc. If utilizing the pry bar, position the bar between the aluminum disc and the attachment. Use controlled, direct blows to the bar in order to force the attachment loose from the aluminum disc, FIGURE 28.



FIGURE 28



CAUTION

Do not utilize excessive force when removing a multi-accessory attachment with the pry bar. Excessive force can result in damage to the aluminum disc. Proper removal techniques by both methods will result in minimal damage to the aluminum disc.

4) Return the Surface Grinder to its normal operating position.

5) If the Surface Grinder is powered by an engine, reconnect the spark plug wire. If powered by an electric motor and the machine is to be used immediately, reconnect the extension cord or Surface Grinder to the power source. Determine that the ON/OFF switch located on the operator handle is in the OFF position.



DANGER

UNEXPECTED MACHINE START UP CAN RESULT IN PROPERTY DAMAGE AND/OR PERSONAL INJURY.

TRANSPORTING THE SURFACE GRINDER.

Application: All Models

The Surface Grinder has an operational weight that prohibits one person from loading and/or unloading it alone by conventional, physical efforts.



DANGER

DO NOT ATTEMPT TO LIFT THE SURFACE GRINDER UP INTO A TRANSPORTATION VEHICLE WITH THE USE OF ONE PERSON ALONE. DO NOT ATTEMPT TO LOWER THE SURFACE GRINDER FROM A TRANSPORTATION VEHICLE WITH THE USE OF ONE PERSON ALONE. LIFT AND/OR LOWER THE SURFACE GRINDER ONLY BY THE USE OF A POWER TAILGATE UNIT, A SUITABLE HOIST UNIT OF PROPER CAPACITY AND/OR CONFIGURATION OR BY THE USE OF A PROPER QUANTITY OF PERSONNEL IN PROPER PHYSICAL CONDITION.

1) A lifting bail device can be used to facilitate lifting by

a mechanical device incorporating a chain and suitable attachment device. The location of the lifting bail may not always locate the exact position of the center of gravity for the Surface Grinder. Lifting handles are also provided on both sides of the transmission case. These handles can be utilized by personnel whenever lifting/lowering the Surface Grinder or as attachment points for a chain sling whenever a suitable hoisting device is utilized, FIGURE 29.



DANGER

EXERCISE EXTREME CAUTION WHEN UTILIZING A MECHANICAL DEVICE FOR LIFTING THE SURFACE GRINDER. UTILIZE THE MECHANICAL DEVICE IN ACCORDANCE TO BOTH ITS STATED STATIC AND DYNAMIC LOADING ENVELOPES. DO NOT UTILIZE THE MECHANICAL DEVICE UNTIL THIS INFORMATION IS PROPERLY KNOWN AND UNDERSTOOD BY ALL APPLICABLE PERSONNEL. FAILURE TO PROPERLY UTILIZE THE MECHANICAL DEVICE CAN RESULT IN PROPERTY DAMAGE AND/OR PERSONAL INJURY.

2) When transporting the Surface Grinder on a motor vehicle, the fuel tank breather vent (if so equipped) must be completely closed to eliminate the accidental seepage of fuel and resulting potential fire and environmental hazards. If the engine is Propane converted, the cylinder should be removed from the Surface Grinder and all valves, hoses, fittings and related hardware be inspected for proper security and leaks. Transport the Propane cylinder in accordance to all local, State and Federal regulations. Properly secure and store the Propane cylinder to minimize the possibility of property damage and/or personal injury.

3) To minimize the possibility of damage to the Surface Grinder, always transport in its normal, upright position. All equipment must be secured in/on vehicles with suitable strapping or tie-downs. Personnel should not be transported in the same compartment as equipment and fuel supplies. Consult applicable OSHA, AGA, CGA, etc. regulations for the proper transportation of Propane and other, flammable gases.

ADJUSTING THE OPERATOR HANDLE HEIGHT.

Application: All Models

The SG24 Series Surface Grinder incorporates a handle that can be adjusted to compensate for variances in operator heights. Three adjustment

heights are provided. Correct handle height can increase overall machine productivity and reduce operator fatigue.



FIGURE 29

Tools Required:

1 each, 3/4 wrench or suitable alternative.

1) Using the wrench, loosen the 1/2 inch hexagon nuts from the stud assemblies that retain the handle to the main frame.

2) Using the wrench, remove the 1/2 inch cap screws that retain the handle in position on the main frame.



DANGER

EXERCISE EXTREME CAUTION WHEN REMOVING THE RETAINING CAP SCREWS FROM THE MAIN FRAME. WHEN THE FINAL CAP SCREW IS REMOVED, THE HANDLE IS PROVIDED WITH NO EXTERNAL SUPPORT AND WILL IMMEDIATELY DROP TO THE FLOOR. SUCH OCCURRENCE CAN RESULT IN PROPERTY DAMAGE AND/OR PERSONAL INJURY.

3) Reposition the operator handle in the desired location that aligns the hole in the handle with the threaded hole in the main frame. Replace the 1/2 inch hexagon cap screws and properly tighten with the wrench, FIGURE 30.

4) Using the wrench, properly tighten the 1/2 inch

hexagon nuts on the stud assemblies that retain the handle to the main frame.



FIGURE 30

STARTING THE SG24/E SERIES ELECTRICALLY POWERED SURFACE GRINDER ON THE JOB SITE.

1) Position the Surface Grinder on a flat and level surface of firm foundation.

2) Determine that the ON/OFF switch located on the operator handle is in the OFF position.



DANGER

UNEXPECTED MACHINE START UP CAN RESULT IN PROPERTY DAMAGE AND/OR PERSONAL INJURY.

3) Select the appropriate operating voltage for the electric motor. The motor is designed to operate from a clean, 20 ampere, 115 VAC, 60 Hz nominal or a clean, 10 ampere, 230 VAC, 60 Hz nominal power source. A clean power source refers to the amperage available on the individual electrical circuit selected. Additional electrical products already utilizing the same circuit will reduce the available amperage, resulting in starting and operational difficulties.

A voltage switch (115/230 VAC, 60 Hz) is provided on the motor. For added security, the voltage switch can be locked in position with a combination or keyed lock with an extended shank length, FIGURE 31.



CAUTION

Operating the Surface Grinder from a power source of improper voltage and amperage will result in unreparable damage to the electric motor and related controls.



FIGURE 31

4) Providing proper voltage and amperage levels to the electric motor is essential to obtain maximum productivity and service life. Low voltage and amperage levels will cause the motor to overheat. The motor is equipped with automatic thermal protection device that will stop it before major internal damage can result. After the motor has cooled to an acceptable temperature level, the switch must be manually activated to restart, FIGURE 32.

To minimize the voltage drop to the motor, all extension cords should be copper stranded, 8 AWG or larger. A NEMA 6-20R twist lock type receptacle is provided with the SG24/E Series Surface Grinder as a standard accessory. The twist lock feature allows the extension cord to be pulled by the Surface Grinder without becoming detached. Wire the NEMA 6-20R receptacle to the appropriate extension cord that will be coupled to the NEMA 6-20P plug provided on the Surface Grinder, FIGURE 33.

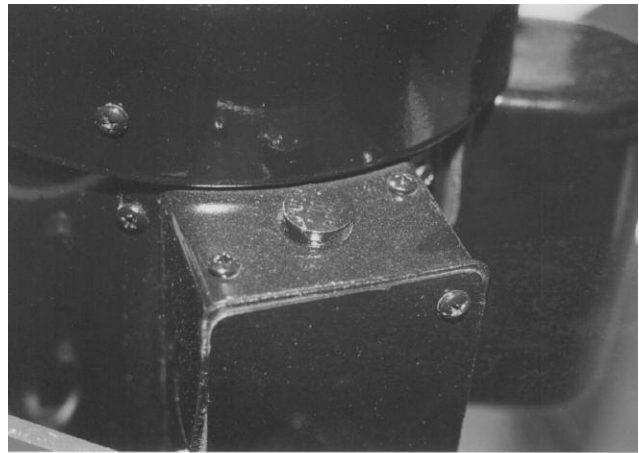

FIGURE 32

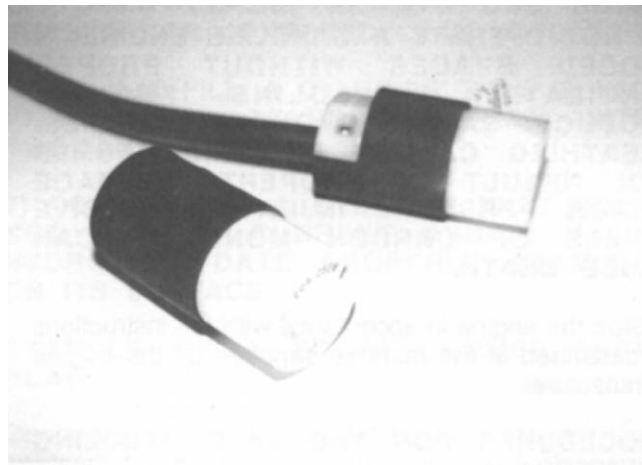

FIGURE 33



DANGER

PROPERLY INSPECT ALL EXTENSION CORDS AND WIRING DEVICES FOR STRUCTURAL INTEGRITY. DO NOT UTILIZE A CORD WITH A WORN OR CUT OUTER JACKET MATERIAL. DO NOT UTILIZE A CORD WITH EXPOSED INNER WIRES OR INSULATION MATERIAL. DO NOT UTILIZE A CORD THAT HAS BEEN REPAIRED WITH ELECTRICAL TAPE. USE OF AN EXTENSION CORD OF IMPROPER STRUCTURAL INTEGRITY CAN RESULT IN PROPERTY DAMAGE AND/OR PERSONAL INJURY.



DANGER

ALL ELECTRICAL WIRING MUST BE INSTALLED AND/OR APPROVED IN ACCORDANCE TO LOCAL ELECTRICAL CODES AND PRACTICES. AN IMPROPER WIRING INSTALLATION CAN RESULT IN PROPERTY DAMAGE AND/OR PERSONAL INJURY.

5) Determine that the power outlet to be utilized is properly grounded. This can be accomplished with proper testing equipment and procedures. If there are any questions regarding the suitability of a specific power outlet, contact the Customer Service Department for assistance BEFORE utilizing the Surface Grinder. There is no charge for this service. A qualified electrician can also be consulted. If a 115 VAC power outlet is selected, it is recommended that a properly tested, externally mounted, ground fault circuit interrupter (GFCI) be utilized at all times as an additional safety precaution. Ground fault circuit interrupters are not available for operation on 230 VAC, FIGURE 34.



FIGURE 34



DANGER

FOR MAXIMUM PROTECTION AGAINST A FAULT, ALWAYS CONFIGURE THE GROUND FAULT CIRCUIT INTERRUPTER TO BE PLUGGED INTO THE EXTENSION CORD. A CONFIGURATION WITH THE GROUND FAULT CIRCUIT INTERRUPTER PLACED BETWEEN THE POWER SOURCE AND THE EXTENSION CORD WILL NOT AFFORD MAXIMUM PROTECTION AGAINST A POTENTIAL FAULT.

SG24 GRINDER FORM GOM3259601, VERSION 1.2, AUTHORIZATION: DVR, PAGE: 30

6) Couple the NEMA 6-20R receptacle and the NEMA 6-20P plug together.

7) Grasp the operator handle with firm gripping. When starting the electric motor, apply a down force directly to the operator handle to help reduce the amount of machine weight against the work surface. Turn the ON/OFF switch to the ON position. Reduce the amount of applied down force on the operator handle as the electric motor attains its operational speed.

When operating on 115 VAC, the electric motor will require additional starting time to help compensate for the additional starting amperage requirement. This time is usually within two seconds of activating the ON/OFF switch.

8) The SG24/E Series electrically powered Surface Grinder is not equipped with a centrifugal clutch assembly. The electric motor is directly coupled to the multi-accessory discs by a V-belt/spur gear transmission.



DANGER

AS SOON AS THE ELECTRIC MOTOR HAS STARTED, THE OPERATOR MUST BE IN A POSITION TO ASSUME DIRECT AND FULL CONTROL OF THE SURFACE GRINDER. FAILURE TO ASSUME DIRECT AND FULL CONTROL CAN RESULT IN PROPERTY DAMAGE AND/OR PERSONAL INJURY.

9) The SG24/E Series electrically powered Surface Grinder is stopped by moving the ON/OFF switch located on the operator handle to the OFF position. For safety considerations, it is also recommended that the extension cord be disconnected from both the Surface Grinder and electric power source whenever the Surface Grinder is not in use on the job site.

STARTING THE SG24/G SERIES GASOLINE POWERED SURFACE GRINDER ON THE JOB SITE.

1) Position the Surface Grinder on a flat and level surface of firm foundation.

2) Refer to the material supplied by the engine manufacturer for the correct starting, operation and stopping procedures.

3) The SG24/G Series Surface Grinder is equipped with a centrifugal clutch assembly. The clutch is designed to engage at approximately 2400 RPM engine speed. Normal operation of the clutch will allow the engine to operate at its designated idle speed without the multi-accessory discs rotating. If the multi-accessory discs rotate below the designated engine idle speed, do not continue to operate the Surface Grinder until the problem has been properly corrected. Consult the Customer Service Department for specific information. There is no charge for this service.



DANGER

AS SOON AS THE CENTRIFUGAL CLUTCH ASSEMBLY BECOMES ENGAGED, THE OPERATOR MUST BE IN A POSITION TO ASSUME DIRECT AND FULL CONTROL OF THE SURFACE GRINDER. FAILURE TO ASSUME DIRECT AND FULL CONTROL CAN RESULT IN PROPERTY DAMAGE AND/OR PERSONAL INJURY.



DANGER

DO NOT OPERATE A GASOLINE ENGINE IN CLOSED SPACES WITHOUT PROPER VENTILATION. GASOLINE ENGINES PRODUCE CARBON MONOXIDE FUMES. BREATHING CARBON MONOXIDE FUMES CAN RESULT IN PROPERTY DAMAGE AND/OR PERSONAL INJURY. EXCESSIVE LEVELS OF CARBON MONOXIDE CAN CAUSE DEATH.

4) Stop the engine in accordance with the instructions as described in the material supplied by the engine manufacturer.

PROCEDURES FOR THE SAFE HANDLING OF PROPANE.



DANGER

PROPANE IS AN EXPLOSIVE GAS THAT CAN RESULT IN PROPERTY DAMAGE AND/OR PERSONAL INJURY IF IMPROPERLY TRANSPORTED, HANDLED AND UTILIZED. DO NOT SMOKE OR INTRODUCE AN OPEN FLAME IN

THE VICINITY OF A PROPANE CYLINDER OR THE SURFACE GRINDER AT ANY TIME. CONSULT APPLICABLE DEPARTMENT OF TRANSPORTATION AND OSHA REGULATIONS PERTAINING TO THE USE OF PROPANE AND PROPANE CONVERTED EQUIPMENT.

1) PERFORM ALL SERVICE WORK ON THE SURFACE GRINDER IN AN OPEN OR WELL VENTILATED AREA. NEVER ALLOW PROPANE GAS TO ESCAPE IN A CLOSED AREA. PROPANE IS HEAVIER THAN STANDARD AIR AND MAY SETTLE IN LOW AREAS.

2) NEVER PERFORM ANY CUTTING, WELDING OR REPAIR PROCESS THAT INTRODUCES AN OPEN FLAME AND/OR SPARKS IN THE VICINITY OF THE PROPANE CONVERSION SYSTEM.

3) HANDLE THE PROPANE CYLINDER CAREFULLY. DO NOT DRAG OR DROP THE CYLINDER. SUCH ACTION CAN RESULT IN PROPERTY DAMAGE AND/OR PERSONAL INJURY.

4) INSTALLATION, MAINTENANCE AND REPAIR WORK SHOULD BE ACCOMPLISHED BY QUALIFIED SERVICE PERSONNEL.

5) NEVER TEST FOR SYSTEM LEAKS WITH AN OPEN FLAME. ALWAYS USE SOAP SUDS OR AN APPROVED LEAK DETECTOR.

6) DO NOT FILL A CYLINDER THAT IS NOT PROPERLY LABELED FOR USE WITH PROPANE.

7) DO NOT FILL A CYLINDER THAT DOES NOT HAVE A CURRENT AND/OR VALID HYDROTEST DATE PROPERLY STAMPED ON ITS SURFACE.

EXAMPLE OF A PROPANE EMERGENCY PLAN.

Operators of the SG24/GHP Surface Grinder are advised to design and implement a Propane emergency plan in the event that the Propane cylinder, hoses, connections or engine conversion components develop leaks which allow the Propane to escape into the atmosphere. Propane is an extremely flammable gas that can cause property damage and personal injury.



DANGER

THE FOLLOWING INFORMATION IS INTENDED TO PROVIDE A BASIS FOR A PLAN AND IS NOT INTENDED TO BE ALL INCLUSIVE. THE KEY WORDS WILL BE ARRANGED TO SPELL OUT THE WORD PROPANE.

- 1) **PROPANE EMERGENCY.** Instruct all personnel to shout out the warning PROPANE EMERGENCY, followed by the location. Example: Propane emergency, warehouse 2.
- 2) **REPEAT THE CALL.** Upon hearing the warning, each personnel should repeat the warning.
- 3) **OFF WITH ALL UTILITIES.** Personnel nearest the utilities should pull all main switches and close all related valves.
- 4) **PHONE THE FIRE DEPARTMENT.** Give the location, specific details of the emergency and directions to the location site. Do not hang up until the fire department has the complete information it requires. Carbon dioxide and dry chemical fire extinguishers may be used. **NEVER UTILIZE CARBON TETRACHLORIDE FIRE EXTINGUISHERS.**
- 5) **ALL TOOLS OFF.** Immediately turn off all air, hydraulic and electrically powered tools and machines.
- 6) **NO VEHICLES MOVE.** No vehicles, even if electrically powered are allowed to operate. Shut down all vehicle accessories, including two-way radios.
- 7) **EVACUATE NOW.** Have all personnel walk to the nearest exit away from the direction of the emergency area.

STARTING THE SG24/GHP PROPANE CONVERTED SURFACE GRINDER ON THE JOB SITE.

- 1) Position the Surface Grinder on a flat and level surface of firm foundation.
- 2) Inspect the Propane cylinder, all hoses, fittings and conversion components for visible damage and the potential for leaks. Leaks can be detected by applying a soap and water mixture to connections with a non metallic (spark proof) brush.



DANGER

USE OF A METALLIC AND/OR IMPROPER TYPE BRUSH CAN PRODUCE SPARKS. SUCH OCCURRENCE CAN BE THE IGNITION SOURCE OF AN EXPLOSION, RESULTING IN PROPERTY DAMAGE AND/OR PERSONAL INJURY.

- 3) Determine that the Propane cylinder is properly fastened and secured in the mounting cradle.



DANGER

AN IMPROPERLY SECURED PROPANE CYLINDER CAN BE THE CAUSE OF DAMAGED/LEAKING FITTINGS, HOSE AND OTHER COMPONENTS, RESULTING IN PROPERTY DAMAGE AND/OR PERSONAL INJURY.

- 4) Open the Propane cylinder valve.
- 5) Move the engine throttle control lever to the 1/4 open position.
- 6) Propane converted, gasoline engines do not require the addition of choke for the starting procedure. An engine choke control mechanism is not provided on the converted engine.
- 7) Depress both the regulator and filter buttons for one second, FIGURE 35.
- 8) Start the engine by pulling on the recoil starter handle. The engine will normally start within 1 or 2 pulls. If the engine fails to start, repeat Steps 7 and 8 until starting is accomplished.
- 9) The SG24/GHP Propane converted Surface Grinder is equipped with a centrifugal clutch assembly. The clutch is designed to engage at approximately 2400 RPM engine speed. Normal operation of the clutch will allow the engine to operate at its designated idle speed without the multi-accessory discs rotating. If the multi-accessory discs will not stop rotating at the lowest engine idle speed, do not continue to operate the Surface Grinder. Contact the Customer Service Department for specific information. There is no charge for this service.

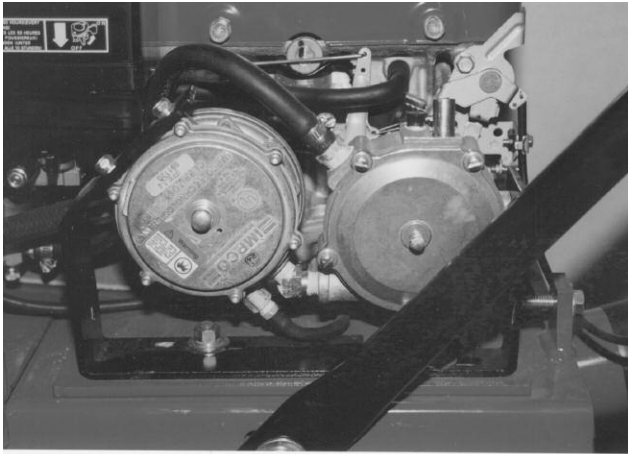

FIGURE 35



DANGER

AS SOON AS THE CENTRIFUGAL CLUTCH ASSEMBLY BECOMES ENGAGED, THE OPERATOR MUST BE IN A POSITION TO ASSUME DIRECT AND FULL CONTROL OF THE SURFACE GRINDER. FAILURE TO PROPERLY ASSUME DIRECT AND FULL CONTROL CAN RESULT IN PROPERTY DAMAGE AND/OR PERSONAL INJURY.



DANGER

DO NOT OPERATE A GASOLINE ENGINE IN CLOSED SPACES WITHOUT PROPER VENTILATION. GASOLINE ENGINES PRODUCE CARBON MONOXIDE FUMES. BREATHING CARBON MONOXIDE FUMES CAN RESULT IN PROPERTY DAMAGE AND/OR PERSONAL INJURY. EXCESSIVE LEVELS OF CARBON MONOXIDE CAN CAUSE DEATH.

10) The SG24/GHP Surface Grinder is stopped by moving the engine throttle control lever to the STOP position.

11) Close the Propane cylinder valve.

12) Inspect the Propane cylinder, all hoses, fittings and conversion components for visible damage during use and the potential for leaks. Replace any questionable component with a factory approved replacement only.



CAUTION

If the Surface Grinder and/or an individual component/accessory does not appear to be functioning properly, STOP and do not further operate the Surface Grinder until the proper corrective action has been completed. If there are any questions regarding the proper operation of the Surface Grinder, contact the Customer Service Department BEFORE further utilization. There is no charge for this service.

COUNTERACTING THE PROPANE REFRIGERATION EFFECT.

The combination of a high Propane flow rate and relatively small cylinder size (20 lbs.) can produce a sudden and drastic reduction in heat output and/or engine stoppage even though a substantial quantity of Propane remains in the cylinder.

Propane in the cylinder is in a liquid state. It must be vaporized before it can be utilized in the internal combustion process. But vaporization requires the absorption of heat energy and the source of this energy has an important bearing upon the operation of the Surface Grinder.

Since the Propane is enclosed inside the cylinder, the pressure rises. It rises until it reaches a limit for that temperature. This local pressure, referred to as the vapor pressure, is what delivers the Propane vapor to the engine. Vapor pressure is a variable entity. It decreases as ambient temperature decreases and increases as ambient temperature increases. If the temperature of the Propane becomes too low, insufficient pressure will be available to operate the Surface Grinder. This can especially happen if the Surface Grinder is operated in very cold climates.

The problem is that Propane actually cools itself. There are two factors that can affect Propane temperature. The first factor is ambient, or the surrounding air temperature. The second factor has to do with the absorption of heat energy when liquid Propane vaporizes. As the Propane inside the cylinder begins to vaporize it actually robs or reduces the temperature of the Propane that remains. Each pound of Propane requires 185 BTU just to change states from a liquid to a vapor. The effect is to cool the remaining Propane.

The cooling process is known as the refrigeration effect. If it continues long enough and proceeds fast enough, the Propane temperature and pressure will fall so low that continued operation of the Surface Grinder can be impossible, even with a full cylinder. Frost often forms on the outside of the cylinder as a warning that excessive refrigeration is occurring.

Fortunately, the refrigeration effect can be counterbalanced by a flow of heat energy into the cylinder from warmer, ambient air. This occurrence is referred to as convection heating. It can replace much of the heat energy lost in the course of vaporizing the Propane, thus effectively slowing the cooling process. In many cases, convection heating works well enough to effectively counterbalance the refrigeration effect, but there are still a number of external factors that can reduce efficient convection.

The first factor is that the surface area of liquid Propane inside the cylinder decreases with usage. A decreasing amount of liquid surface area available for convection heating produces an increase in the refrigeration effect and increased Propane cooling. Let's take the example of a filled cylinder. At first, the Propane temperature drops rapidly as the vaporizing Propane robs the heat energy of the remaining liquid supply. However, the colder Propane causes heat to flow into the cylinder from the warmer, ambient air. The process remains almost steady state until the heat transfer area (dictated by the amount of liquid Propane inside the cylinder) is substantially reduced. At that time, the heat inflow is reduced and accelerates the cooling process of the Propane until the vaporization rate can no longer be maintained.

Another factor that aggravates the refrigeration effect is increasing the flow rate. Operating the engine at a higher speed requires a higher fuel flow rate. Propane cooling is in directly proportional to the vaporization rate. Many times this rate can not be counteracted by convection heating. The process drastically reduces the amount of fuel made available to the engine.

Frost accumulation on the cylinder can also impede the efficiency of heating convection. Use of the Surface Grinder in high humidity areas can also create the formation of frost on the cylinder. The high water vapor content of humid air comes in direct contact with the colder exterior surface of the cylinder and locally freezes. Frost creates an insulation blanket surrounding the cylinder that effectively prevents heat energy transfer or convection heating necessary to counterbalance the refrigeration effect.

While frost is an enemy, wind actually is an ally. Direct exposure to forced convection in the form of wind flowing over the cylinder creates a boundary layer. The boundary layer substantially increases the amount of convection heating.

There are several other tips that can be demonstrated to reduce refrigeration effect.

- a) Keep the cylinder filled, especially in cold weather. Never allow the Propane level to fall below 1/3 of its rated capacity.
- b) Whenever possible, always store cylinders in a warm storage area.
- c) The Propane conversion kit includes a vaporizer to assist proper flow rates during operation in cold, ambient temperatures.
- d) Watch for and avoid the formation of frost on the cylinder. Keep the cylinder fully exposed to the surrounding ambient air. Do not cover or protect the cylinder so as to become obstructed.
- e) Whenever possible, keep the cylinder exposed into the prevailing wind. This will significantly increase the heat transfer rate and overall utilization time from the cylinder.

OPERATING THE SURFACE GRINDER ON THE JOB SITE.

Application: All Models



DANGER

THE GRINDING PROCESS PRODUCES EXCESSIVE NOISE, VIBRATION AND FLYING DEBRIS. ALL OPERATORS AND WORK PERSONNEL IN THE VICINITY OF THE SURFACE GRINDER MUST WEAR APPROPRIATE SAFETY EYE WEAR AND HEARING PROTECTION DEVICES. OTHER SAFETY APPAREL AND/OR PROCEDURES, DEEMED NECESSARY BY SUPERVISORY PERSONNEL MUST ALSO BE WORN AND/OR PRACTICED BY ALL APPROPRIATE PERSONNEL.



DANGER

EXERCISE EXTREME CAUTION WHEN OPERATING THE SURFACE GRINDER IN THE VICINITY OF DECK INSERTS, PIPES, COLUMNS, OPENINGS, LARGE CRACKS, UTILITY OUTLETS OR ANY OBJECT PROTRUDING FROM THE SURFACE. CONTACT WITH SUCH OBJECTS CAN LEAD TO LOSS OF MACHINE CONTROL, RESULTING IN PROPERTY DAMAGE AND/OR PERSONAL INJURY.

DANGER

DO NOT OPERATE A GASOLINE ENGINE IN CLOSED SPACES WITHOUT PROPER VENTILATION. GASOLINE ENGINES PRODUCE CARBON MONOXIDE FUMES. BREATHING CARBON MONOXIDE FUMES CAN RESULT IN PROPERTY DAMAGE AND/OR PERSONAL INJURY. EXCESSIVE LEVELS OF CARBON MONOXIDE CAN CAUSE DEATH

1) The Surface Grinder incorporates counterrotating discs for mounting a wide variety of multi-accessory attachments. The counterrotating action results in a "self propelled" effect that substantially enhances machine control and reduces fatigue as long as the multi-accessory attachment does not come in direct contact with a protruding obstruction from the floor. Direct contact with such an obstruction can result in rapid and jerky directional movement of the machine. In most operating situations, direct contact with a protruding obstruction from the floor will result in the multi-accessory attachment becoming dislodged from the counterrotating disc. This occurrence is intended to protect the Surface Grinder from excessive damage and allow the operator to remain in proper control of the machine.

DANGER

ALWAYS MAINTAIN PROPER CONTROL OF THE SURFACE GRINDER. IF AN OPERATOR LOOSES CONTROL OF THE MACHINE, A "RUNAWAY" SURFACE GRINDER CAN RESULT IN PROPERTY DAMAGE AND/OR PERSONAL INJURY. BECAUSE OF THE UNIQUE OPERATING CHARACTERISTICS OF THE SURFACE GRINDER, THERE IS NO PROVISION FOR THE ELECTRIC MOTOR/ENGINE TO AUTOMATICALLY STOP IF THE OPERATOR FAILS TO MAINTAIN PROPER CONTROL.

DANGER

WHEN OPERATING THE SURFACE GRINDER ON ABOVE GROUND FLOOR LEVELS, EXERCISE EXTREME CAUTION TO PREVENT LOSS OF CONTROL THAT COULD ALLOW THE MACHINE AND/OR OPERATOR TO FALL DOWN TO LOWER LEVELS. SUCH AN OCCURRENCE CAN RESULT IN PROPERTY DAMAGE AND/OR PERSONAL INJURY.

2) Productivity rates with the various multi-accessory attachments can be increased with the addition of external weight being applied to the area over the counterrotating discs, FIGURE 36. Maximum allowable external weight is 300 lbs. Exceeding this figure can result in permanent structural damage to the Surface Grinder. Provisions for securing the weight by the means of strapping or other, appropriate methods is provided.



FIGURE 36

DANGER

DO NOT OPERATE THE SURFACE GRINDER WITHOUT ALL EXTERNAL WEIGHT PROPERLY SECURED TO THE MAIN FRAME. A SUDDEN CHANGE IN MOVEMENT OR DIRECTION CAN ALLOW THE UNSECURED WEIGHT TO FALL OFF THE SURFACE GRINDER, RESULTING IN LOSS OF MACHINE CONTROL, PROPERTY DAMAGE AND/OR PERSONAL INJURY. THIS PROCEDURE IS ESPECIALLY IMPORTANT WHEN OPERATING THE SURFACE GRINDER ON FLOORS AND/OR

SURFACES ABOVE GROUND LEVEL.

 **DANGER**

DO NOT OPERATE THE SG24/GHP PROPANE CONVERTED SURFACE GRINDER WITH WEIGHT APPLIED DIRECTLY UPON THE PROPANE CYLINDER. PROPERTY DAMAGE AND/OR PERSONAL INJURY CAN RESULT. IF EXTERNAL WEIGHT IS REQUIRED, POSITION IT AROUND THE CYLINDER AREA AND PROPERLY SECURE AS ABOVE, FIGURE 37.

3) Proper operator posture and stance will enhance operational safety and overall productivity, FIGURE 38. For most job applications, operate the engine at maximum, governed speed. Consult the material supplied by the engine manufacturer and the **Specifications** section for specific information.



FIGURE 37

4) The wide variety of potential work surface materials along with the corresponding variety of job site environments, makes it impossible to develop a standardized operating procedure for the Surface Grinder. Use of the Surface Grinder will require constant trial and error testing until satisfactory results are achieved. Experience gained over time and common sense will help minimize the amount of necessary testing. Many factors will directly affect the operating parameters and/or techniques utilized for a specialized job application. Some of these factors include:

a) Work surface material yield and tensile values. As a general rule, these values will determine material removal rate per unit of time. Materials with high yield and tensile values will characteristically resist/limit

material penetration. For such materials, the accepted procedure is to make a number of multiple passes over the work surface rather than attempt to make a single, deep pass. The net effect is to actually increase productivity: more material removed in less time. Other added benefits to this technique are decreased vibration, less operator fatigue and increased component service life.



FIGURE 38

b) Higher material removal rates can sometimes be achieved by making a series of shallow passes 90 degrees to each other to form a waffle like pattern. This technique is especially useful when removing deeper accumulations of rubber, paint, dirt debris, etc. from industrial floors.

5) The grinding process on many work surface materials can produce sparks, dust and other foreign particle contamination.

 **DANGER**

SPARKS PRODUCED BY THE ACTIONS OF MULTI-ACCESSORY OPTIONS AGAINST THE WORK SURFACE (FOR EXAMPLE: STRIKING ANCHOR BOLTS) MAY COME IN CONTACT WITH MATERIALS THAT CAN RESULT IN A FIRE AND/OR EXPLOSION. THIS OCCURRENCE CAN RESULT IN PROPERTY DAMAGE AND/OR PERSONAL INJURY.

 **DANGER**

THE CREATION OF DUST AND OTHER FOREIGN

PARTICLE CONTAMINATION FROM THE OPERATIONAL PROCESS CAN RESULT IN PROPERTY DAMAGE AND/OR PERSONAL INJURY. FOR SUCH OPERATING CONDITIONS, ALWAYS WEAR A NIOSH/MSHA APPROVED DUST/MIST RESPIRATOR. CONSULT APPLICABLE OSHA REGULATIONS FOR SPECIFIC INFORMATION.

6) Dust and other particle contamination can be controlled by the following methods:

a) The Surface Grinder is equipped with a 1-1/2, 2 or 3 inch outside diameter vacuum tube adaptor located at the rear of the machine. An industrial type vacuum system and front shield assembly can be attached to the Surface Grinder to remove/control dust and other particle contamination from the work surface. A hose clamp is sometimes required to properly secure the vacuum hose to the vacuum tube, FIGURE 39.

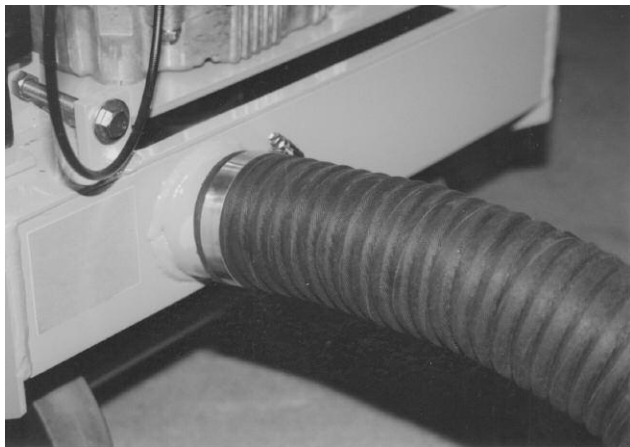

FIGURE 39

DANGER

ALWAYS UTILIZE A VACUUM SYSTEM DESIGNED TO OPERATE WITHIN THE SPECIFIC JOB SITE REQUIREMENT. DUST MATERIAL CAN MEET CLASS II OR CLASS III SPECIFICATIONS OF THE NATIONAL ELECTRIC CODE® FOR HAZARDOUS LOCATION CLASSIFICATIONS. CONSIDERATION MUST ALSO BE GIVEN TO THE CREATION OF HAZARDOUS TYPE MATERIALS REQUIRING SPECIFIC DISPOSAL PROCEDURES. DETERMINE THAT THE VACUUM SYSTEM IS PROPERLY DESIGNED TO OPERATE WITHIN THESE ATMOSPHERES. CONSULT CURRENT NATIONAL ELECTRIC CODE®, OSHA AND ENVIRONMENTAL

PROTECTION AGENCY REGULATIONS FOR SPECIFIC INFORMATION.

b) Water/sand slurry mixture applied directly to the work surface can be an effective method of reducing the effects of grinding and other material removal processes. This method can be a productive alternative when removing adhesives containing asbestos. A negative effect of this method is that the water/sand slurry mixture can be classified as a hazardous material, requiring proper disposal procedures.

7) Normal usage of the Surface Grinder will allow the build-up and accumulation of work surface materials on interior surfaces. It is highly recommended that both the interior and exterior surfaces be properly cleaned after the completion of each usage.

CAUTION

Failure to properly clean the interior surfaces of the Surface Grinder can result in dried material build-up and accumulation directly affecting bearing service life.

DANGER

EXERCISE EXTREME CAUTION WHEN UTILIZING ANY SOLVENT TO REMOVE ACCUMULATED MATERIALS FROM THE SURFACES OF THE MACHINE AND RELATED COMPONENTS. MANY SOLVENTS ARE FLAMMABLE. DO NOT SMOKE OR INTRODUCE FLAME IN THE WORK AREA. PROVIDE ADEQUATE VENTILATION AND WEAR PROPER SAFETY APPAREL.

DANGER

PROPERLY DISPOSE OF ALL ACCUMULATED MATERIALS PER OSHA AND ENVIRONMENTAL PROTECTION AGENCY CODES AND REGULATIONS. MANY ACCUMULATED MATERIALS CAN BE CLASSIFIED AS HAZARDOUS AND REQUIRE PROPER DISPOSAL PROCEDURES. CONTACT THE APPLICABLE GOVERNMENT AND/OR PRIVATE AGENCIES FOR SPECIFIC INFORMATION.

8) On job applications where the work process creates a considerable amount of loose material, it can become almost impossible to determine proper material removal depths and the extent of work already accomplished. The problem can be compounded if a vacuum system is not utilized. Loose material should be removed by sweeping or other, appropriate processes and the Surface Grinder utilized until conditions again warrant removing the accumulated material.

STOPPING THE SG24/E SERIES ELECTRICALLY POWERED SURFACE GRINDER.

Stopping the Surface Grinder is accomplished by moving the ON/OFF switch located on the operator handle to the OFF position. For safety considerations, it is also recommended that the extension cord be disconnected from both the Surface Grinder and electric power source whenever the Surface Grinder is not in use on the job site.

STOPPING THE SG24/G SERIES GASOLINE POWERED SURFACE GRINDER.

1) Stopping the Surface Grinder is accomplished by moving the engine throttle lever to the idle speed position (depicted by the turtle). Machines powered by Honda engines can then be stopped by further moving the engine throttle lever until the ignition system is grounded.

2) Machines powered by other engines may utilize a separate ON/OFF ignition switch. If so equipped, turn the switch to the OFF position. Consult the material supplied by the engine manufacturer for specific information.

STOPPING THE SG24/GHP PROPANE CONVERTED SURFACE GRINDER

1) Stopping the Surface Grinder is accomplished by moving the engine throttle control lever to the idle speed position (depicted by the turtle). Machines powered by Honda engines can be then stopped by further moving the engine throttle control lever until the ignition system is grounded. Consult the material supplied by the engine manufacturer for specific information

2) Turn the Propane cylinder valve to the completely closed position.

3) Inspect the Propane cylinder, all hoses, fittings and conversion components for visible damage during use

and the potential for leaks. Replace any questionable component with a factory approved replacement only.

OPERATIONAL PARAMETERS AND TECHNIQUES FOR THE SG24 SERIES SURFACE GRINDER.

Application: All Models

Early Age Grinding

Early age grinding is an alternative to floating and troweling. It gets its name from the fact that the concrete is ground at an early age, after it has set but before it has gained much structural strength. The process usually involves the following steps:

- 1) Normal screeding of the floor.
- 2) Smoothing the floor surface with a skip float.
- 3) Cover the floor with polyethane sheeting.
- 4) Removing the sheeting and grinding the floor down a uniform depth of approximately 1/32 inch within 24 to 48 hours of the initial pouring.

The C06 and C10 silicon carbide grinding stones are usually used for the process, although the multi segmented, dry diamond blades can be used as an alternative with substantially greater productivity rates. The main benefit of early age grinding is that it eliminates late work in cold weather. With ordinary finishing methods, a slab cast in the morning of a cold weather day might not get finished troweled until very late at night. With grinding, the construction crew is able to leave the job at the end of a normal work day and return 1 or 2 days later to finish the job. Early age grinding may not reduce the total number of work hours, but it usually eliminates the need for work at overtime rates, which can substantially increase total project costs.

One side benefit of early age grinding is that the process demands less skill than conventional floating and troweling. This makes it an attractive process where skilled crew personnel may not be available. It is also an excellent procedure for concrete floors that will be eventually covered by carpet or an applied coating.

Definitions of Floor Flatness and Levelness

The terms flatness and levelness have poorly understood meanings in everyday speech, but have important distinctions in floor construction.

Flatness is defined as planarity or lack of curvature. A more simple definition is that a flat floor is smooth and free of bumps and dips. An unflat floor is bumpy and wavy. Levelness is defined as horizontality or lack of slope. A level floor is horizontal. A floor that is unlevel is sloped or tilted.

A floor can be flat, but still not level. Some floors are specifically designed to be unlevel; they can be intentionally sloped for drainage considerations. Very few, if any, floors are specifically designed to be unflat. Unfortunately, many turn out that way. Flatness and levelness are both desirable, but have different implications for the floor user. Flatness is critical where the user's main concern is the behavior of wheeled type vehicles. Levelness is critical where the user's main concern is with fixed structures such as shelving, racks and the placement of machine tools.

Exceptions exist, but for most users, flatness is more important than levelness. The reasoning is that fixed equipment can be shimmed or adjusted to compensate. However, it is not as easy to adapt a wheeled vehicle to a floor that is not flat enough to allow for proper action.

Flatness and levelness also have different implications for the floor contractor. Flatness is determined mainly by finishing methods. Levelness is determined mainly by the side forms.

Defined Versus Random Traffic Patterns

Floors are subject to two kinds of traffic patterns: defined and random. On a defined traffic floor, vehicle movement is confined to fixed paths. On a random traffic floor, vehicles are free to roam, though inevitably, some traffic patterns are used more than others.

The distinction is important because the two kinds of traffic demand different methods of measuring surface regularity. On a defined traffic floor, a continuous (or nearly continuous) profile in each of the paths can be measured. But where traffic is random, the possible travel paths are infinite in number. What usually results is statistical sampling; selected points or lines are checked and assumed that they represent the whole floor surface.

The highest degree of surface regularity is found among the defined traffic floors. Defined traffic floors allow the designer and contractor to focus on a limited number of critical areas. When a defined traffic floor is out of tolerance, it is relatively easy to identify the defects for correction---usually by employing a grinding

process.

How to Define Surface Regularity

Since the middle 1980s, new methods of defining surface regularity have been adopted as national standards. Older methods will continue to be utilized, although they are less effective. The following methods will be discussed:

- 1) The F number system for random traffic floors
- 2) The TR34 system for defined traffic floors

Both methods are not of equal value. For random traffic floors, F numbers provide the most complete and consistent system. For defined traffic floors, the TR34 system is superior.

The F number system utilizes a pair of numbers to define surface regularity. The flatness number, F_f , is based upon the curvature over a horizontal distance of 24 inches. The levelness number, F_l , is based upon the floor slope over a horizontal distance of 10 feet. The standard test for F numbers is specified in ASTM E1155 and/or most recent version.

With both F_f and F_l , higher numbers mean greater surface regularity. Though the scale ranges from zero to infinity, almost all floors have F numbers between 10 and 100 for both flatness and levelness. Since the scale is linear, an F_f50 floor is exactly twice as flat as an F_f25 floor.

Most F number specifications are written in a two tier format. The overall F numbers apply to the floor taken as a whole. The local F numbers apply to each individual slab and are usually only one half to two thirds the overall values.

The overall F numbers are not just simple averages. ASTM E1155 covers how to combine F numbers.

The two tier format encourages contractors to achieve good surface regularity while allowing for minor defects. The attempt is to pour the entire floor to the specified overall F numbers. If, for instance, the construction crew has a bad day and fails to meet the specified overall numbers for the slab, the slab can still be accepted provided it meets the specified local numbers. Such an occurrence serves as a warning to the crew that it must strive for a better performance on later slabs, so as to bring the overall F numbers up to the specified values. If a slab fails to meet even the specified local numbers, it must be repaired or

replaced, but such failures seldom occur if all parties understand what is expected from the start.

Designers are not obligated to use this two tier format. Some designers specify a single F number pair (F_f and F_l) which applies to each individual slab. But this also raises the risk that slabs will be rejected.

FIGURE 40 depicts the overall and minimum F numbers for various floor classes. The floor classification is from the American Concrete Institute. Although the F number system is only a few years old, it offers these advantages:

- a) The system controls both flatness and levelness.
- b) There is a standard test method.
- c) The system recognizes the statistical nature of profile testing on random traffic floors.
- d) The system is infinitely variable.

**F_f/F_l Classifications
set forth by ASTM E1155**

FLOOR PROFILE QUALITY CLASSIFICATION	MINIMUM F _f /F _l NUMBER REQUIRED			
	SPECIFIED F NUMBERS		MINIMUM LOCAL F NUMBERS	
	FLATNESS F _f	LEVEL F _l	FLATNESS F _f	LEVEL F _l
CONVENTIONAL	15	13	13	10
BULL-FLOAT	20	15	15	10
STRAIGHTEDGE				
FLAT	30	20	15	10
VERY FLAT	50	30	25	15

FIGURE 40

One of the major limitations of the F number system is that it does not control the surface regularity at joints. Because joints are statistical anomalies, the standard test method forbids measurements within 24 inches. The designer specifying by F number has two methods to accommodate the problem. The first solution is to locate joints at locations where surface regularity is not important. The second solution is to design specifications for the joints themselves.

The TR 34 Tolerances for Defined Traffic Floors

The TR 34 System divides defined traffic floors into three categories:

- a) Superflat

- b) Category 1

- c) Category 2

For each category, the TR 34 System specifies limits for three properties:

Property 1 is the difference in elevation between two points 12 inches apart, measured in the direction of vehicle traffic. This is the levelness tolerance.

Property 2 is the difference in slope over 24 inches measured in the direction of vehicle traffic. This is the flatness tolerance. It is identical as the 24 inch curvature utilized in the F number system.

Property 3 is the difference in elevation between opposite points in the left and right wheel path, measured perpendicular to the direction of vehicle traffic. As with Property 1, it is a levelness tolerance. The TR 34 System specifies different values for Property 3 depending upon whether the distance between left and right wheel paths is more or less than 5 nominal feet.

The Superflat category is intended for very narrow aisle warehouses where the highest standards are required. Category 1 is suggested for very narrow aisle warehouses where the vertical lift height is between 26 and 43 feet. Category 2 is for very narrow aisle warehouses where the vertical lift height is under 26 feet and the use of low rise, automatically controlled vehicles. No matter which category of surface regularity is specified, it is accomplished by measuring elevations on 12 inch centers. This is very similar to an F number survey, but with an important distinction. In an F number survey, the elevation profiles are made on the floor at random. With the TR 34 System, the survey measurements are made on the actual paths of the vehicles that will utilize the floor.

Improving the Wear Resistance of Concrete Floors by Grinding with the SG24 Series Surface Grinder

Poor wear resistance can often be traced back to a surface that is weaker than underlying levels of the pour. This occurrence can result from bad finishing techniques, improper curing or early freezing.

Where surface weakness is a problem, grinding can be a solution. The process is similar to the early age technique. The grinding depth is typically 1/16 to 1/8 inch. A large project should not be attempted until a small test area has proven that the technique will produce the desired results. Usually only a square yard

of floor is ground with the normal wear tests performed.

Repair costs can be minimized by grinding only those floor areas that accommodate traffic. For example, in a pallet rack warehouse, it may be necessary to grind only the aisle areas and not under any of the racks. The grinding process can adversely affect the surface regularity. Where specific properties are important, it may be necessary to survey the floor during the grinding process to ensure that flatness and levelness specifications are maintained.

Cleaning Concrete Floors to Improve the Wear Resistance with the SG24 Series Surface Grinder

Clean concrete floors have a longer service life than dirty, poorly maintained floors. Loose debris produces three-bodied wear by allowing particles to roll between the traffic and the floor surface. With some types of debris, especially when lodged in vehicle wheels, wear can be immediate and severe.

The SG24 Series Surface Grinder can be utilized with a number of multi accessories to clean and extend concrete floor service life. The SCRAPE-R-TACH® floor coatings removal system readily removes food, oil and rubber accumulations from high traffic floor areas. The Clean Sweep™ silicon impregnated, rotary brushes along with a biodegradable detergent applied to floors removes ground in dirt and debris from shop and industrial floors. Dry diamond segmented discs and blocks can be utilized to remove surface imperfections.

Service

PREVENTATIVE MAINTENANCE CHECK LIST.

Application: All Models

The normal operation of the Surface Grinder produces extreme dirt and dust, along with levels of random vibration. Before operating the Surface Grinder, the following service list should be accomplished. This list is for reference only and is not intended to be all inclusive. Other subject areas can be added at the discretion of the owner(s) and/or operator(s):

- 1) Check all fasteners for proper torque values. If a fastener requires retorquing, consult a torque chart for proper value. Properly discard and replace any worn fastener with a factory approved, replacement part only.
- 2) Check the V-belts for wear. Adjust or replace as necessary. Check pulleys for wear and proper alignment. Many loose materials created as a result of operating processes can be extremely abrasive.
- 3) Keep the Surface Grinder clean. Wash the unit after each use. Keep loose materials from accumulating around engine cooling fins. Determine that the interior sections of the frame are free of material build-ups. Such build-ups can restrict the operating process and present a potential safety hazard. Clean and remove any material build-up from the Surface Grinder after each use.
- 4) Engine service life can be extended with proper air cleaner maintenance. Consult the material supplied by the engine manufacturer for specific information.
- 5) Check for proper oil level. Always use clean, high quality engine oil. Change oil as required. Consult the material supplied by the engine manufacturer for specific information.
- 6) Remove material accumulations from the exterior surfaces of the electric motor. The electric motor is a totally enclosed, fan cooled (TEFC) design. Keep the fan fins clear of material accumulations to enhance air flow over the motor exterior for cooling purposes.



DANGER

DO NOT PERFORM PREVENTATIVE MAINTENANCE CHECKS WITH THE ENGINE OR ELECTRIC MOTOR RUNNING. STOP THE POWER SOURCE AND DISCONNECT THE SPARK PLUG OR EXTENSION CORD BEFORE PERFORMING ANY MAINTENANCE TO THE SURFACE GRINDER. IF

GASOLINE ENGINE POWERED, RECONNECT THE SPARK PLUG BEFORE RESTARTING THE ENGINE. IF ELECTRIC MOTOR EQUIPPED, TURN THE ON/OFF SWITCH TO THE OFF POSITION BEFORE RECONNECTING THE EXTENSION CORD. IMPROPER PROCEDURES CAN RESULT IN PROPERTY DAMAGE AND/OR PERSONAL INJURY.

CHECKING V-BELT TENSION AND ALIGNMENT.

Application: All Models

Proper V-belt tension and alignment are essential for smooth transmission of horsepower and extended service life. Improper tension and alignment will accelerate V-belt wear and contribute to decreased productivity. The V-belt is tensioned at the factory with the maximum recommended tension force. Check the belt tension at least two times during the first day of operation as there will normally be a rapid decrease in belt tension until it has been run in. Check the belt tension every eight hours of operation thereafter and maintain tension within the recommended range. The correct operating tension for a V-belt drive is the lowest tension at which it will not slip under peak load conditions.

Tools Required:

1 each, 16 inch minimum length straightedge
1 each, 10 lbs minimum capacity, tension scale or belt tension tool

1) If the Surface Grinder is powered by an engine, disconnect the spark plug wire. If powered by an electric motor, disconnect the extension cord or Surface Grinder from the power source.

2) Position the Surface Grinder on a suitable work bench with the V-belts approximately at waist level.

3) Remove the rubber latches and slide the belt guard away from the engine/electric motor until it clears the catch mechanism. If the Surface Grinder is equipped with a Propane converted engine, determine that the Propane cylinder valve is closed before uncoupling the hose. Remove the belt guard from the main frame. Clean the inside of the belt guard with an appropriate solvent. Check for signs of wear and damage.



CAUTION

Observe all applicable safety precautions for the solvent.

4) Check the belt tension using the spring scale or belt tension tool midway between the engine clutch pulley and the transmission pulley. Belt tension should measure approximately 0.22 inch at 3-1/4 to 4-3/8 lbs. measured force range, FIGURE 41. If tension is within specifications, proceed to Step 5. If tension is not within specifications, refer to **INSTALLING A REPLACEMENT V-BELT** for specific information.

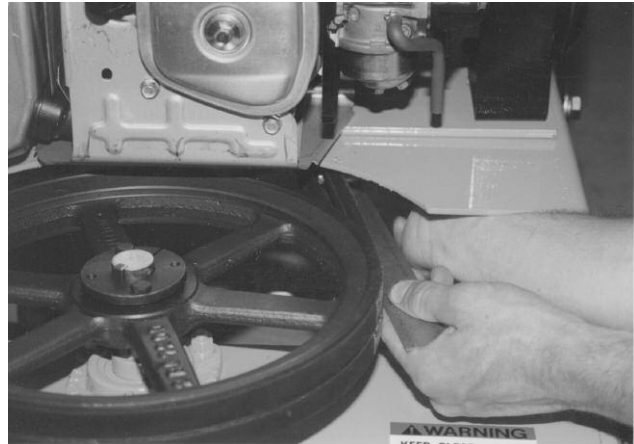

FIGURE 41

5) Belt alignment is checked with the straightedge. Place the straightedge squarely against the transmission pulley. Properly aligned pulleys should also place the straightedge squarely against the engine/motor pulley. Remove the straightedge and rotate the engine pulley 120 degrees, FIGURE 42. Recheck alignment with the straightedge. Repeat the process until the engine/motor pulley is rotated a full 360 degrees. Maximum allowable misalignment is + - 1/32 inch. If pulley alignment is not within specifications, refer to **INSTALLING A REPLACEMENT V-BELT** for specific information.

6) Install the belt guard to the main frame. Determine that all safety related decals affixed to the belt guard are fully readable. If any decal is not fully readable, replace with a factory approved, replacement part only. If the Surface Grinder is equipped with a Propane converted engine, properly install the Propane cylinder and recouple the hose.

7) If the Surface Grinder is powered by an engine, reconnect the engine spark plug wire. If powered by an electric motor and the machine is to be used immediately, reconnect the extension cord or Surface

Grinder to the power source. Determine that the ON/OFF switch located on the operator handle is in the OFF position.



DANGER

UNEXPECTED MACHINE START UP CAN RESULT IN PROPERTY DAMAGE AND/OR PERSONAL INJURY.

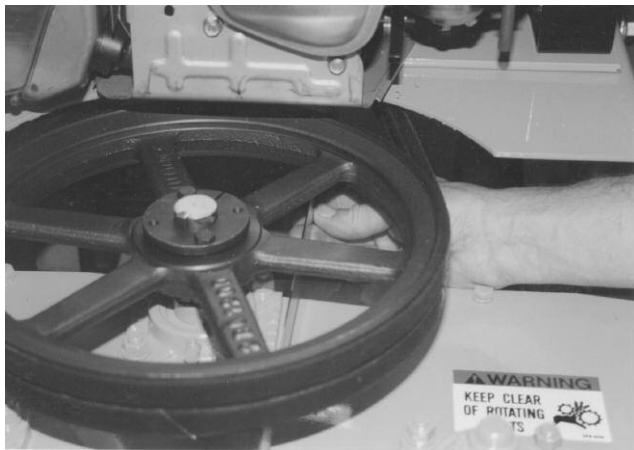

FIGURE 42

INSTALLING A REPLACEMENT V-BELT, CENTRIFUGAL CLUTCH OR PULLEY.

Application: As Specified

Tools Required:

- 1 each, 7/16 wrench
- 2 each, 1/2 wrenches
- 1 each, 9/16 wrench
- 1 each, 5/32 Allen wrench
- 1 each, 16 inch minimum length straightedge
- 1 each, 10 lbs minimum capacity, tension scale or belt tension tool
- 1 each, torque wrench, 35 ft lbs (47 Nm.) capacity with 7/16 inch and 9/16 inch sockets
- 1 each, belt tension tool

Parts Required:

- 2 each, PN B50 V-belt (if required)
- 1 each, PN SG24-0520 Pulley Assembly (if required)
- 1 each, Pulley Assembly (if required):
 - PN SG24-0510 (50Hz only)
 - PN SG24-0500 (60Hz only)
- 1 each, PN SG24-0320 Centrifugal Clutch Assembly (if

SG24 GRINDER FORM GOM3259601, VERSION 1.2, AUTHORIZATION: DVR, PAGE: 43

required)

1) Position the Surface Grinder on a suitable work surface with the V-belts approximately at waist level.

2) If the Surface Grinder is equipped with a Propane converted engine, determine that the Propane cylinder valve is closed before uncoupling the hose. Remove the rubber latches and slide the belt guard away from the engine/electric motor until it clears the catch mechanism. Remove the belt guard from the main frame. Clean the inside of the belt guard with an appropriate solvent. Check for signs of wear and damage. Secure in a proper storage area.



CAUTION

Observe all applicable safety precautions for the solvent.

3) Using the 1/2 inch wrenches, loosen the engine/motor mounting plate cap screws.

4) With the same wrenches, rotate the engine take-up cap screws counterclockwise to loosen the V-belts and allow the engine/electric motor to slide toward the front of the main frame, FIGURE 43.



FIGURE 43

5) Remove the worn V-belts. Inspect the engine/electric motor and transmission pulleys for wear and damage. Install the replacement belts, PN B50 in pairs. The Surface Grinder utilizes two V-belts. Always install replacement belts in matched pairs. Never replace just one of the V-belts.



CAUTION

Do not operate the Surface Grinder with only one V-belt installed. One V-belt is not capable of transmitting proper horsepower and torque levels to the multi-accessory discs.

a) Do not install replacement belts if the pulleys have excessively worn grooves. Such pulleys should be replaced to insure proper belt fit. Operating the V-belts in worn pulley grooves will accelerate wear, reduce horsepower and torque levels and significantly reduce component service life.

b) A V-belt should never be forced over a pulley. More belts are broken from this cause than from actual failure in service.

c) Keep the belts as clean and free of foreign material as possible. Do not use belt dressing.

6) The centrifugal clutch assembly utilized on both the gasoline engine powered and Propane converted Surface Grinders is designed to deliver an extended service while requiring minimal service. However, long term use of the Surface Grinder can allow the accumulation of fine dusts and powders within the clutch assembly. These dusts and powders can dramatically reduce the capacity of the the clutch drum bearing, resulting in the following operational characteristics:

a) When operating the engine at idle speed, the centrifugal clutch assembly will not fully disengage, allowing the multi accessory discs to rotate at low speed.

b) When the engine is advanced to and/or from the idle speed position, erratic machine movement or "grinding" and "thrashing" noises from the clutch area are detected.

In many cases, clutch assembly removal, a cleaning of the bearing surfaces, and reassembly will solve the problem.

7) Rotate the take-up cap screws clockwise until the V-belts have enough tension to not allow them to fall off the centrifugal clutch and/or pulleys.

8) Using the 9/16 inch wrench, remove the retaining cap screw from the engine crankshaft. Using the 5/32 inch Allen wrench, loosen the two set screws located

near the snap ring. The clutch can now be removed from the engine crankshaft. FIGURE 44.

9) The centrifugal clutch is comprised of a rotor/shoe assembly, a drum/pulley assembly, a thrust washer and retaining snap ring.

a) Using the snap ring pliers, remove the snap ring from the clutch assembly, FIGURE 45.

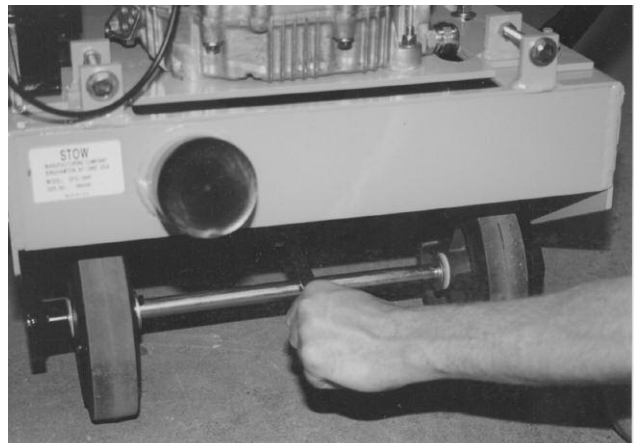

FIGURE 44



DANGER

WEAR SAFETY EYEWEAR AND OTHER APPROPRIATE APPAREL WHEN DISASSEMBLING THE CENTRIFUGAL CLUTCH ASSEMBLY. CAUTION ALL ONLOOKERS REGARDING THE POTENTIAL FOR FLYING DEBRIS. FAILURE TO EXERCISE PROPER SAFETY PRECAUTIONS CAN RESULT IN PROPERTY DAMAGE AND/OR PERSONAL INJURY.



FIGURE 45

b) Disassemble the rotor/shoe assembly and drum/pulley assemblies. Clean each component with an appropriate safety solvent. Pay special attention to the inside diameter bore of the drum/pulley assembly bearing. Inspect for signs of excessive wear and damage which can allow the rapid formation of foreign material accumulation, FIGURE 46.



FIGURE 46



CAUTION

Observe all applicable safety precautions for the solvent.

c) The clutch rotor springs and shoes are relatively maintenance free and should deliver many hours of trouble free operation before complete replacement is required. Severely discolored springs and shoes are

signs of excessive clutch slippage caused by improper operation techniques, FIGURE 47.



FIGURE 47

10) Reassemble the components in reverse order and install the clutch assembly on the engine crankshaft with the pulley facing toward the engine.

11) Reinstall the V-belts to the transmission and clutch pulleys and tighten as outlined in CHECKING V-BELT TENSION AND ALIGNMENT.

REPLACING THE LORD® TYPE ELASTOMERIC MOUNTS ON THE MULTI-ACCESSORY DISCS.

Application: All Models

Lord® type elastomeric rubber mounts are utilized to allow each multi-accessory disc to maintain full contact with the work surface. The rubber mounts afford a constant flex rate for each multi-accessory disc throughout its service life. The rubber compound is resistive to the effects of ultraviolet radiation and most common chemicals encountered when operating the Surface Grinder .

During the manufacturing process, the rubber mounts are pressed into specially machined cavities in the disc mounting plates. Under normal usage and job applications, the Lord® type rubber mounts will deliver appropriate performance for the expected service life of the Surface Grinder. However, an attachment mounted in the multi-accessory disc that directly strikes a vertical floor obstruction with sufficient impact force can cause one or more of the mounts to become separated from the mounting plate. This occurrence will not allow the multi-accessory disc to maintain full contact with the work surface. This occurrence is also

intended to protect the transmission gears and bearings from costly damage and the operator from an impact force that could cause personal injury.

Tools Required:

- 1 each, 5/16 Allen wrench
- 2 each, 5/8 wrenches
- 1 each, arbor press of sufficient capacity and stability

Parts Required:

- PN J-6250-2 Elastomeric Mount (as required)
- 1 container each: PN 80 Installation Lubricant (or approved equivalent)

1) If the Surface Grinder is powered by an engine, disconnect the spark plug wire. If powered by an electric motor, disconnect the extension cord or Surface Grinder from the power source.

2) Position the Surface Grinder on a suitable work bench with the multi-accessory discs at waist level.

3) If the Surface Grinder is equipped with a Propane converted engine, determine that the Propane cylinder valve is closed before uncoupling the hose. Remove the rubber latches and slide the belt guard away from the engine/electric motor until it clears the catch mechanism. Remove the belt guard from the main frame. Clean the inside of the belt guard with an appropriate safety solvent. Check for signs of wear and damage. Secure in a proper storage area.

 **CAUTION**

Observe all applicable safety precautions for the solvent.

4) Tilt the Surface Grinder back until the operator handle comes in contact with the surface. The surface Grinder may not be in a stable position in this configuration. To minimize the possibility of property damage and/or personal injury, apply an appropriate weight to the handle to stabilize the Surface Grinder, FIGURE 48. Other means can also be utilized to support the frame and provide proper machine stability. Appropriate wheel chocks are recommended. Follow the instructions for this procedure as outlined in INSTALLING A MULTI-ACCESSORY ATTACHMENT (not including multi-segmented, dry diamond blades) IN THE COUNTERROTATING DISCS.

5) Utilizing the Allen wrench, remove the affected aluminum multi-accessory disc (if still attached) from the Surface Grinder.

6) Utilizing the 9/16 inch wrenches, remove the cap screws that retain the Lord® rubber mounts to both the mounting plate and transmission shaft.

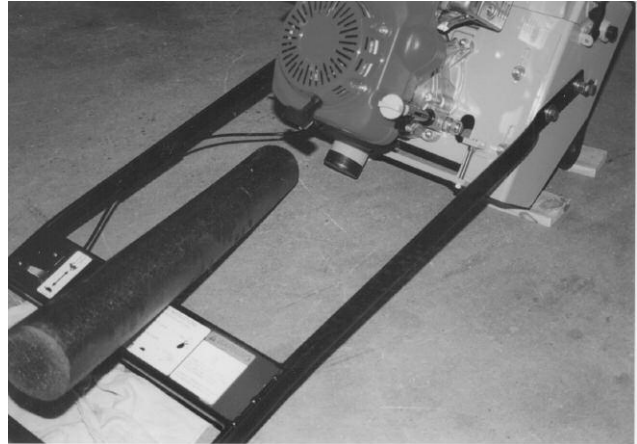

FIGURE 48

7) Inspect the appropriate cavities in the mounting plate for wear and damage. Any nick or burr must be removed by the use of an appropriate file, followed by the use of 240 grit sandpaper FIGURE 49.

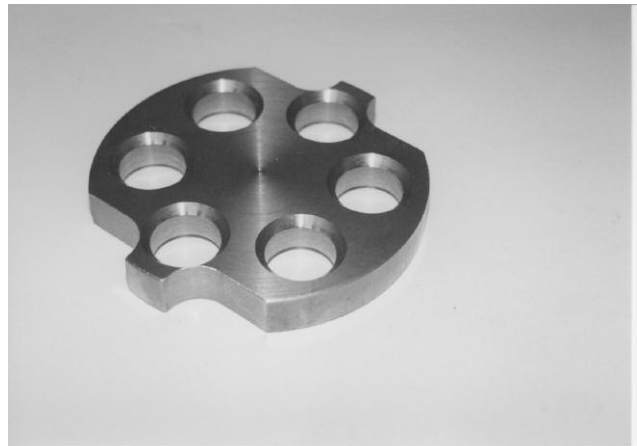

FIGURE 49

8) Apply the installation lubricant to the exterior surface of the elastomeric mount to minimize damage when pressing into the mounting disc. If the factory supplied lubricant is not available, an acceptable alternative is the use of common liquid soap.



CAUTION

Do not install an elastomeric mount without the use of an approved lubricant. Installation without an approved lubricant can produce tares in the mount, resulting in substandard operational performance and service life.

9) Support the elastomeric mount, socket and mounting plate as depicted in FIGURE 50. The mounting plate must be suspended from the arbor press to allow the mount to clear when the pressing process is completed. A short section of 1-1/2 inch inside diameter steel tubing can be utilized for this purpose. Using the arbor press, apply a steady force in a straightline direction to the mount until it fully penetrates the cavity in the mounting disc. Do not attempt to push the elastomeric mount through the mounting disc with excessive force. Damage to the elastomeric mount will result.

10) Reassemble the mounting discs to the transmission shaft.

11) Reassemble the mounting plate to the mounting disc.

12) Reassemble the aluminum multi-accessory disc to the mounting plate.

13) Check to determine that the replacement elastomeric mounts allow for proper position of the aluminum multi-accessory disc. If the elastomeric mounts are not properly positioned, they will require removal and reinstallation. The removal process can produce tares and abrasions in the mount that will require a new replacement.

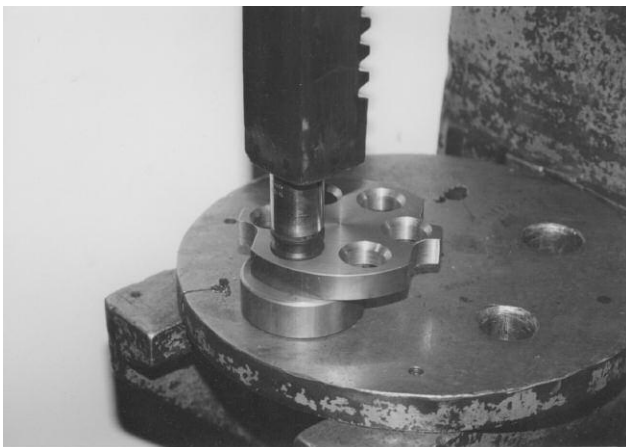

FIGURE 50

LUBRICATION REQUIREMENTS.

Application: All Models

Parts Required:

- 1 each, standard grease gun filled with one of the following: ESSO Beacon 325, Shell Alvania #2, Chevron SRI, or equivalent
- 1 each, container of dry film lubricant

1) Lubricate the caster wheel bearings with a dry film lubricant only. Dry film lubricants dry immediately upon contact. Use sparingly. Excess lubricant will attract the fine grained, powdered materials described and directly affect bearing service life.



CAUTION

Do not lubricate the caster wheels with any type of grease material. Grease will attract foreign material accumulations that can accelerate bearing wear.

2) The transmission gears are supported by extra capacity, ball bearing units. Bearings are lubricated at the time of manufacture and do not require additional servicing when placing the unit in initial service. Zerk grease fittings can promote improper service schedules and an excessive amount of over lubrication. Excess grease escaping from around the bearing insert seals will attract foreign material accumulations that can drastically shorten seal service life. Excessive amounts of grease in the bearing race cavity can actually increase friction and resulting heat increases that can also dramatically shorten bearing service life.

3) The transmission gears are lubricated at the time of assembly with approximately 24 ounces of Lubriplate GR132 grease or equivalent. This lubricant has an EP additive to better allow it to cling to the gears. The transmission should not require additional lubrication or the lubrication to be changed until service work to the gears is performed.

4) Standard bearing greasing intervals will range from once every 8 hour work day to approximately once every work week. Always maintain sufficient grease around the circumference of the bearing insert to provide its self-aligning feature and prevent the formation of corrosion.

5) Do not apply belt dressing materials to the V-belts for

the purpose of minimizing slippage. These products typically attract foreign material accumulations that can accelerate component wear. Excessive V-belt slippage can be eliminated with proper V-belt tension and alignment.

ELECTRIC MOTOR SERVICE.

Application: SG24/E Series Surface Grinder

The electric motor is capable of operating for many years with a reasonably small amount of maintenance. Before attempting to service the motor, disconnect the Surface Grinder from the power source. Clean the motor surfaces periodically, preferably with a vacuum cleaner. Heavy accumulations of dirt and lint will result in overheating and premature failure of the motor.

The electric motor is equipped with higher capacity ball bearings and under normal service and ambient temperatures, should not require relubrication for many years. If you feel that the motor requires relubrication, contact the local representative of the motor manufacturer for specific information.

The seals utilized with the motor are intended to deliver a longer service life in a concrete dust environment. When replacing the seals, utilize only components meeting the original factory specifications.

ENGINE SERVICE.

Application: SG24/G Series and SG24/GHP Surface Grinder.

Consult the material supplied by the engine manufacturer for specific service and maintenance information regarding:

- 1) muffler
- 2) spark plug
- 3) air filter system
- 4) carburetor adjustment
- 5) ignition system
- 6) short and long term storage
- 7) maximum governed speed
- 8) emission standards

Keep this information stored with the Operator's Manual for the Surface Grinder so it will always be available for use when the engine requires service or maintenance. A properly maintained engine will add considerably to the service life and overall productivity of the Surface Grinder.

Troubleshooting

ELECTRIC MOTOR.

Application: SG24/E Series Surface Grinder.

MOTOR FAILS TO START

ON/OFF switch in the OFF position. Turn the switch to the ON position.

Improper voltage selection. Determine the available voltage value from the power source. Move the voltage selection switch located on the motor to the proper selection.

Surface Grinder and/or extension cord is not plugged into the power source. Determine that all electrical connections have been properly made. The NEMA 6-20 Series cap and receptacle set is of a twist lock configuration and requires a twist motion to ensure a proper connection.

Improper extension cord size and capacity. Operate the Surface Grinder with copper stranded, 8 AWG or larger extension cords. Improper extension cord size and capacity will result in significant heat rise and corresponding voltage and amperage drop.

Thermal protection device activated. To protect the motor against heat related damage, an automatic thermal protection switch is provided near the voltage selection switch. High operating temperatures will activate the switch and shut the motor off. After the motor has cooled to an acceptable temperature level, depress the switch to restart.

MOTOR LOSES POWER

Improper extension cord size and capacity. Replace with cords meeting the required specifications.

Excessive extension cord length. Even with proper extension cord size and capacity, excessive cord length can reduce the available voltage and amperage to the motor. Measure the available voltage to the motor where the extension cord connects to the Surface Grinder with a voltmeter. Reduce the extension cord length as required to achieve the minimum voltage operating specification as required by the motor manufacturer.

Insufficient available voltage and amperage at the power source. Measure the available voltage at the

power source (usually a receptacle) with a voltmeter. If the available voltage is below the minimum operating specification as required by the motor manufacturer, utilize an alternative power source.

Improper motor cooling. See ELECTRIC MOTOR SERVICE.

Excessive load to the motor. See OPERATING THE SURFACE GRINDER ON THE JOB SITE.

ENGINE.

Application: SG24/G Series and SG24/GHP Propane Converted Surface Grinders

ENGINE FAILS TO START

Ignition switch in OFF or cut off position. Place switch in the ON position or move throttle control lever to the ignition operational position.

Incorrect carburetor/fuel ignition system adjustment. See **Service** section.

Air filter blocked. See **Service** section.

Ignition wire to spark plug loose or disconnected. Reconnect.

Application: SG24/G Series Surface Grinder

Fuel supply exhausted. Refill the fuel tank.

Application: SG24/GHP Propane Converted Surface Grinder

Propane cylinder valve closed. Open valve.

Propane cylinder empty. Refill cylinder.

Spark plug fouled. Replace spark plug.

Improper priming technique. See STARTING THE SG24/GHP PROPANE CONVERTED SURFACE GRINDER ON THE JOB SITE.

ENGINE LOSES POWER

Incorrect carburetor/fuel injection adjustment. See **Service** section.

Excessive carbon accumulation in combustion chamber. See **Service** section.

Excessive material build-up around the cooling fins. See **Service** section.

Application: SG24/G Series and SG24/GHP Propane Converted Surface Grinders

Water in fuel supply. Drain and replace fuel.

Fuel tank breather vent closed (if so equipped). Open vent.

Air filter blocked. See **Service** section.

Application: SG24/GHP Propane Converted Surface Grinder

Propane cylinder valve closed. Open valve.

OPERATIONAL PROBLEMS.

Application: All Models

UNEVEN MULTI-ACCESSORY ATTACHMENT WEAR

Incorrect installation of the attachment in the aluminum disc. See INSTALLING A MULTI-ACCESSORY ATTACHMENT ON THE COUNTERROTATING DISCS.

Worn or damaged gimbal head Lord® rubber mounts. Replace mounts.

Accumulation of foreign material on the multi-accessory attachment. Clean and/or replace the attachment components as necessary.

Flails and spacer washers are mounted too tight on the scarifier frame. Remove and/or replace flails and spacer washers. See MULTI-ACCESSORY ATTACHMENTS AND APPLICATIONS.

EXCESSIVE JUMPING ON THE WORK SURFACE

Incorrect installation of the attachment in the aluminum counterrotating disc. See INSTALLING A MULTI-ACCESSORY ATTACHMENT ON THE COUNTERROTATING DISCS.

Worn or damaged gimbal head Lord® rubber mounts. Replace mounts.

Loose gimbal head fasteners. Retorque fasteners as required.

ACCELERATED V-BELT WEAR

Misaligned and/or improperly tensioned pulleys. Readjust pulleys and V-belt. See **Service** section.

Worn pulleys. Replace pulleys as required. See INSTALLING A REPLACEMENT V-BELT OR PULLEY.

Improper V-belt. Replace with a name brand B50 series V-belt. Never replace a single belt. Always replace both V-belts at the same time in matched sets. See INSTALLING A REPLACEMENT V-BELT OR PULLEY.

ACCELERATED BEARING WEAR AND/OR FAILURE

Misaligned and/or improperly tensioned pulleys. Readjust pulleys and V-belts. See **Service** section.

Bent transmission input or output shaft. Replace affected shaft(s).

Improper lubrication. See LUBRICATION REQUIREMENTS.

UNEVEN GRINDING ACTION

Excessive material build-up on the caster wheel face surface. Remove material.

Excessive caster wheel bearing wear. Replace the caster wheel. Excessive axle wear. Replace axle.

Flails and/or spacer washers are mounted too tight on the scarifier frame. Remove and/or replace flails and spacer washers. See MULTI ACCESSORY ATTACHMENTS AND APPLICATIONS.

Mixing new and worn flails, silicon carbide stones, etc. Remove and replace with components of the same, approximate size and diameter. See MULTI ACCESSORY ATTACHMENTS AND APPLICATIONS.

Storage

Application: All Models

Proper procedure for long term storage of the Surface Grinder will protect it against the effects of corrosion and damage. If the Surface Grinder is not to be operated for a period of 30 days or more, proceed to store as follows:

1) Clean all accumulated foreign material from the Surface Grinder utilizing an appropriate safety solvent.



CAUTION

Observe all applicable safety precautions for the solvent.

2) Follow the procedure as outlined in the material supplied by the engine manufacturer describing long term storage for the engine.

3) Check all visible parts for wear, breakage or damage. Order any part required to make the necessary repair. This will avoid a needless delay when operating the Surface Grinder at next use.

4) Apply a dry film lubricant to all exposed metal components to prevent the formation of rust.

5) Store the Surface Grinder inside. If the Surface Grinder must be stored outside, protect it with a suitable covering.

Specifications

FRAME.

STRUCTURE Unitized, welded steel plate.

DRIVE REDUCTION SYSTEM B50 Series belt/pulley/spur gear transmission.

MAXIMUM GRINDING WIDTH 24 inches (610 mm).

OVERALL MACHINE WIDTH 27-1/2 inches (699 mm).

OVERALL MACHINE LENGTH 3 inches (1346 mm).

TYPICAL OPERATOR HANDLE HEIGHT 40 inches
(1066 mm).

VACUUM CLEANER CONNECTION 1 -1/2 inch
(51 mm), 2 inch (51 mm) or
3 inch (76 mm) diameter.

GENERAL.

SG24/E BASIC WEIGHT 250 lbs (114 kg).

SG24/G BASIC WEIGHT 300 lbs (136 kg).

SG24/GHP BASIC WEIGHT 350 lbs (159 kg).

SG24/E ELECTRIC MOTOR 2 hp, 3450 RPM, 16.8 amperes @ 115 VAC, 60 Hz, or 8.4 amperes @ 230 VAC, 60 Hz, switchable when the motor is not in operation. The electric motor requires a clean (no other electric products on the same circuit) 20 ampere capacity circuit to properly function on 115 VAC, 60 Hz or 10 ampere capacity circuit to properly function on 230 VAC, 60 Hz.

SG24/G ENGINE 11 hp (82 kw) nominal, industrial quality, 4 cycle engine, 3450 RPM nominal maximum governed speed.

SG24/GHP ENGINE 11 hp (82 kw) nominal, industrial quality, 4 cycle engine, 3450 RPM nominal maximum governed speed, converted for use with Propane. The BTU content of Propane reduces the effective horsepower by approximately 20 per cent.

Left Blank

Service Parts Section
SG24 Series Surface Grinder

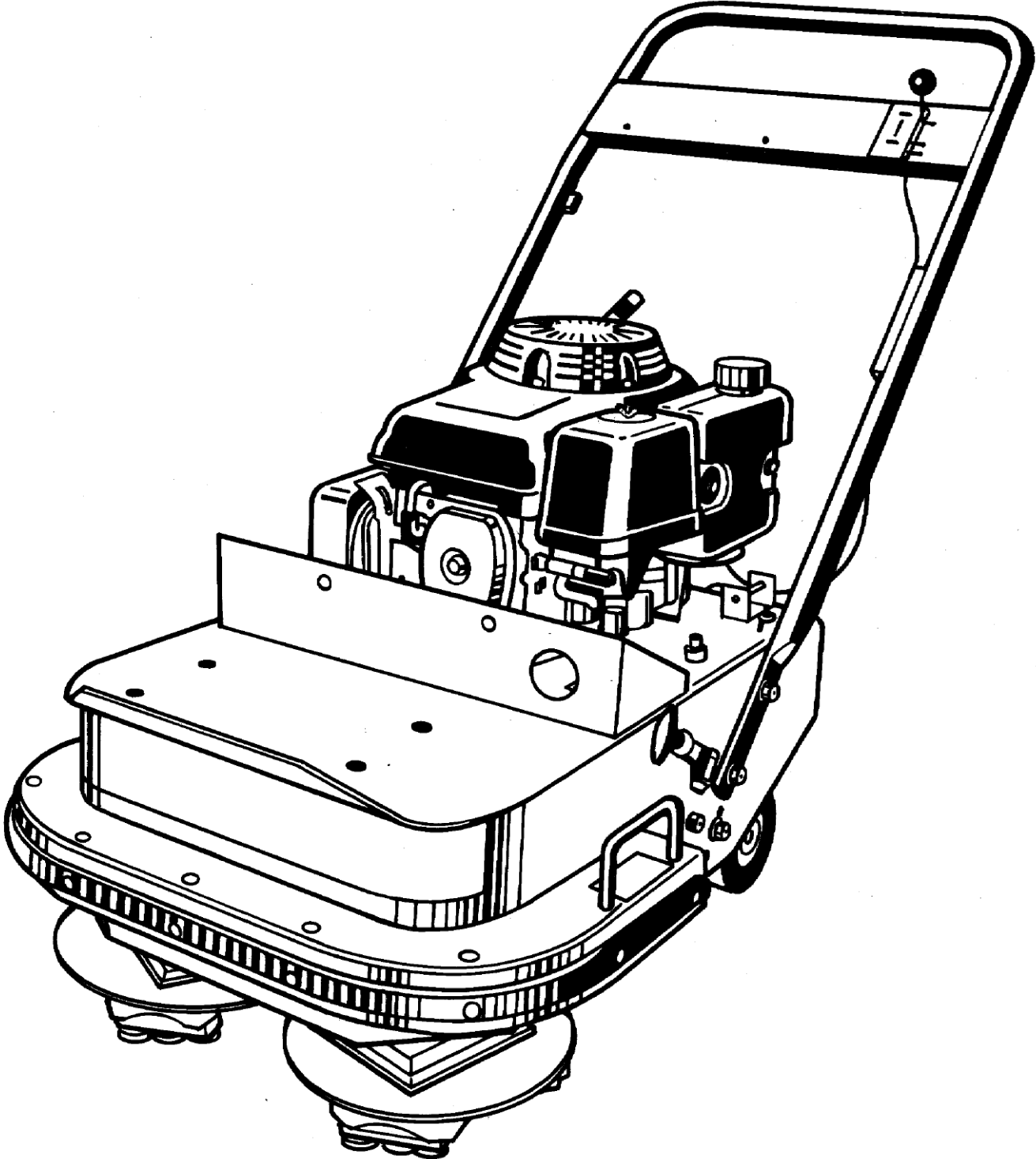

Gearbox Assembly SG24 Series Surface Grinder

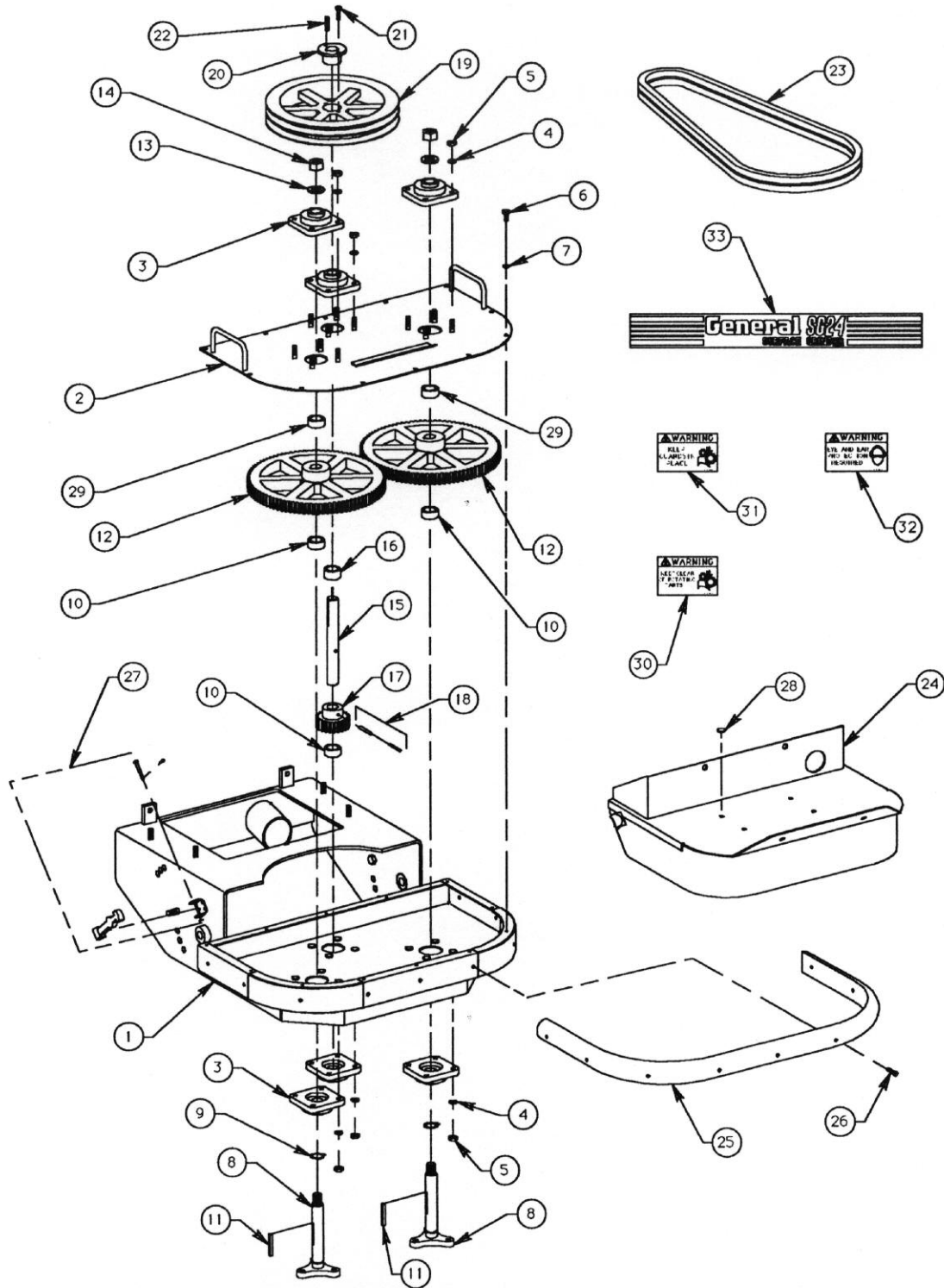

Gearbox Assembly

SG24 Series Surface Grinder

Reference Number	PART NUMBER	DESCRIPTION	QTY
1	SG24-0010	Frame, Main	1
2	SG24-0020	Cover, Transmission	1
3	FHSF205-16G	Bearing, Flange	6
4	16060000	Washer, Lock, 3/8", Plated	24
5	18060000	Nut, Hexagon, 3/8-16 UNC, Plated	24
6	15050600	Screw, Cap, 5/16-18 UNC x 3/4", Plated, Grade 5	12
7	16050000	Washer, Lock, 5/16", Plated	12
8	SG24-0030	Shaft	2
9	5160-98	Ring, Snap	2
10	SG24-0050	Spacer, Long	3
11	63041500	Key, Square, 1/4" x 1/4" x 1-7/8"	2
12	SG24-0060	Gear	2
13	17120000	Washer, Flat, 3/4", Plated	2
14	59120001	Nut, Hexagon, Jam, Nylock®, 3/4-16 UNF	2
15	SG24-0070	Shaft	1
16	SG24-0080	Spacer, Medium	1
17	SG24-0100	Gear	1
18	SG24-0280	Pin, Double Roll, 1/4" x 1-3/4"	1
19	2BK120H	Pulley	1
20	HX1	Bushing, Tapered	1
21	15040600	Screw, Cap, 1/4-20 UNC x 3/4", Plated, Grade 5	2
22	63041000	Key, Square, 1/4" x 1/4" x 1-1/4"	1
23	B50	Belt, V Type	2
24	SG24-0210	Cover, V-Belt	1
25	SG24-0220	Bumper, Rubber	1
26	27040500	Screw, Cap, Countersunk, 1/4-20 UNC x 5/8"	9
27	35R	Fastener, Cover	2
28	2633	Plug, Hole	4
29	SG24-0040	Spacer, Short	2
30	SP8-5030	Decal, Warning	2
31	SP8-5050	Decal, Warning	2
32	SP8-5040	Decal, Warning	1
33	SG24-5010	Decal, General	1

Gearbox Assembly

SG24 Series Surface Grinder

[Used Starting With Serial Number 25853]

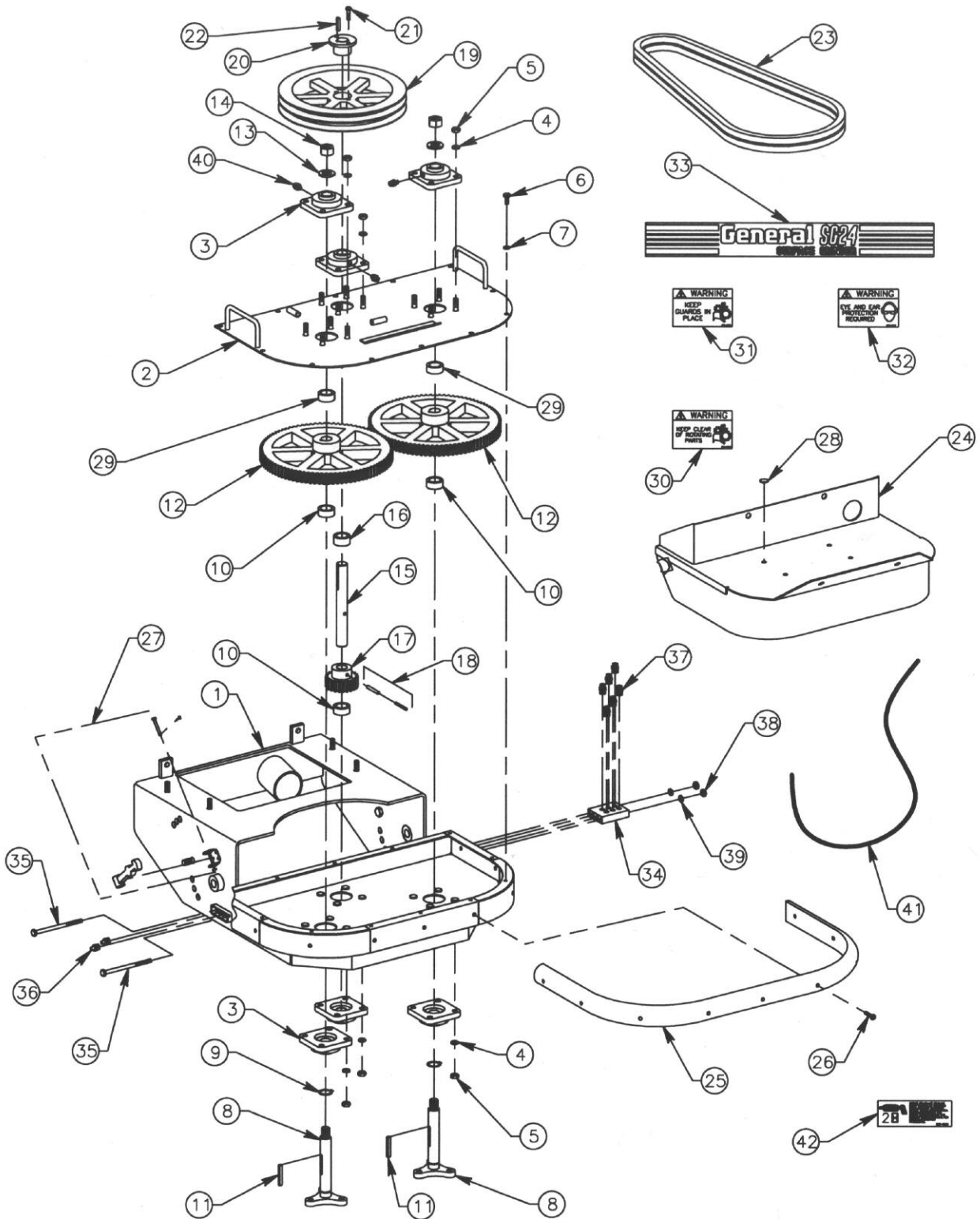

Gearbox Assembly

SG24 Series Surface Grinder

[Used Starting With Serial Number 25853]

Reference Number	PART NUMBER	DESCRIPTION	QTY
1	SG24-0010	Frame, Main	1
2	SG24-0020	Cover, Transmission	1
3	FHSF205-16G	Bearing, Flange	6
4	16060000	Washer, Lock, 3/8", Plated	24
5	18060000	Nut, Hexagon, 3/8-16 UNC, Plated	24
6	15050600	Screw, Cap, 5/16-18 UNC x 3/4", Plated, Grade 5	12
7	16050000	Washer, Lock, 5/16", Plated	12
8	SG24-0030	Shaft	2
9	5160-98	Ring, Snap	2
10	SG24-0050	Spacer, Long	3
11	63041500	Key, Square, 1/4" x 1/4" x 1-7/8"	2
12	SG24-0060	Gear	2
13	17120000	Washer, Flat, 3/4", Plated	2
14	59120001	Nut, Hexagon, Jam, Nylock®, 3/4-16 UNF	2
15	SG24-0070	Shaft	1
16	SG24-0080	Spacer, Medium	1
17	SG24-0100	Gear	1
18	SG24-0280	Pin, Double Roll	1
19	2BK120H	Pulley	1
20	HX1	Bushing, Tapered	1
21	15040600	Screw, Cap, 1/4-20 UNC x 3/4", Plated, Grade 5	2
22	63041000	Key, Square, 1/4" x 1/4" x 1-1/4"	1
23	B50	Belt, V Type	2
24	SG24-0210	Cover, V-Belt	1
25	SG24-0220	Bumper, Rubber	1
26	27040500	Screw, Cap, Countersunk, 1/4-20 UNC x 5/8"	9
27	35R	Fastener, Cover	2
28	2633	Plug, Hole	4
29	SG24-0040	Spacer, Short	2
30	SP8-5030	Decal, Warning	2
31	SP8-5050	Decal, Warning	2
32	SP8-5040	Decal, Warning	1
33	SG24-5010	Decal, General	1
34	SG24-0330	Manifold Block	1
35	15043200	Screw, Cap, 1/4-20 UNC x 4", Plated, Grade 5	2
36	SP8-0590	Grease Fitting, Straight, 1/8 NPT	2
37	SG12-0120	Connector, Grease, 1/8 NPT	6
38	18040000	Nut, Hexagon, 1/4-20 UNC, Plated	2
39	16040000	Washer, Lock, 1/4", Plated	2
40	SG12-0130	Connector, Grease	6
41	SG24-0410	Hose, Grease Line (Cut To Length Required, See Diagram Page)	REF
42	SP8-5061	Decal, Grease	1

Multi-Accessory Disc Assembly SG24 Series Surface Grinders

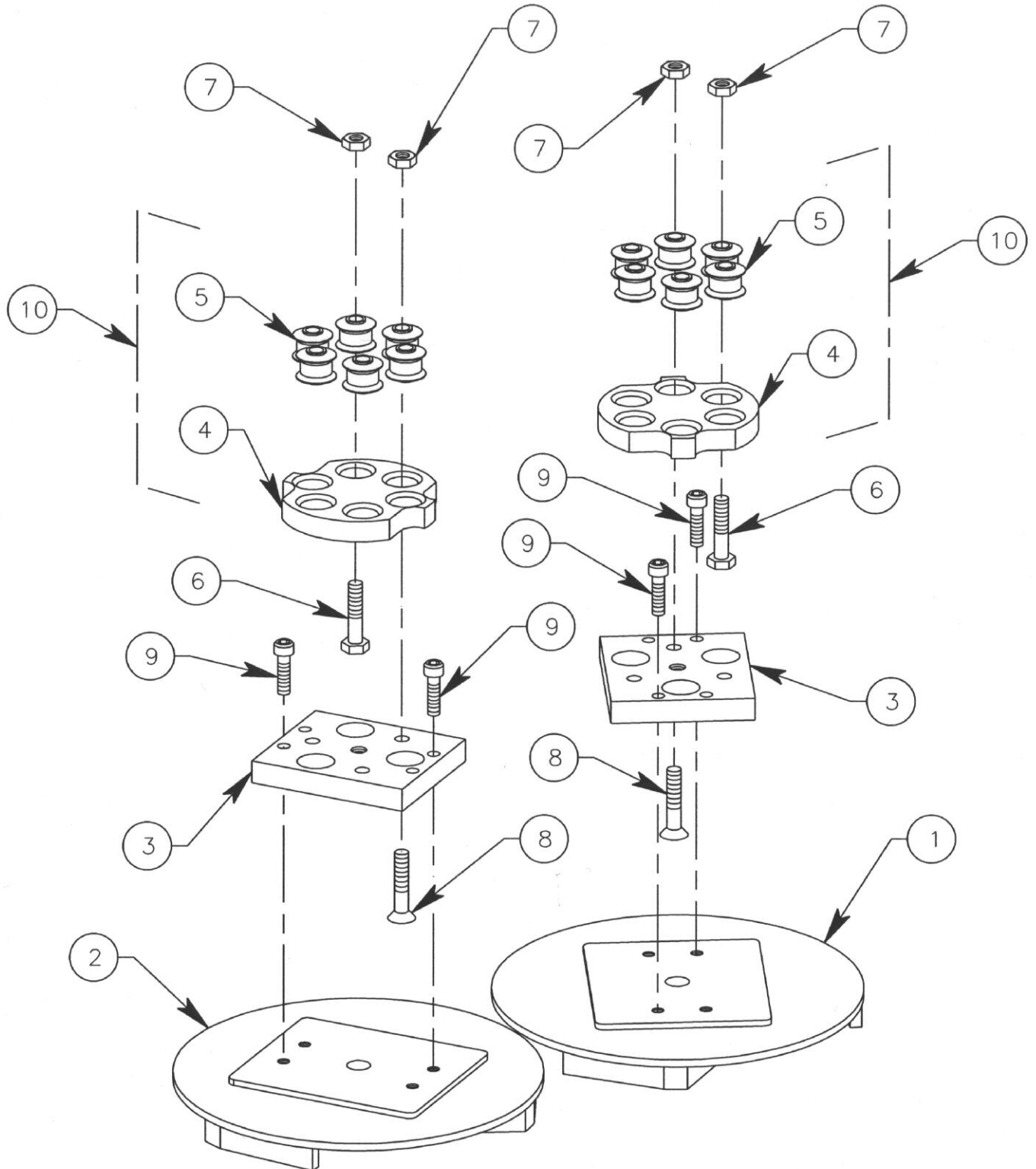

Multi-Accessory Disc Assembly SG24 Series Surface Grinders

Reference Number	PART NUMBER	DESCRIPTION	QTY
1	SG24-0140	Disc, Multi-Accessory, LH	1
2	SG24-0150	Disc, Multi-Accessory, RH	1
3	SG24-0130	Bar, Mounting	2
4	SG24-0120	Disc, Mounting	2
5	J-6250-2A	Mount, Rubber, Lord® Type	12
6	15071600	Screw, Cap, 7/16-14 UNC x 2", Plated, Grade 5	6
7	53070000	Nut, Hexagon, Locking, 7/16-14 UNC, Plated	12
8	27071800	Screw, Countersunk, 7/16-14 UNC x 2-1/4"	6
9	60061200	Screw, Socket, 3/8-16 UNC x 1-1/2", Plated	8
10	SG24-0120-A	Disc. Mounting Assembly (Included Qty 6 of J-6250-2 and Qty 1 of SG24-0120)	2

Axle Cradle Assembly SG24 Series Surface Grinder

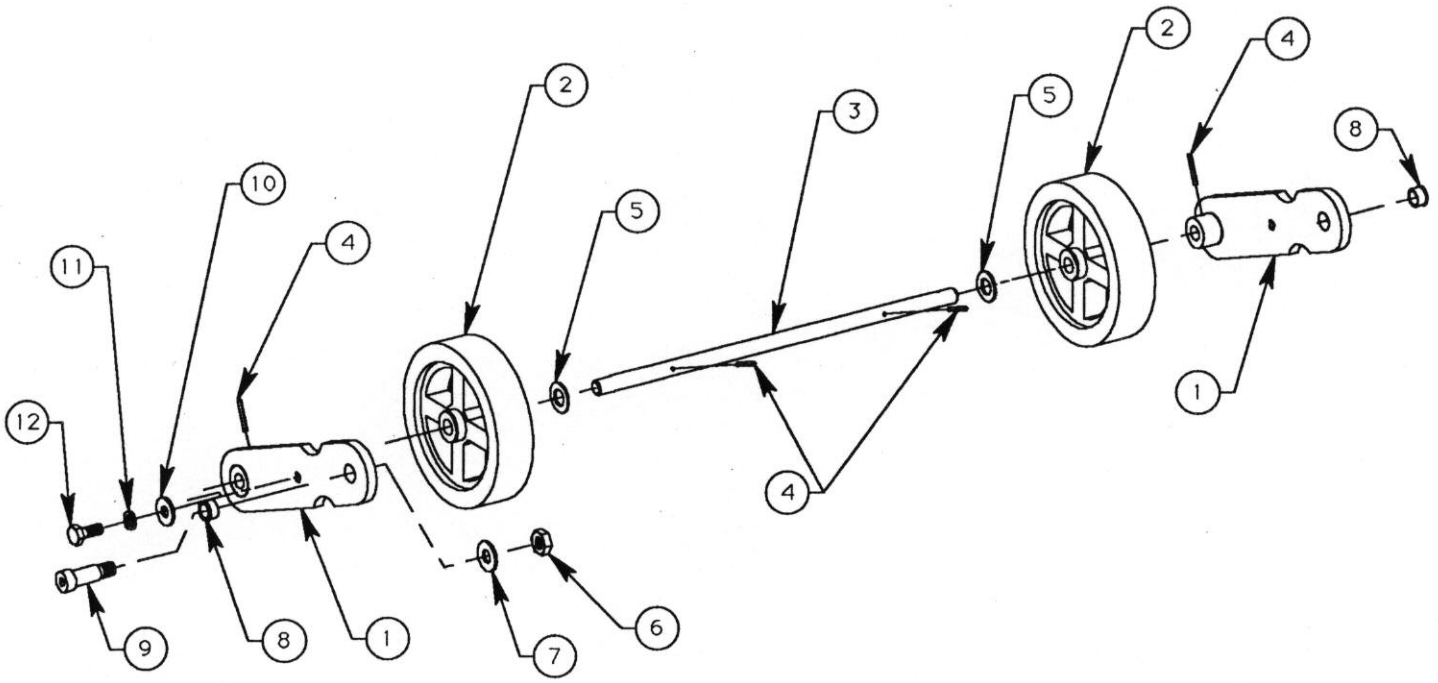

Axle Cradle Assembly SG24 Series Surface Grinder

Reference Number	PART NUMBER	DESCRIPTION	QTY
1	SG24-0190	Arm, Swing	2
2	SG24-0260	Wheel	2
3	SG24-0200	Axle, Plated	1
4	20031200	Pin, Roll, 3/16" x 1-1/2"	4
5	17120000	Washer, Flat, 3/4", Plated	2
6	18100000	Nut, Hexagon, 5/8-11 UNC, Plated	2
7	17100000	Washer, Flat, 5/8", Plated	2
8	FF-838-1	Bearing, Oilite®	2
9	62121200	Bolt, Shoulder, 3/4-10 UNC x 1-1/2"	2
10	17080000	Washer, Flat, 1/2", Plated	2
11	16080000	Washer, Lock, 1/2", Plated	2
12	15081000	Screw, Cap, 1/2-13 UNC x 1-1/4", Plated	2

Operator Handle Assembly SG24/G Series Surface Grinder [Equipped With Gasoline Engine]

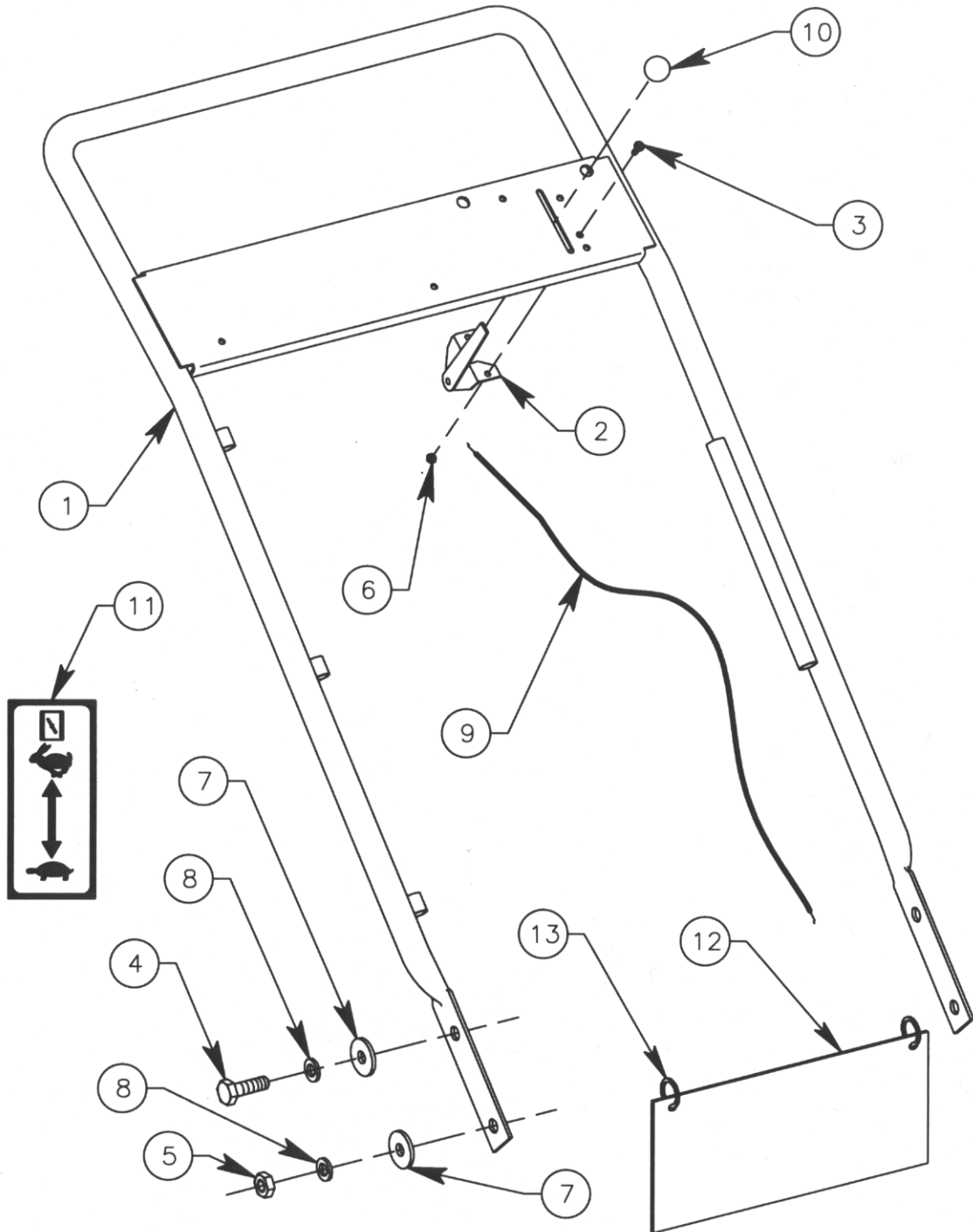

Handle Assembly

SG24/G Series Surface Grinder

[Equipped With Gasoline Engine]

Reference Number	PART NUMBER	DESCRIPTION	QTY
1	SG24-0160	Handle, Operator	1
2	SG24-0170	Lever, Throttle Control, With Cable and Knob	1
3	60030500	Screw, Socket, #10-24 UNC x 5/8", Plated	2
4	15081200	Screw, Cap, 1/2-13 UNC x 1-1/2", Plated, Grade 5	2
5	18080000	Nut, Hexagon, 1/2-13 UNC, Plated	2
6	53030000	Nut, Hexagon, Nylock®, #10-24 UNC, Plated	2
7	17080000	Washer, Flat, 1/2", Plated	4
8	16080000	Washer, Lock, 1/2", Plated	4
9	SG24-0170-020	Cable, Throttle, Complete	1
10	SG24-0170-030	Knob, Throttle, Control	1
11	SG24-5020	Decal, Throttle	1
12	SG24-5040	Sign, Quik-Tips	1
13	KIC-172	Ring, Kick-Out	2

Engine Mounting Assembly SG24/G Series Surface Grinder [Equipped With Gasoline Engine]

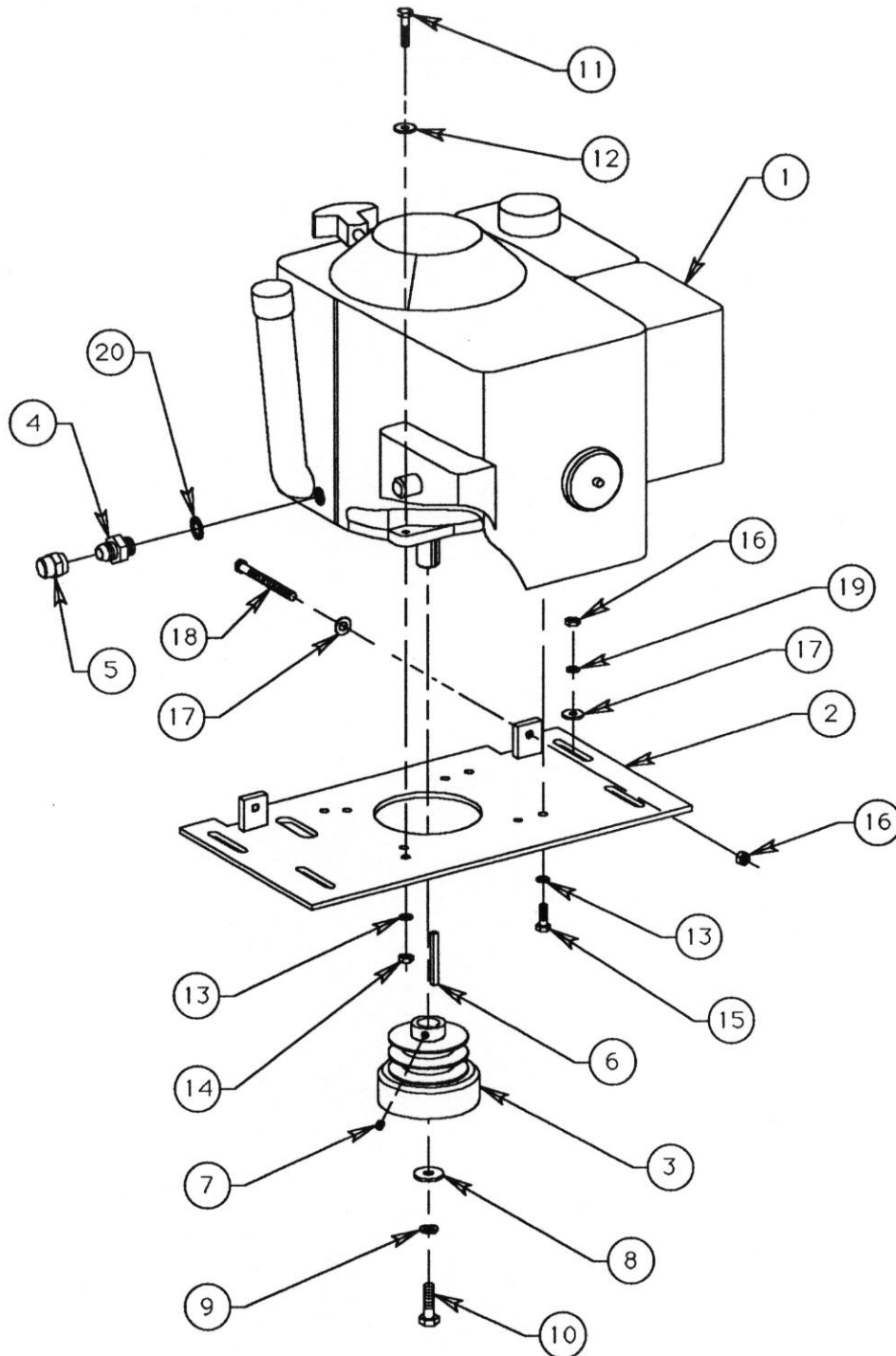

Engine Mounting Assembly SG24/G Series Surface Grinder [Equipped With Gasoline Engine]

Reference Number	PART NUMBER	DESCRIPTION	QTY
1	GXV340	Engine, Honda	1
2	SG24-0110	Mount, Gasoline Engine	1
3	SG24-0320	Clutch, Centrifugal, With Pulley, Complete	1
4	SG24-0315	Adapter, M20 x 7/8-14 UNF	1
5	SG24-0300	Cap, 37° Flare, Female, Drilled	1
6	63042000	Key, Square, 1/4" x 1/4" x 2-1/2"	1
7	31050500	Screw, Set, Cup Point, 5/16-18 UNC x 5/16"	2
8	17070000	Washer, Flat, 7/16", Plated	1
9	16070000	Washer, Lock, 7/16", Plated	1
10	15071200	Screw, Cap, 7/16-14 UNC x 1-1/2", Plated, Grade 5	1
11	15051400	Screw, Cap, 5/16-18 UNC x 1-3/4", Plated, Grade 5	2
12	17050000	Washer, Flat, 5/16", Plated	2
13	16050000	Washer, Lock, 5/16", Plated	3
14	18050000	Nut, Hexagon, 5/16-18 UNC, Plated	2
15	15050801	Screw, Cap, 5/16-24 UNF x 1", Plated, Grade 5	2
16	18060000	Nut, Hexagon, 3/8-16 UNC, Plated	6
17	17060000	Washer, Flat, 3/8", Plated	6
18	CS8-0470	Screw, Cap, 3/8-16 UNC x 3-1/2", Full Thread, Plated	2
19	16060000	Washer, Lock, 3/8", Plated	4
20	SG24-0317	Seal, Adapter	1

Operator Handle Assembly SG24/E And SG24/E3HP Series Surface Grinders [Equipped With Electric Motor]

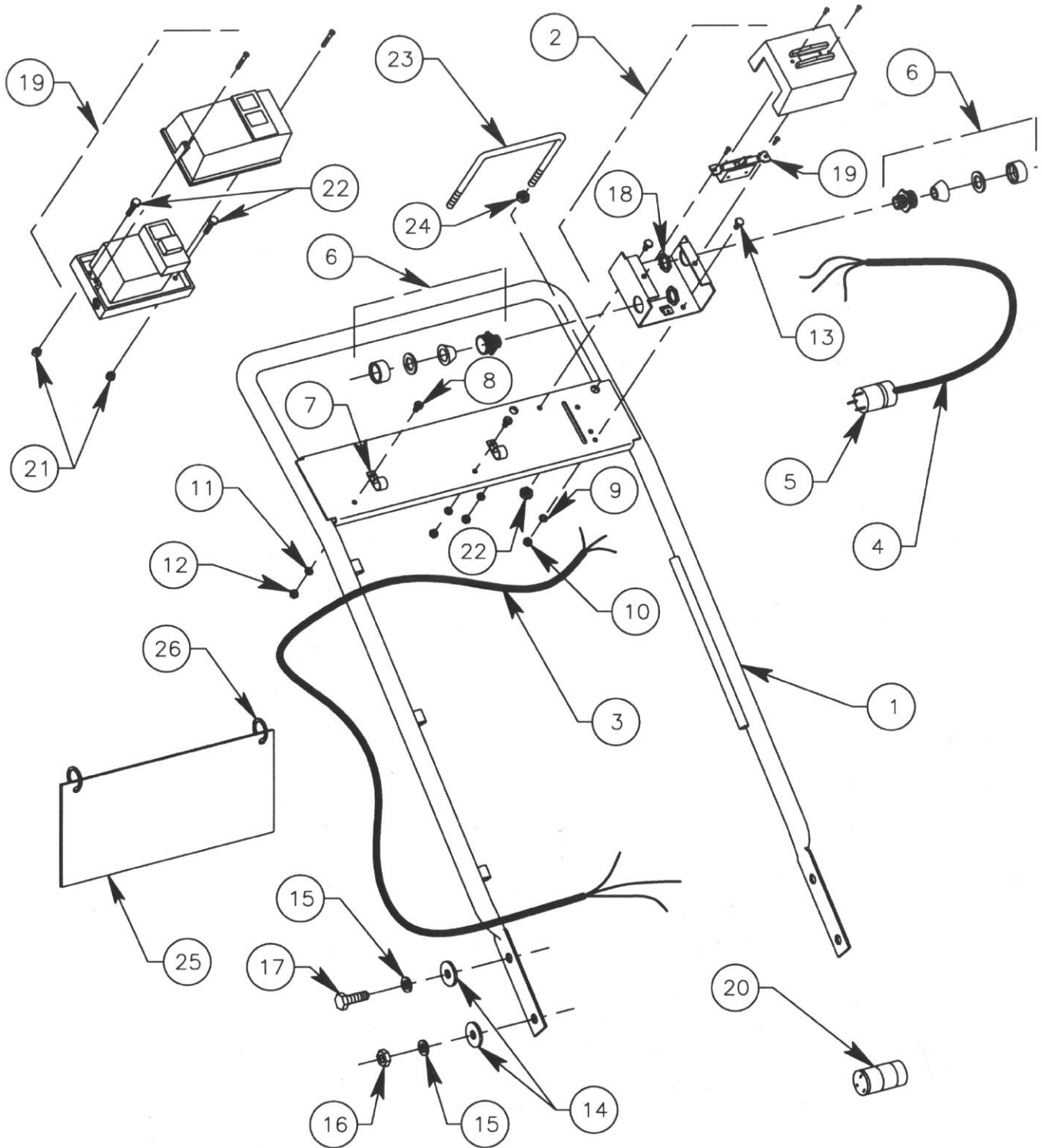

Operator Handle Assembly

SG24/E And SG24/E3HP Series Surface Grinders

[Equipped With Electric Motor]

Reference Number	PART NUMBER	DESCRIPTION	QTY
1	SG24-0160	Handle, Operator	1
2	HUB-1390	Housing, Switch (Used On SG24/E only)	1
3	SP8/E-0100	Cable	1
4	SG24-0090	Cable	1
5	HUB-2321	Plug, Male (2 hp Motor Only)	1
	SG24/E3HP-0020	Plug, Male (3 hp Motor Only)	1
6	CG-5050	Relief, Strain (Used On SG24/E only)	2
7	CWV-1007	Clamp, Cable	2
8	37030400	Screw, Pan Head, #10-32 UNF x 1/2", Plated	2
9	16040000	Washer, Lock, 1/4", Plated	2
10	18040000	Nut, Hexagon, 1/4-20 UNC, Plated	2
11	16030000	Washer, Lock, Number 10, Plated	2
12	18030000	Nut, Hexagon, 10-32 UNF, Plated	2
13	15040400	Screw, Cap, 1/4-20 UNC x 1/2", Plated, Grade 5	2
14	17080000	Washer, Flat, 1/2", Plated	4
15	16080000	Washer, Lock, 1/2", Plated	4
16	18080000	Nut, hexagon, 1/2-13 UNC, Plated	2
17	15081200	Screw, Cap, 1/2-13 UNC x 1-1/2", Plated, Grade 5	2
18	801	Nut, Bulkhead (Included With Reference Number 6) (Used On SG24/E only)	Ref.
19	HUB-1222	Switch (Used On SG24/E)	1
	SG24/E3HP-0450	(Used On SG24/E3HP50 only)	1
	SG24/E3HP-0460	(Used On SG24/EHP60 only)	1
20	HUB-2323	Receptacle, Female (Used On SG24/E only)	1
	SG24/E3HP-0010	(Used On SG24/E3HP50 and SG24/E3HP60)	1
21	53030000	Nut, Hexagon, Nylock®, #10-24 UNC, Plated (Used On SG24/E3HP50 and SG24/E3HP60)	2
22	60030500	Screw, Socket Head, #10-24 UNC, Plated (Used On SG24/E3HP50 and SG24/E3HP60)	2
23	SG24-0390	Guard, Switch	1
24	86060000	Nut, Hexagon, Flange, 3/8-16 UNC, Plated	4
25	SG24/E-5040	Sign, Quik-Tips	1
26	KIC-172	Ring, Kick-Out	2

Electric Motor Mounting Assembly SG24/E And SG24/E3HP Series Surface Grinder [Equipped With Electric Motor]

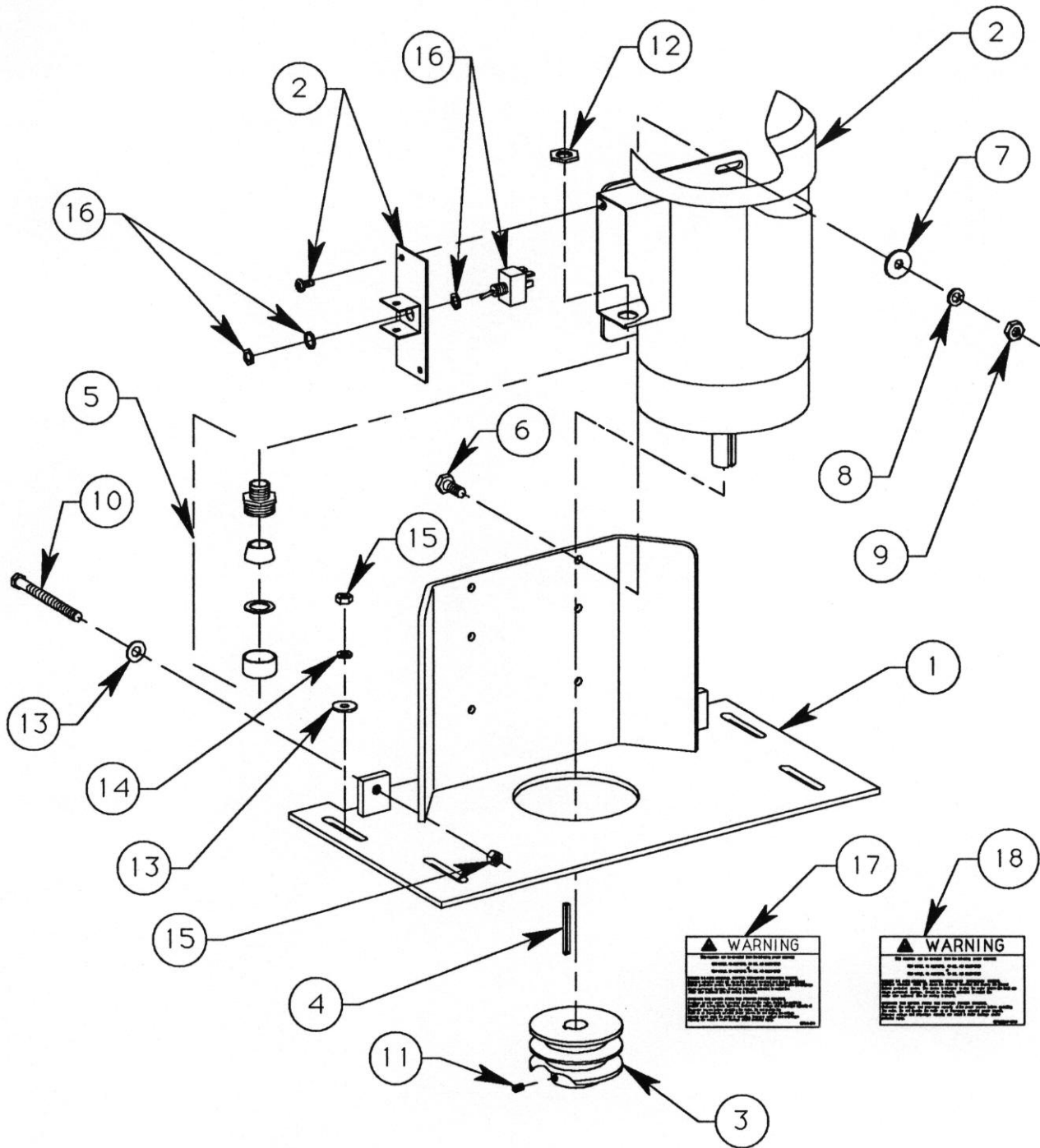

Electric Motor Mounting Assembly SG24/E And SG24/E3HP Series Surface Grinder [Equipped With Electric Motor]

Reference Number	PART NUMBER	DESCRIPTION	QTY
1	SG24-0250	Mount, Electric, Motor	1
2	121173.00	Motor, Electric, 2 HP, 115/230 VAC (Used On SG24/E Only)	1
	121360.00	Motor, Electric, 3 HP, 230 VAC, 50/60 HZ (Used On SG24/E3HP50 and SG24/E3HP60 Only)	1
3	SG24-0500	Pulley (Used On SG24/E & SG24/E3HP 60 HZ Only)	1
	SG24-0510	Pulley (Used On SG24/E3HP 50 HZ Only)	1
4	63031600	Key, Square, 3/16" x 3/16" x 2"	1
5	CG-3150	Relief, Strain	1
6	15050800	Screw, Cap, 5/16-18 UNC x 1", Plated	6
7	17050000	Washer, Flat, 5/16", Plated	6
8	16050000	Washer, Lock, 5/16", Plated	6
9	18050000	Nut, Hexagon, 5/16-18 UNC, Plated	6
10	CS8-0470	Screw, Cap, 3/8-16 UNC x 3-1/2, Full Thread, Plated	2
11	31050500	Screw, Set, Cup Point, 5/16-18 UNC x 5/16"	1
12	801	Nut, Bulkhead (Included With Reference Number 6)	Ref.
13	17060000	Washer, Flat, 3/8", Plated	6
14	16060000	Washer, Lock, 3/8", Plated	4
15	18060000	Nut, Hexagon, 3/8-16 UNC, Plated	6
16	002922	Switch, Toggle, 115/230 VAC Selection (Used On SG24/E Only)	1
17	SP8-5070	Decal, Warning (Used On SG24/E Only)	1
18	SP8/E5HP-5020	Decal, Warning (Used On SG24/E3HP50 and SG24/E3HP60 Only)	1

Propane Conversion Assembly SG24/GHP Series Surface Grinder [Equipped With Propane Converted Engine]

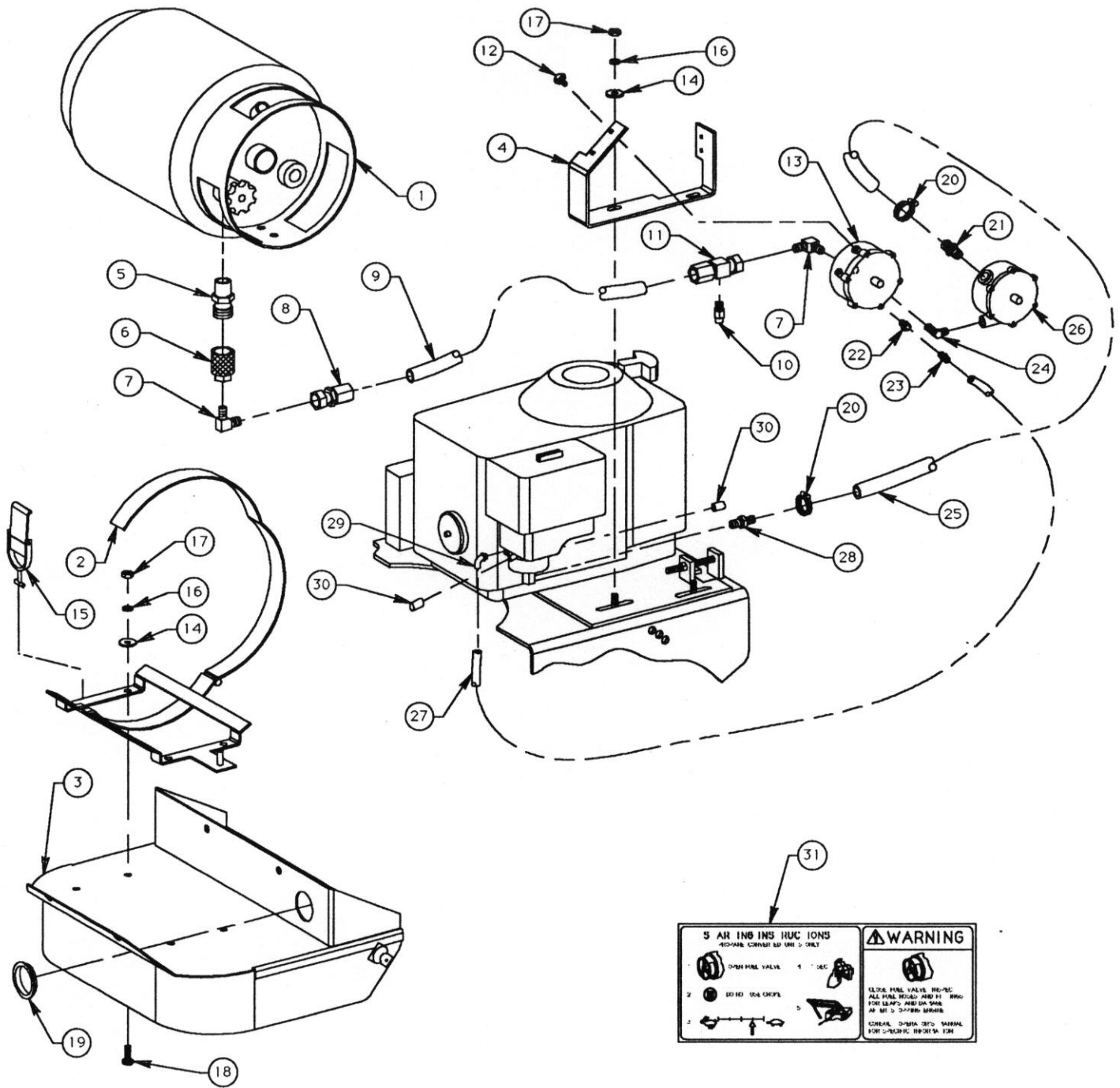

Propane Conversion Assembly

SG24/GHP Series Surface Grinder

[Equipped With Propane Converted Engine]

Reference Number	PART NUMBER	DESCRIPTION	QTY
1	5550	Cylinder, Propane	1
2	TB-4	Bracket, Mounting, Propane Cylinder	1
3	SG24-0210	Cover, V-Belt	1
4	SG24-0290	Bracket, Mounting, Propane Valves	1
5	7141M	Adapter	1
6	7141F	Connector	1
7	149F-6-4	Fitting, 90°	2
8	4401-6S	Fitting, HP Straight	1
9	FC321-06	Hose	1
10	3865	Valve, Relief	1
11	HC8346	Fitting	1
12	15040500	Screw, Cap, 1/4-20 UNC x 5/8", Plated, Grade 5	4
13	VFF30-2-4	Fuelock, Filter, Vacuum	1
14	17060000	Washer, Flat, 3/8", Plated	2
15	TB-2-60	Toggle	1
16	16060000	Washer, Lock 3/8", Plated	6
17	18060000	Nut, Hexagon, 3/8-16 UNC, Plated	6
18	36060800	Screw, Truss Head, 3/8-16 UNC x 1", Plated	4
19	SB-200-26	Grommet	1
20	56100000	Clamp, Hose, 5/8"	2
21	33SB	Nipple, Hose	1
22	AF4-66	Backcheck, Vacuum	1
23	11SB	Nipple, Hose	1
24	2247-4-4S	Elbow	1
25	501-123	Hose, Fuel	1
26	T60-G	Regulator, Fuel	1
27	506-009	Hose, Vacuum	1
28	2F-256	Spud	1
29	2F-158	Fitting	1
30	650-002	Cap, Vacuum	2
31	SG24-5060	Decal, Propane Starting Instruction	1

Replacement Parts Diagram/Installation Safety And Dust Shield Assembly SG24 Series Surface Grinder

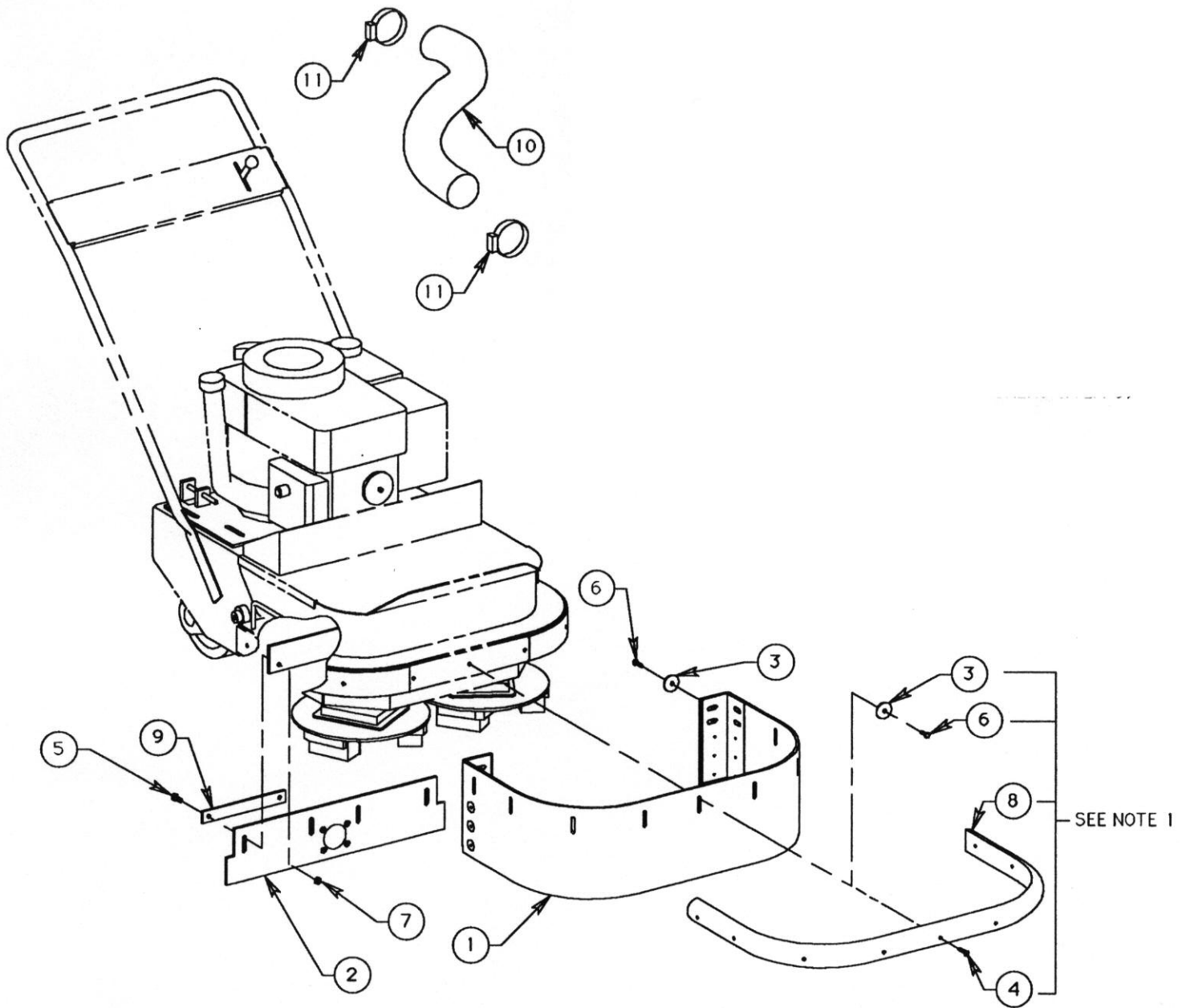

Replacement Parts Diagram/Installation Safety And Dust Shield Assembly SG24 Series Surface Grinder

Reference Number	PART NUMBER	DESCRIPTION	QTY
1	SG24-0230	Skirt, Grinder	1
2	SG24-0350	Skirt, Assembly	1
3	49040000	Washer, Fender 1/4"	2
4	27040800	Screw, Countersunk 1/4-20 UNC x 1", Plated	9
5	15050700	Screw, CAP 5/16-18 UNC x 7/8", Plated	4
6	15040700	Screw, CAP 1/4-20 UNC x 7/8", Plated	2
7	53050000	Nut, Hex 5/16-18 UNC, Nylock®, Plated	4
8	SG24-0220	Bumper, Rubber	1
9	SG24-0370	Strap, Support	2
10	SG24-0380	Hose, Vacuum	1
11	56480000	Clamp, Hose	2

NOTE:

- 1) Optional installation: Install Skirt (item 1) with either (9) countersunk cap screws (item 4) and reinstall Bumper (item 8) or with (9) washers (item 3) and (9) hex head cap screws (item 6)
- 2) Install Hose (item 10) to 3" OD tube welded to Grinder and to tube on Skirt (item 2) with hose clamps (items 11)

Lubrication Diagram

SG24 Series Surface Grinder

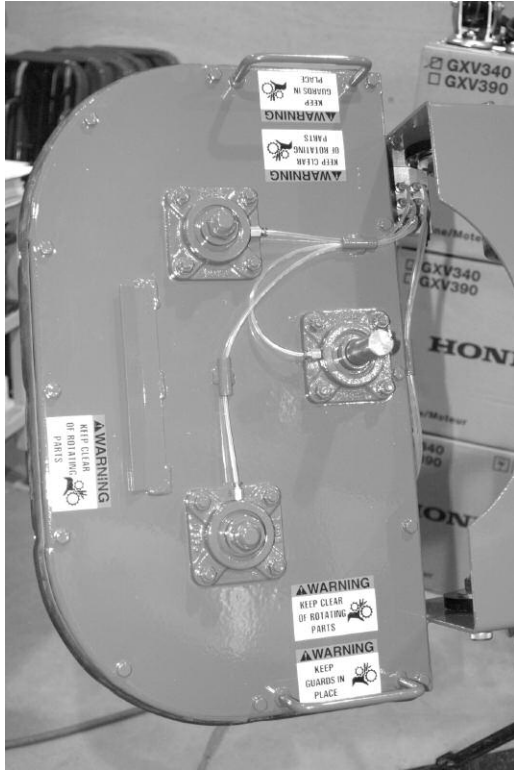

**Top of the SG24
Dual head Surface Grinder**



**Bottom of the SG24
Dual head Surface Grinder**

Scarifier Assembly SG24 Series Surface Grinders

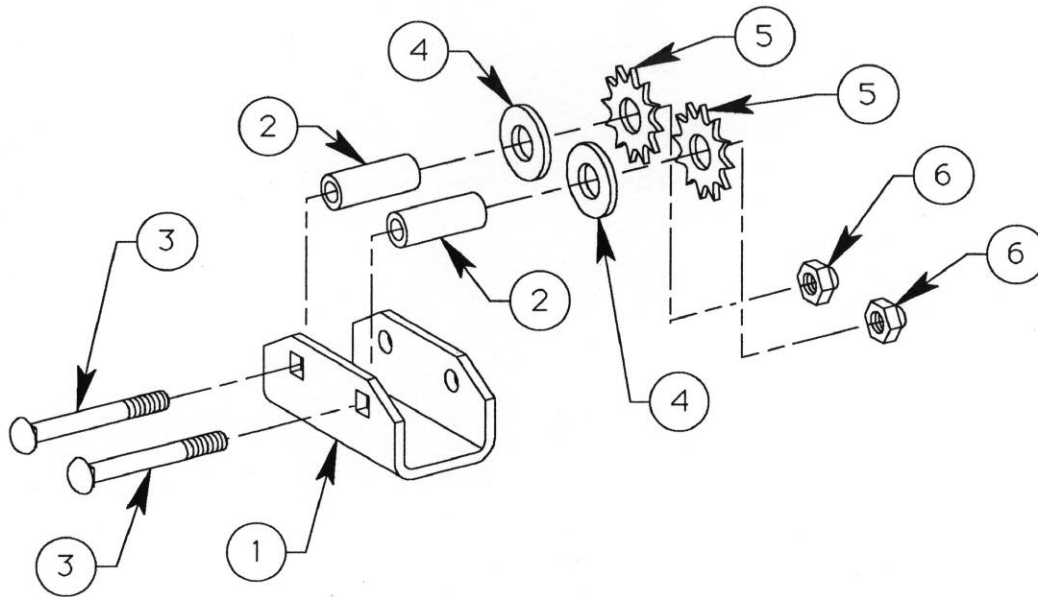

Cutter Assembly SCRAPE-R-TACH[®] Coating Removal System SG24 Series Surface Grinders

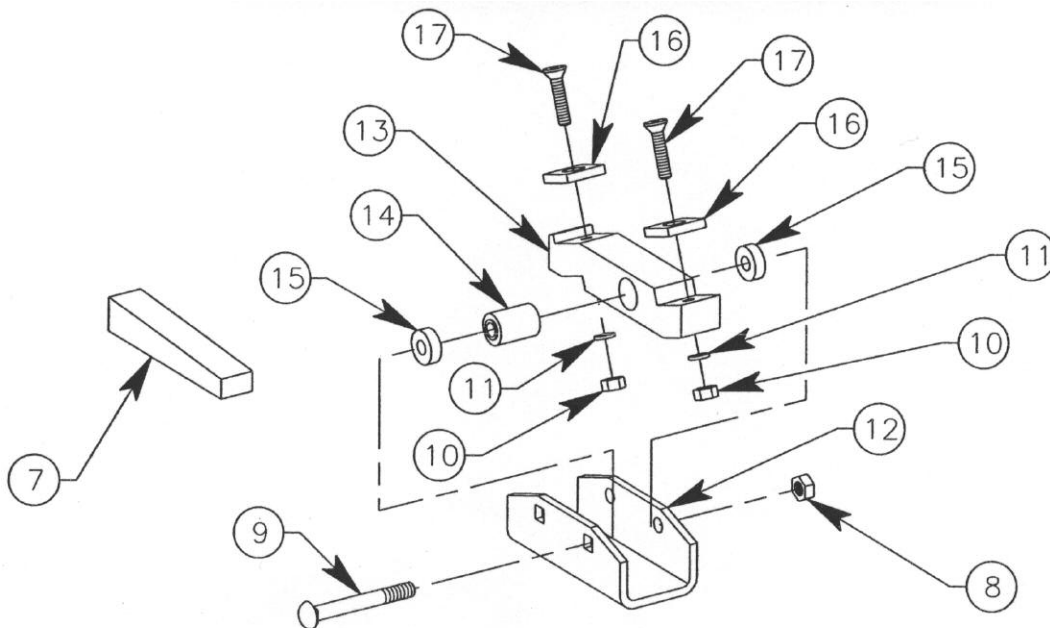

Scarifier Assembly SG24 Series Surface Grinders

Reference Number	PART NUMBER	DESCRIPTION	QTY
1	SG24-1900-012	Housing	1
2	SG24-1600-020	Bushing	2
3	87052000	Bolt, carriage, 5/16-18 UNC x 2 1/2" UNC, Plated, Grade 5	2
4	SG24-4000	Washer, Flat, 5/8", Heat Treated, Plated	*
5	SP8-3000	Flail, Star, Heat Treated Steel	**
	SP8-3100	Flail, Beam, Heat Treated Steel	**
	SP8-3200	Flail, Pentagonal, Carbide Tipped	**
6	53050000	Nut, Hexagon, 5/16-18 UNC, Nylock®, Plated	2
7	SG24-1800	Wedge, Plastic	1
<p>*QTY(12) Required with SP8-3000 and SP8-3100, Flails *QTY(8) Required with SP8-3200 Flails **QTY(12) Required with SP8-3000 and SP8-3100, Flails **QTY(8) Required with SP8-3200 Flails</p>			

Cutter Assembly **SCRAPE-R-TACH**® Coating Removal System SG24 Series Surface Grinders

Reference Number	PART NUMBER	DESCRIPTION	QTY
7	SG24-1800	Wedge, Plastic	1
8	53050000	Nut, Hexagon, 5/16-18 UNC, Nylock®, Plated	1
9	87052000	Bolt, Carriage, 5/16-18 UNC x 2-1/2", Plated, Grade 5	1
10	18040000	Net, Hexagon, 1/4-20 UNC, Plated	2
11	16040000	Washer, Lock, 1/4, Plated	2
12	SG24-1900-010	Housing	1
13	SG24-1900-020	Holder, Insert	1
14	J-2005-2A	Mount, Rubber	1
15	SG24-1900-040	Spacer	2
16	SG24-1900-030	Insert, Tungsten Carbide	2
17	27041000	Screw, Countersunk, 1/4-20 UNC x 1-1/4"	2

Grinding Block Assembly DIAM-A-TACH[®] Diamond Grinding System SG24 Series Surface Grinders

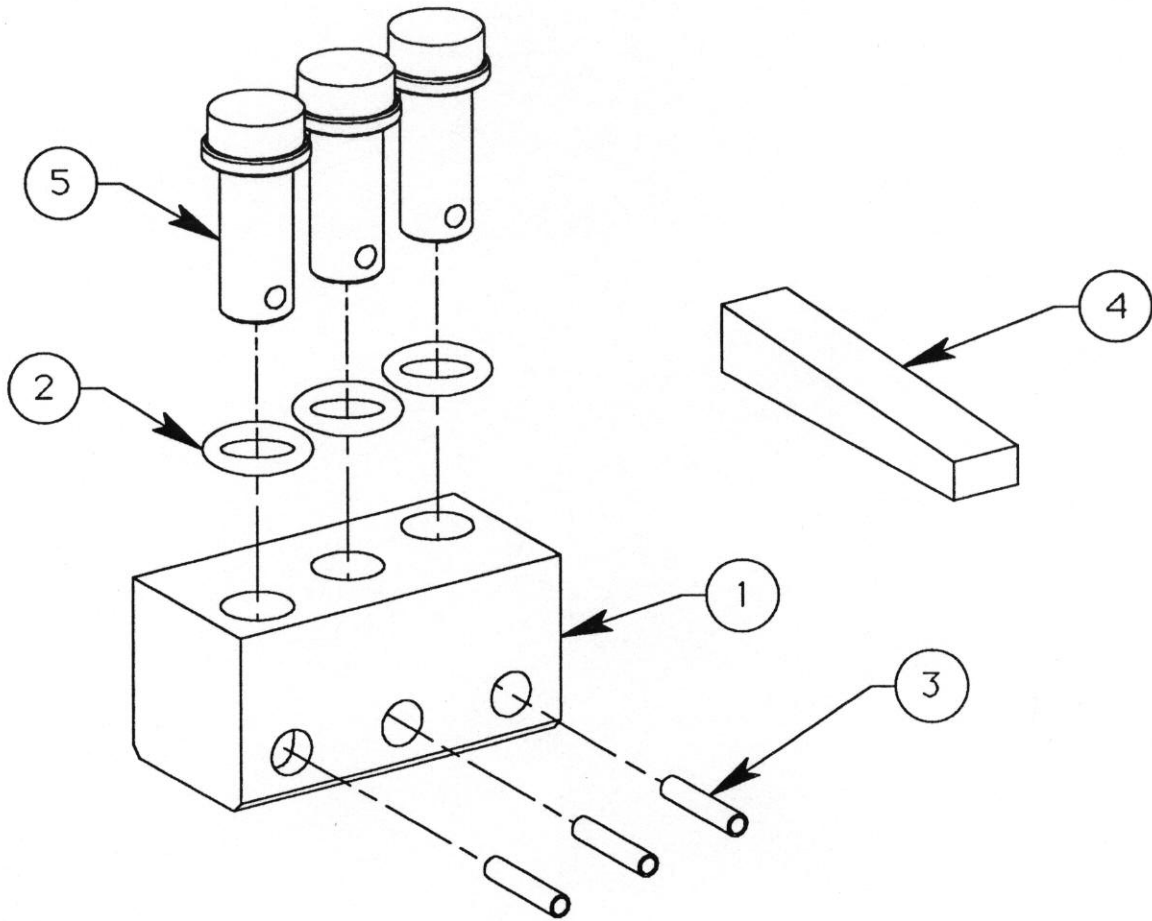

Grinding Block Assembly DIAM-A-TACH[®]

Diamond Grinding System

SG24 Series Surface Grinders

Reference Number	PART NUMBER	DESCRIPTION	QTY
1	SG24-2101-010	Block	1
2	SG24-2101-030	"O" Ring	3
3	83040900	Pin, Retaining (Stainless Steel)	3
4	SG24-1800	Wedge, Plastic	1
5	SG24-2100-020	Pin, Diamond, Purple Identification Color (40-50 Grit, For Aggress Grinding Use)	3
	SG24-2101-020	Pin, Diamond, Yellow Identification Color (40-50 Grit, For General Purpose Use)	3
	SG24-2102-020	Pin, Diamond, Black Identification Color (40-50 Grit, For Epoxy Morta and Asphalt Use)	3
	SG24-2103-020	Pin, Diamond, Green Identification Color (40-50 Grit, For Green Concrete And Asphalt Use)	3
	SG24-2104-020	Pin, Diamond, Red Identification Color (40-50 Grit, For Final Grinding/Polishing Use)	3

Replacement Part Diagrams SG12 Series Surface Grinder

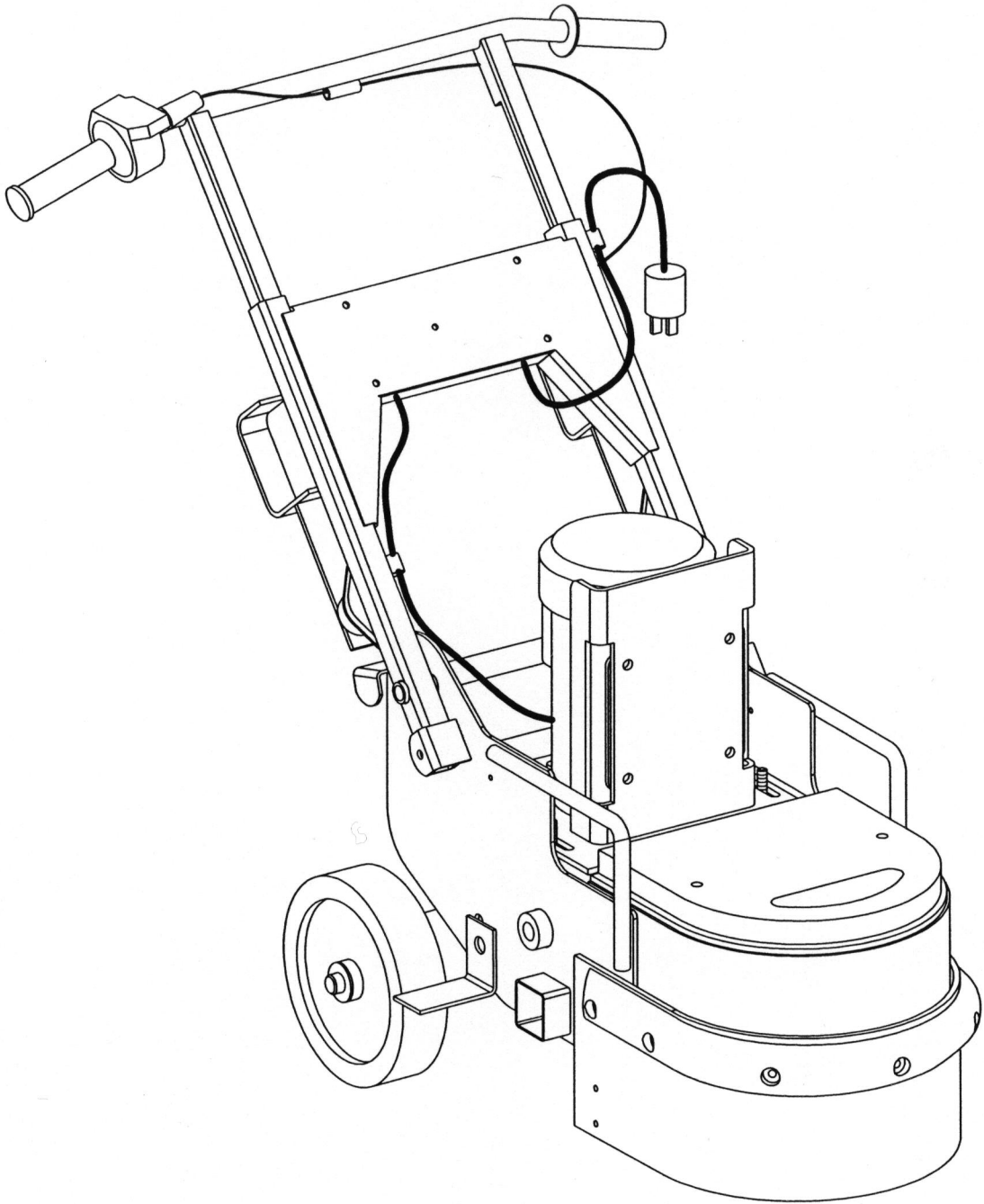

Frame Assembly SG12/E Surface Grinder

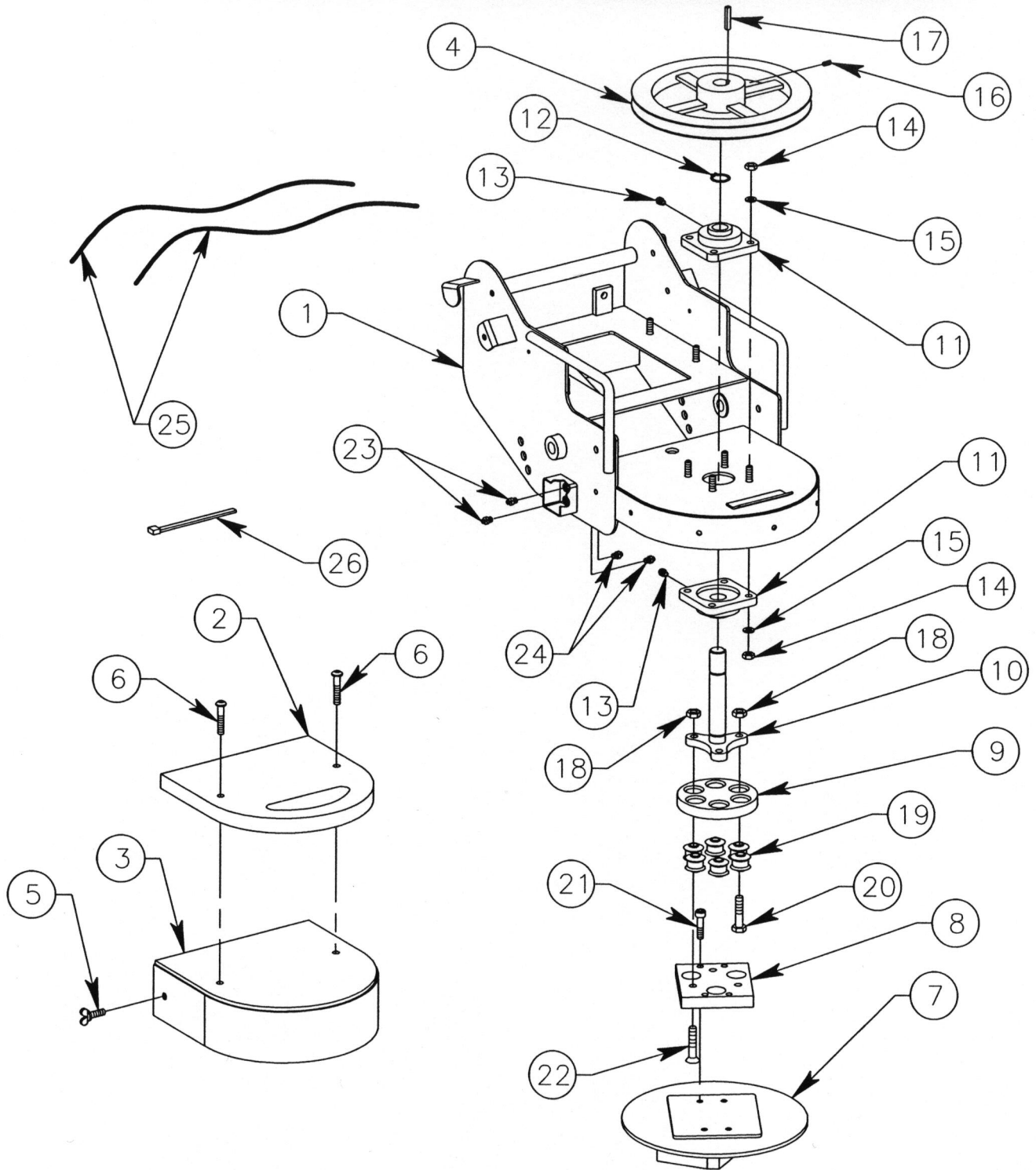

Frame Assembly SG12/E Surface Grinder

Reference Number	PART NUMBER	DESCRIPTION	QTY
1	SG12-0010	Frame, Main	1
2	SG12-0360	Weight	1
3	SG12-0020	Cover, Belt	1
4	SG12-0410	Pulley	1
5	91060600	Screw, Thumb, 3/8-16 UNC x 3/4", Plated	2
6	34061600	Screw, Machine, Round Head, 3/8-16 UNC x 2", Plated	2
7	SG24-0140	Disc, Multi-Accessory, LH	1
8	SG24-0130	Bar, Mounting	1
9	SG24-0120	Disc, Mounting	1
10	SG12-0240	Shaft	1
11	FHSF 205-16G	Bearing	2
12	5160-98	Ring, Snap	2
13	SG12-0130	Connector, Grease, 1/4-28 UNF	2
14	18060000	Nut, Hexagon, 3/8-16 UNC, Plated	8
15	16060000	Washer, Lock, 3/8", Plated	8
16	31050600	Screw, Set, Cup Point, 5/16-18 UNC x 3/8" (Included with Reference Number 4)	1
17	63041200	Key, Square, 1/4" x 1/4" x 1-1/2"	1
18	53070000	Nut, Hexagon, Locking, 7/16-14 UNC, Plated	6
19	J-6250-2A	Mount, Rubber	6
20	15071600	Screw, Cap, 1/16-14 UNC x 2", Plated	3
21	60061200	Screw, Socket, 3/8-16 UNC x 1-1/2", Plated	4
22	27071800	Screw, Countersunk, 7/16-14 UNC x 2-1/4"	3
23	SP8-0590	Fitting, Grease, Straight	2
24	SG12-0120	Connector, Grease, 1/8 Pipe	2
25	SG12-0140	Hose, Grease, 5/32", Clear (13" Length)	2
26	660-0560	Tie, Nylon, 6" Long	1

Operator Handle Assembly SG12/E Surface Grinder [Used Up To Serial Number 25690]

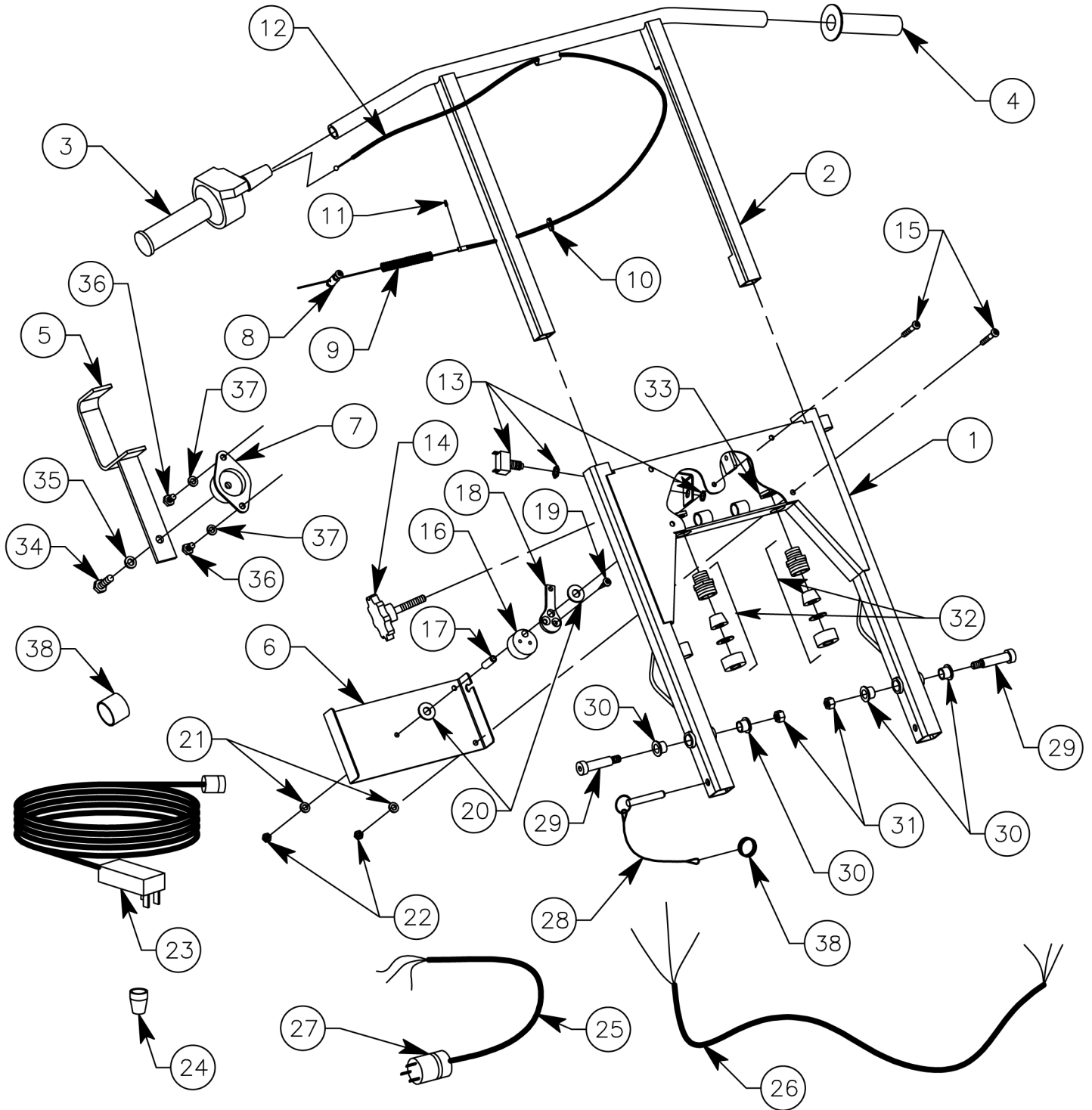

Operator Handle Assembly

SG12/E Surface Grinder

[Used Up To Serial Number 25690]

Reference Number	PART NUMBER	DESCRIPTION	QTY
1	SG12-0180	Handle, Lower	1
2	SG12-0110	Handle, Top	1
3	310-0030	Throttle, Twist Control, Plastic, Complete	1
4	SG12-0415	Grip, 7/8", Black	1
5	SG12-0280	Clamp, Hose	2
6	SG12-0190	Cover, Switch	1
7	660-0900	Mount, Rubber	2
8	WS-277	Assembly, Swivel	1
9	SG12-0350	Spring, Compression	1
10	FCS16-0300	Grommet	1
11	SG12-0340	E-Clip, 7/32" External	1
12	310-0081	Cable, Throttle	1
13	SG12-0330	Switch, 115V	1
14	SG12-0050	Knob Assembly	2
15	37041300	Screw, Machine, Pan Head Phillips, 1/4-20 UNC x 1-5/8", Plated	5
16	SG12-0170	Cam, Switch	1
17	SG12-0150	Tube, Pivot	1
18	SG12-0160	Lever, Switch	1
19	SG12-0380	Screw, Wood, Flat Head Phillips, #12 x 7/8"	2
20	17060000	Washer, Flat, 3/8", Plated	2
21	16040000	Washer, Lock, 1/4", Plated	5
22	90040000	Nut, Acron, 1/4-20 UNC, Plated	5
23	FCS16-1000	Extension Cord, GFCI	1
24	WIRE NUT Y	Nut, Wire, Yellow	3
25	SG12-0260	Cable, Switch To Plug	1
26	SG12-0270	Cable, Switch To Motor	1
27	HUB-4720C	Plug, Twist Lock, Male, 15A	1
28	FCS16-0210	Pin With Lanyard	2
29	62081400	Bolt, Shoulder, 1/2" x 1-3/4"	2
30	FCS16-0340	Bushing, Bronze, 1/2" ID	4
31	86060000	Nut, Hexagon, Flange, 3/8-16 UNC, Plated	2
32	CG-5050	Relief, Strain	2
33	801	Nut, Bulkhead (Included With Reference Number 32)	2
34	15060800	Screw, Cap, 3/8-16 UNC x 1", Plated	2
35	16060000	Washer, Lock, 3/8", Plated	2
36	15050400	Screw, Cap, 5/16-18 UNC x 1/2", Plated	4
37	16050000	Washer, Lock, 5/16", Plated	4
38	KIC-172	Ring, Kick Out	2

Operator Handle Assembly SG12/E Surface Grinder [Serial Number 25691 Thru 25694]

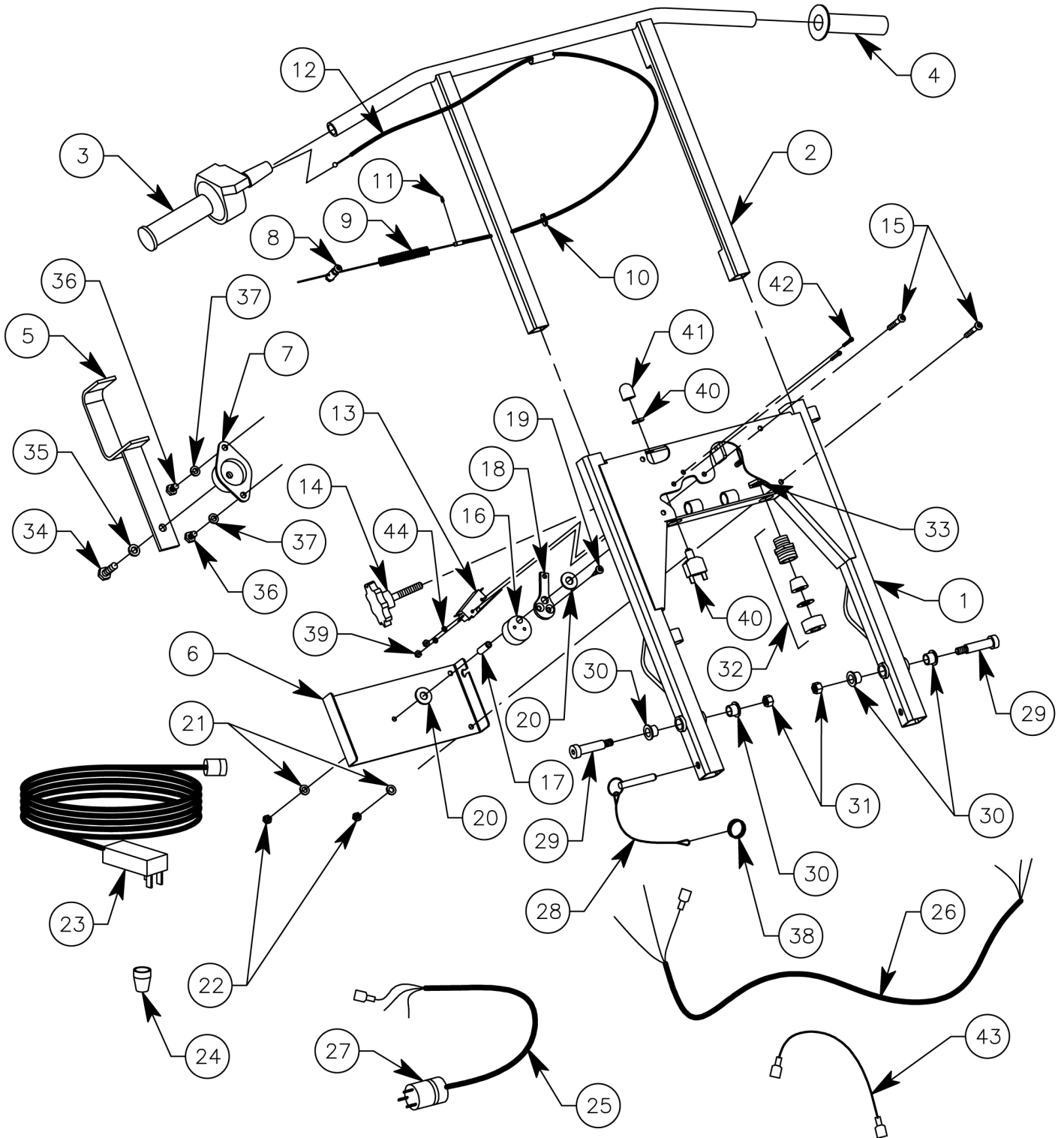

Operator Handle Assembly

SG12/E Surface Grinder

[Serial Number 25691 Thru 25694]

Reference Number	PART NUMBER	DESCRIPTION	QTY
1	SG12-0180	Handle, Lower	1
2	SG12-0110	Handle, Top	1
3	310-0030	Throttle, Twist Control, Plastic, Complete	1
4	SG12-0415	Grip, 7/8", Black	1
5	SG12-0280	Clamp, Hose	2
6	SG12-0190	Cover, Switch	1
7	660-0900	Mount, Rubber	2
8	WS-277	Assembly, Swivel	1
9	SG12-0350	Spring, Compression	1
10	FCS16-0300	Grommet	1
11	SG12-0340	E-Clip, 7/32" External	1
12	310-0081	Cable, Throttle	1
13	SG12-0070	Switch, 115V	1
14	SG12-0050	Knob Assembly	2
15	37041300	Screw, Machine, Pan Head Phillips, 1/4-20 UNC x 1-5/8", Plated	5
16	SG12-0170	Cam, Switch	1
17	SG12-0150	Tube, Pivot	1
18	SG12-0160	Lever, Switch	1
19	SG12-0380	Screw, Wood, Flat Head Phillips, #12 x 7/8"	2
20	17060000	Washer, Flat, 3/8", Plated	2
21	16040000	Washer, Lock, 1/4", Plated	5
22	90040000	Nut, Acron, 1/4-20 UNC, Plated	5
23	FCS16-1000	Extension Cord, GFCI	1
24	WIRE NUT Y	Nut, Wire, Yellow	3
25	SG12-0260	Cable, Switch To Plug	1
26	SG12-0270	Cable, Switch To Motor	1
27	HUB-4720C	Plug, Twist Lock, Male, 15A	1
28	FCS16-0210	Pin With Lanyard	2
29	62081400	Bolt, Shoulder, 1/2" x 1-3/4"	2
30	FCS16-0340	Bushing, Bronze, 1/2" ID	4
31	86060000	Nut, Hexagon, Flange, 3/8-16 UNC, Plated	2
32	CG-5050	Relief, Strain	2
33	801	Nut, Bulkhead (Included With Reference Number 32)	2
34	15060800	Screw, Cap, 3/8-16 UNC x 1", Plated	2
35	16060000	Washer, Lock, 3/8", Plated	2
36	15050400	Screw, Cap, 5/16-18 UNC x 1/2", Plated	4
37	16050000	Washer, Lock, 5/16", Plated	4
38	KIC-172	Ring, Kick Out	2
39	18010000	Hut, Hezagon, #6-32, Plated	2
40	SG12-0080	Circuit Breaker, 15 AMP	1
41	SG12-0090	Cover, Circuit Breaker	1
42	34010800	Screw, Machine, Pan Head Phillips, #6-32 UNC, x 1", Plated	2
43	SG12-0100	Wire, Jumper	1
44	58010000	Washer, Lock, External Tooth, #6	2

Operator Handle Assembly SG12/E Surface Grinder [Used Starting With Serial Number 25695]

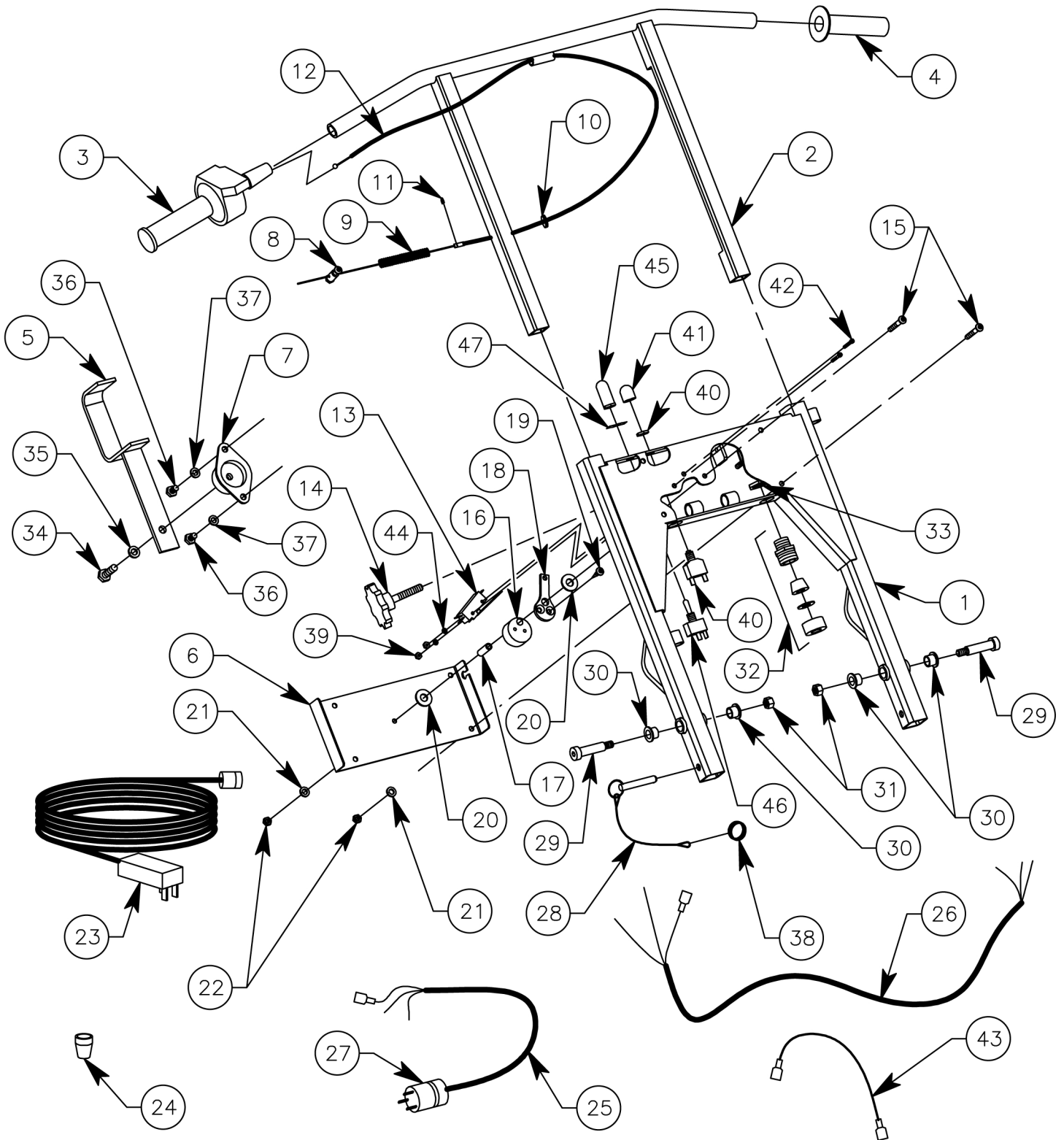

Operator Handle Assembly

SG12/E Surface Grinder

[Used Starting With Serial Number 25695]

Reference Number	PART NUMBER	DESCRIPTION	QTY
1	SG12-0181	Handle, Lower	1
2	SG12-0110	Handle, Top	1
3	310-0030	Throttle, Twist Control, Plastic, Complete	1
4	SG12-0415	Grip, 7/8", Black	1
5	SG12-0280	Clamp, Hose	2
6	SG12-0191	Cover, Switch	1
7	660-0900	Mount, Rubber	2
8	WS-277	Assembly, Swivel	1
9	SG12-0350	Spring, Compression	1
10	FCS16-0300	Grommet	1
11	SG12-0340	E-Clip, 7/32" External	1
12	310-0081	Cable, Throttle	1
13	SG12-0070	Switch, 115V	1
14	SG12-0050	Knob Assembly	2
15	37041300	Screw, Machine, Pan Head Phillips, 1/4-20 UNC x 1-5/8", Plated	5
16	SG12-0170	Cam, Switch	1
17	SG12-0150	Tube, Pivot	1
18	SG12-0160	Lever, Switch	1
19	SG12-0380	Screw, Wood, Flat Head Phillips, #12 x 7/8"	2
20	17060000	Washer, Flat, 3/8", Plated	2
21	16040000	Washer, Lock, 1/4", Plated	5
22	90040000	Nut, Acron, 1/4-20 UNC, Plated	5
23	FCS16-1000	Extension Cord, GFCI	1
24	WIRE NUT Y	Nut, Wire, Yellow	3
25	SG12-0260	Cable, Switch To Plug	1
26	SG12-0270 A	Cable, Switch To Motor	1
27	HUB-4720C	Plug, Twist Lock, Male, 15A	1
28	FCS16-0210	Pin With Lanyard	2
29	62081400	Bolt, Shoulder, 1/2" x 1-3/4"	2
30	FCS16-0340	Bushing, Bronze, 1/2" ID	4
31	86060000	Nut, Hexagon, Flange, 3/8-16 UNC, Plated	2
32	CG-5050	Relief, Strain	2
33	801	Nut, Bulkhead (Included With Reference Number 32)	2
34	15060800	Screw, Cap, 3/8-16 UNC x 1", Plated	2
35	16060000	Washer, Lock, 3/8", Plated	2
36	15050400	Screw, Cap, 5/16-18 UNC x 1/2", Plated	4
37	16050000	Washer, Lock, 5/16", Plated	4
38	KIC-172	Ring, Kick Out	2
39	12010000	Hut, #6-32 K-Lock	2
40	SG12-0080	Circuit Breaker, 15 AMP	1
41	SG12-0090	Cover, Circuit Breaker	1
42	34010800	Screw, Machine, Pan Head Phillips, #6-32 UNC, x 1", Plated	2
43	SG12-0100	Wire, Jumper	2
44			
45	SG12-0300-020	Cover, Master Switch	1
46	SG12-0300-010	Switch, Master Toggle	1
47	SG12-0300-030	Face Plate, ON/OFF	1

Electric Motor Assembly SG12/E Surface Grinder

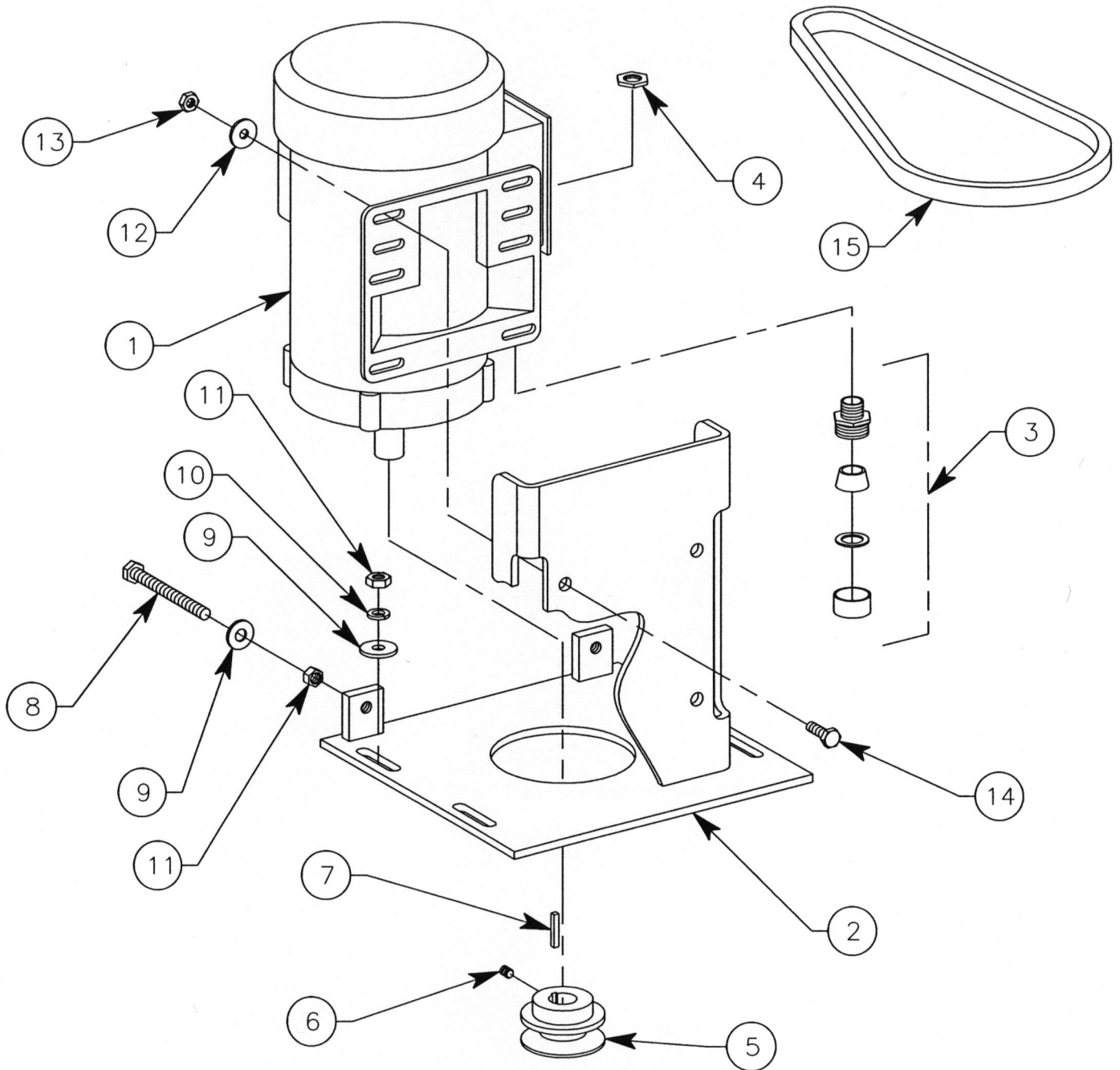

Electric Motor Assembly SG12/E Surface Grinder

Reference Number	PART NUMBER	DESCRIPTION	QTY
1	SG12-0030	Motor, Electric, 1-1/2 HP, 115 VAC	1
2	SG12-0250	Mount, Electric Motor	1
3	CG-5050	Relief, Strain	1
4	801	Nut, Bulkhead (Included With Reference Number 3)	Reference
5	SG12-0400	Pulley	1
6	31050600	Screw, Set, Cup Point, 5/16-18 UNC x 3/8" (Included With Reference Number 5)	1
7	63030800	Key, Square, 3/16" x 3/16" x 1"	1
8	CS8-0470	Screw, Cap, 3/8-16 UNC x 3-1/2", Full Thread, Plated	2
9	17060000	Washer, Flat, 3/8", Plated	6
10	16060000	Washer, Lock, 3/8", Plated	4
11	18060000	Nut, Hexagon, 3/8-16 UNC, Plated	6
12	17040000	Washer, Flat, 1/4", Plated	4
13	53050000	Nut, Hexagon, Nylock®, 5/16-18 UNC, Plated	4
14	15050800	Screw, Cap, 5/16-18 UNC x 1", Plated	4
15	B45	Belt, V Type	1

Wheel Dolly Assembly SG12/E Surface Grinder

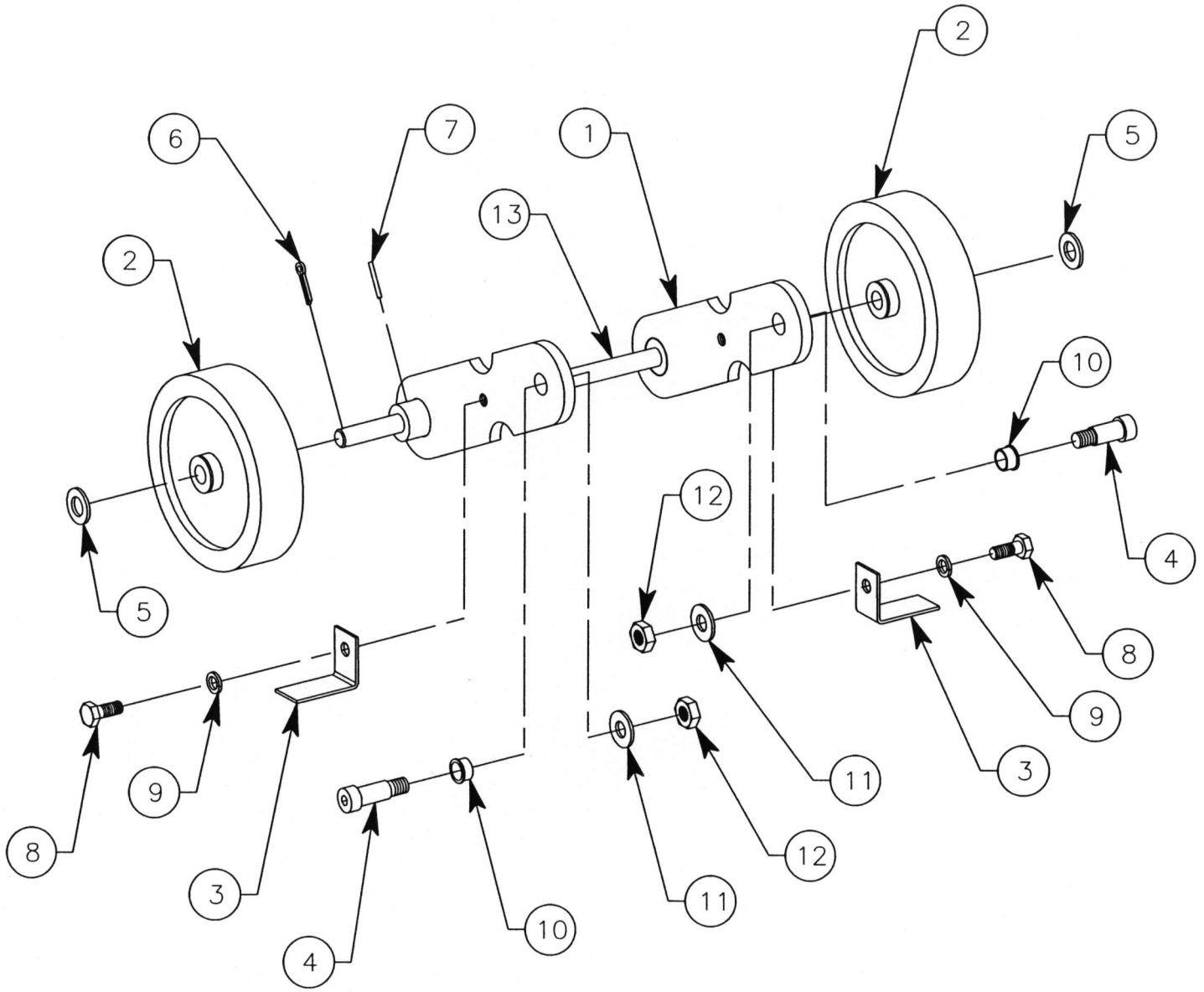

Wheel Dolly Assembly SG12/E Surface Grinder

Reference Number	PART NUMBER	DESCRIPTION	QTY
1	SG24-0190	Arm, Swing	2
2	SG24-0260	Wheel	2
3	SG12-0370	Scraper, Wheel	2
4	62121200	Bolt, Shoulder, 3/4-10 UNC x 1-1/2"	2
5	17120000	Washer, Flat, 3/4", Plated	2
6	22022400	Pin, Cotter, 5/32" x 1-1/2", Plated	2
7	20031200	Pin, Roll, 3/16" x 1-1/2"	2
8	15081000	Screw, Cap, 1/2-13 UNC x 1-1/4", Plated	2
9	16080000	Washer, Lock, 1/2", Plated	2
10	660-0410	Bearing, Oilite®	2
11	17100000	Washer, Flat, 5/8", Plated	2
12	18100000	Nut, Hexagon, 5/8-11 UNC, Plated	2
13	SG12-0200	Axle, Plated	1

Plastic Body Series 314 Magura® Throttle Control Assembly SG12/E Surface Grinder

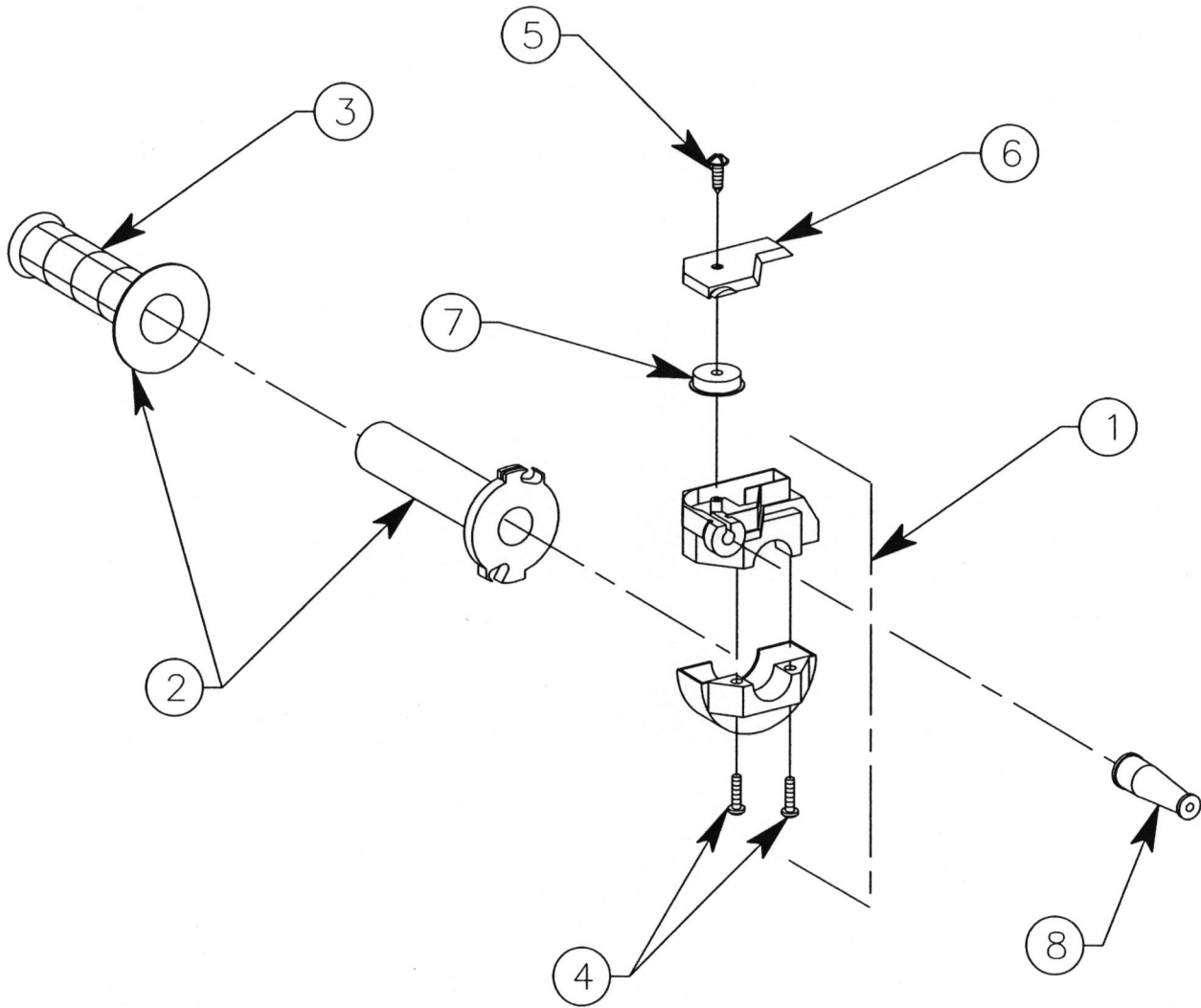

Plastic Body Series 314
Magura® Throttle Control Assembly
SG12/E Surface Grinder

Reference Number	PART NUMBER	DESCRIPTION	QTY
1	310-0030-010-A	Body Assembly, (Includes P/N 310-0030-040, Qty 2)	1
2	310-0030-020-A	Tube, Throttle (Includes P/N 310-0020-030)	1
3	310-0020-030	Grip, Handle	1
4	310-0030-040	Screw, Pan Head, M5 x 20	2
5	310-0030-050	Screw, Self Tapping	1
6	310-0030-060	Cover, Top	1
7	310-0030-070	Sheave, Roller	1
8	310-0020-080	Boot, Rubber	1

Safety And Dust Shield Assembly SG12/E Surface Grinder

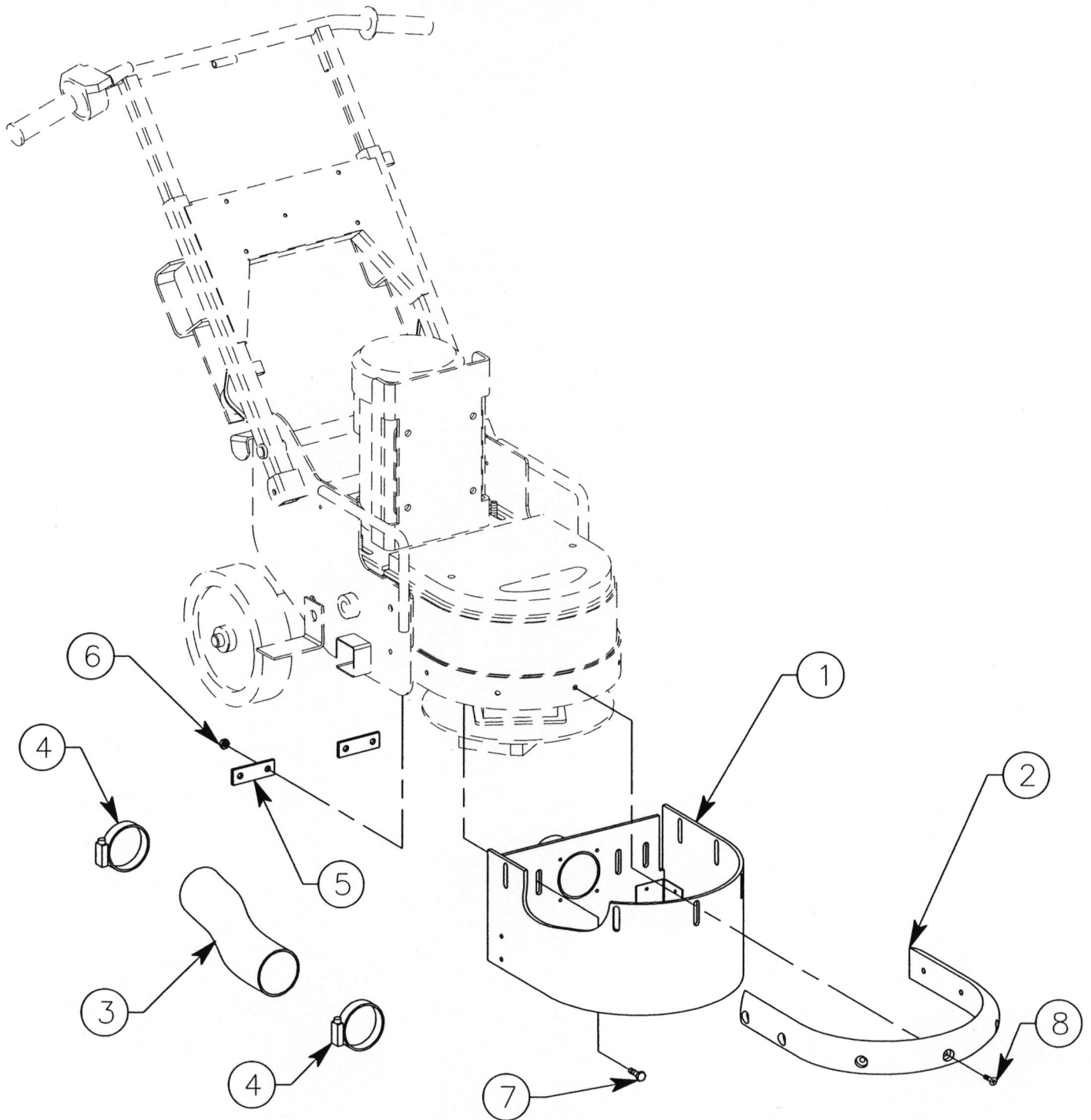

Safety And Dust Shield Assembly SG12/E Surface Grinder

Reference Number	PART NUMBER	DESCRIPTION	QTY
1	SG12-0230	Skirt Assembly	1
2	SG12-0220	Bumper, Rubber	1
3	SG12-0060	Hose, Vacuum	1
4	56480000	Clamp, Hose, 3"	2
5	SG12-0040	Strap, Skirt	2
6	53050000	Nut, Hexagon, Nylock®, 5/16-18 UNC, Plated	4
7	15050700	Screw, Cap, 5/16-18 UNC x 7/8", Plated	4
8	61040800	Screw, Countersunk, 1/4-20 UNC x 1", Plated	7