

OPERATION MANUAL



WHISPERWATT™ SERIES MODEL DCA45SSIU4F 60 Hz GENERATOR (ISUZU 4LE2X DIESEL ENGINE)

Revision #8 (11/01/21)

To find the latest revision of this publication or
associated parts manual, visit our website at:
www.mqpower.com



THIS MANUAL MUST ACCOMPANY THE EQUIPMENT AT ALL TIMES.

PROPOSITION 65 WARNING



**DCA45SSIU4F
60 Hz Generator**

Proposition 65 Warning 2
Table Of Contents 3
Safety Decals 4
Safety Information 5–10
Specifications 11
Dimensions 12
Installation 14–15
General Information 16
Major Components 17
Engine/Generator Control Panel 18–19
Output Terminal Panel Familiarization 20–22
Load Application 23
Generator Outputs 24
Generator Outputs/Gauge Reading 25
Output Terminal Panel Connections 26–27
Inspection/Setup 28–32
Generator Start-Up Procedure (Manual) 33–34
Generator Start-Up Procedure (Auto Mode) 35
Generator Shutdown Procedure 36
Maintenance 37–46
Troubleshooting (Diagnostics) 47
Troubleshooting (Generator) 48
Troubleshooting (Engine) 49–50
Generator Wiring Diagram (M1814100903C) 51
Engine Wiring Diagram S/N 7251795 And Below.. 52
Engine Wiring Diagram S/N 7251796 ~ 7254612.. 53
Engine Wiring Diagram (M1814100423) 54
Controller Wiring Diagram (M1814100903C) 55
Battery Charger Wiring Diagram 56
Jacket Water Heater Wiring Diagram 57

NOTICE

Specifications are subject to change without notice.

SAFETY DECALS

Safety decals are attached to the generator as shown in Figure 1. Keep these safety decals clean at all times. When the safety decals become worn or damaged, contact your nearest dealer or the Multiquip Parts Department.

NOTICE
For safety decals part numbers, reference parts manual.

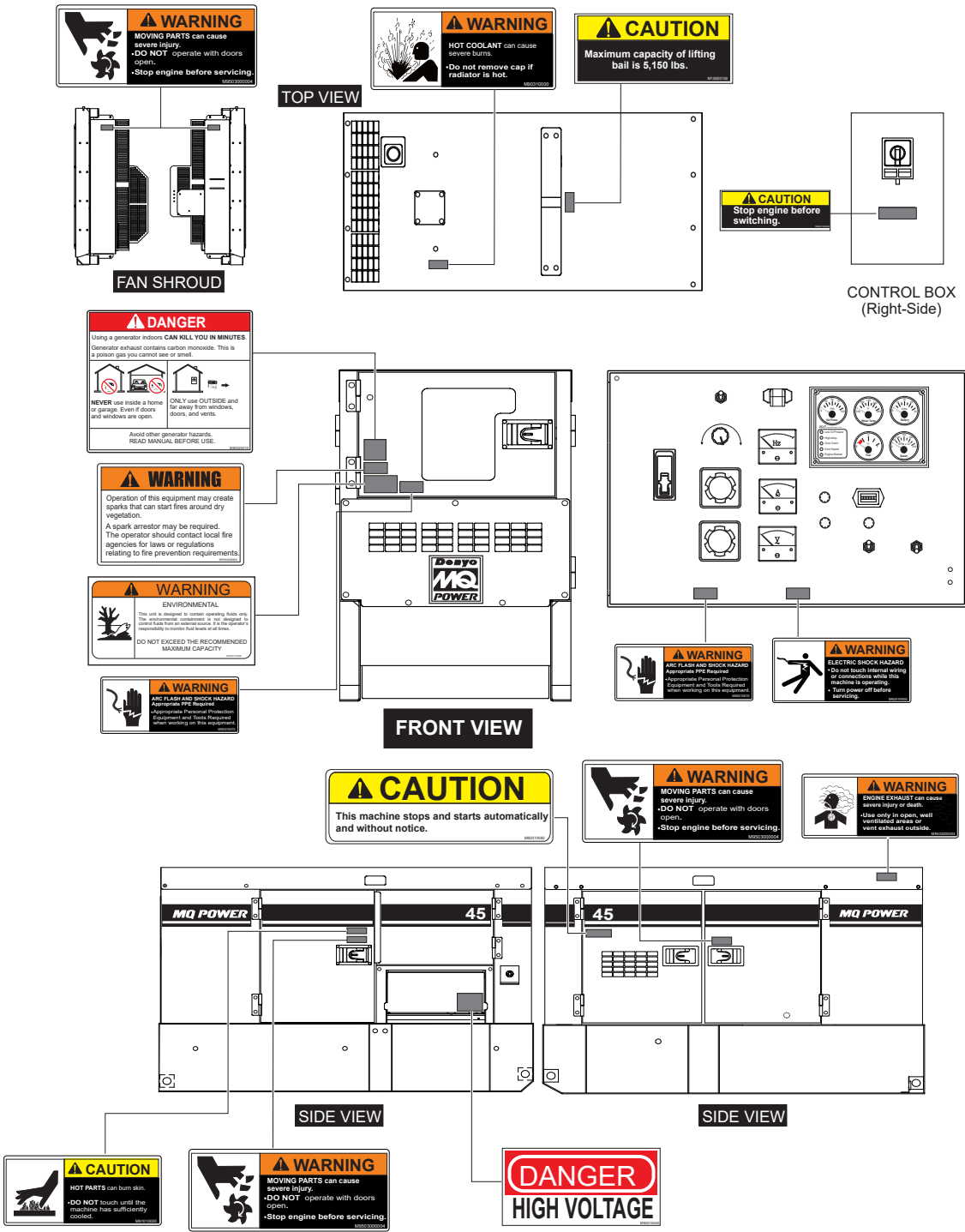

Figure 1. Safety Decals

SAFETY INFORMATION

Do not operate or service the generator before reading the entire manual. Safety precautions should be followed at all times when operating this generator. Failure to read and understand the safety messages and operating instructions could result in injury to yourself and others.

SAFETY MESSAGES

The four safety messages shown below will inform you about potential hazards that could injure you or others. The safety messages specifically address the level of exposure to the operator and are preceded by one of four words: **DANGER**, **WARNING**, **CAUTION** or **NOTICE**.

SAFETY SYMBOLS

 **DANGER**

Indicates a hazardous situation which, if not avoided, **WILL** result in **DEATH** or **SERIOUS INJURY**.

 **WARNING**

Indicates a hazardous situation which, if not avoided, **COULD** result in **DEATH** or **SERIOUS INJURY**.







 **CAUTION**

Indicates a hazardous situation which, if not avoided, **COULD** result in **MINOR** or **MODERATE INJURY**.

NOTICE

Addresses practices not related to personal injury.

Potential hazards associated with the operation of this generator will be referenced with hazard symbols which may appear throughout this manual in conjunction with safety messages.

Symbol	Safety Hazard
	Lethal exhaust gas hazards
	Explosive fuel hazards
	Burn hazards
	Overspeed hazards
	Rotating parts hazards
	Pressurized fluid hazards
	Electric shock hazards

SAFETY INFORMATION

GENERAL SAFETY

CAUTION

- **NEVER** operate this generator without proper protective clothing, shatterproof glasses, respiratory protection, hearing protection, steel-toed boots and other protective devices required by the job or city and state regulations.



- **NEVER** operate this generator when not feeling well due to fatigue or illness, or when on medication.
- **NEVER** operate this generator under the influence of drugs or alcohol.



- **ALWAYS** check the generator for loosened threads or bolts before starting.
- **NEVER** use the generator for any purpose other than its intended purposes or applications.

NOTICE

- This generator should only be operated by trained and qualified personnel 18 years of age and older.
- Whenever necessary, replace nameplate, operation and safety decals when they become difficult to read.
- Manufacturer does not assume responsibility for any accident due to equipment modifications. Unauthorized modification of the generator will void all warranties.
- **NEVER** use accessories or attachments that are not recommended by MQ Power for this generator. Damage to the generator and/or injury to the user may result.
- **ALWAYS** know the location of the nearest **fire extinguisher**.
- **ALWAYS** know the location of the nearest **first aid kit**.



- **ALWAYS** know the location of the nearest phone or **keep a phone on the job site**. Also, know the phone numbers of the nearest **ambulance, doctor, and fire department**. This information will be invaluable in the case of an emergency.

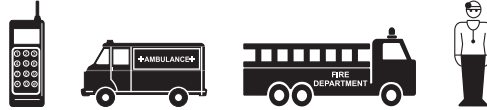

GENERATOR SAFETY

DANGER

- **NEVER** operate the generator in an explosive atmosphere or near combustible materials. An explosion or fire could result causing **severe bodily harm or even death**.



WARNING

- **NEVER** disconnect any **emergency or safety devices**. These devices are intended for operator safety. Disconnection of these devices can cause **severe injury, bodily harm or even death**. Disconnection of any of these devices will void all warranties.

CAUTION

- **NEVER** lubricate components or attempt service on a **running generator**.

NOTICE

- **ALWAYS** ensure the generator is on level ground before use.
- **ALWAYS** keep the generator in proper running condition.
- Fix damage to the generator and replace any broken parts immediately.
- **ALWAYS** store the generator properly when it is not being used. The generator should be stored in a clean, dry location out of the reach of children and unauthorized personnel.

SAFETY INFORMATION

ENGINE SAFETY

DANGER

- The engine fuel exhaust gases contain poisonous carbon monoxide. This gas is colorless and odorless, and can cause **death** if inhaled.
- The engine of this generator requires an adequate, free flow of cooling air. **NEVER** operate this equipment in any enclosed or narrow area where free flow of the air is restricted. If the air flow is restricted it will cause injury to people and property and serious damage to the equipment or engine.



- When operating the generator outdoors, **DO NOT** place the generator near doors, windows or vents that could allow carbon monoxide to enter and build up in occupied spaces.

WARNING

- **NEVER** place hands or fingers inside the engine compartment when the engine is running.
- **NEVER** operate the engine with heat shields or guards removed.
- Keep fingers, hands, hair and clothing away from all moving parts to prevent injury.
- **NEVER** operate the generator with the doors open. Stop the engine before servicing.
- **DO NOT** remove the radiator cap while the engine is hot. High pressure boiling water will gush out of the radiator and severely scald any persons in the general area of the generator.
- **DO NOT** remove the coolant drain plug while the engine is hot. Hot coolant will gush out of the coolant tank and severely scald any persons in the general area of the generator.
- **DO NOT** drain the engine oil while the engine is hot. Hot oil will gush out and severely scald any persons near the generator.



- Operation of the generator may create sparks that can start fires around dry vegetation. A spark arrestor may be required. The operator should contact local fire agencies for laws or regulations relating to fire prevention requirements.

CAUTION

- **NEVER** touch the hot exhaust manifold, muffler or cylinder. Allow these parts to cool before servicing the generator.



NOTICE

- **NEVER** run the engine without an air filter or with a dirty air filter. Severe engine damage may occur. Service the air filter frequently to prevent engine malfunction.
- **NEVER** tamper with the factory settings of the engine or engine governor. Damage to the engine or generator can result if operating in speed ranges above the maximum allowable.



- Wet stacking is a common problem with diesel engines which are operated for extended periods with light or no load applied. When a diesel engine operates without sufficient load (less than 30-35% of the rated output), it will not operate at its optimum temperature. This will allow unburned fuel to accumulate in the exhaust system, which can foul the fuel injectors, engine valves and exhaust system, including turbochargers, and reduce the operating performance.

In order for a diesel engine to operate at peak efficiency, it must be able to provide fuel and air in the proper ratio and at a high enough engine temperature for the engine to completely burn all of the fuel.

Wet stacking does not usually cause any permanent damage and can be alleviated if additional load is applied to relieve the condition. It can reduce the system performance and increase maintenance. Applying an increasing load over a period of time until the excess fuel is burned off and the system capacity is reached usually can repair the condition. This can take several hours to burn off the accumulated unburned fuel.

SAFETY INFORMATION

■ State Health Safety Codes and Public Resources Codes specify that in certain locations, spark arresters must be used on internal combustion engines that use hydrocarbon fuels. A spark arrester is a device designed to prevent accidental discharge of sparks or flames from the engine exhaust. Spark arresters are qualified and rated by the United States Forest Service for this purpose. In order to comply with local laws regarding spark arresters, consult the engine distributor or the local Health and Safety Administrator.

FUEL SAFETY

DANGER

- **NEVER** start the engine near spilled fuel or combustible fluids. Diesel fuel is extremely flammable and its vapors can cause an explosion if ignited.
- **ALWAYS** refuel in a well-ventilated area, away from sparks and open flames.
- **ALWAYS** use extreme caution when working with **flammable** liquids.
- **NEVER** fill the fuel tank while the engine is **running** or **hot**.
- **NEVER** overfill the fuel tank. Spilled fuel can ignite if it comes into contact with hot engine parts or sparks from the ignition system.
- Store fuel in appropriate containers, in well-ventilated areas and away from sparks and flames.
- **NEVER** use fuel as a cleaning agent.
- **NEVER** smoke around or near the equipment. Fire or explosion could result from fuel vapors or if fuel is spilled on a hot engine.



TOWING SAFETY

CAUTION

- Check with your local county or state safety towing regulations, in addition to meeting **Department of Transportation (DOT) Safety Towing Regulations**, before towing your generator.





- Refer to the MQ Power trailer manual for additional safety information.
- In order to reduce the possibility of an accident while transporting the generator on public roads, **ALWAYS** make sure that the trailer that supports the generator and the towing vehicle are both mechanically sound and in good operating condition.
- **ALWAYS** shut down the engine before transporting.
- Make sure the hitch and coupling of the towing vehicle are rated equal to or greater than the trailer **gross vehicle weight rating**.
- **ALWAYS** inspect the hitch and coupling for wear. **NEVER** tow a trailer with defective hitches, couplings, chains, etc.
- Check the tire air pressure on both the towing vehicle and the trailer. **Inflate trailer tires as indicated on side wall of tire**. Also check the tire tread wear on both vehicles.
- **ALWAYS** make sure the trailer is equipped with **safety chains**.
- **ALWAYS** properly attach the trailer's safety chains to the towing vehicle.
- **ALWAYS** make sure the vehicle and trailer directional, backup, brake, and trailer lights are connected and working properly.
- DOT requirements include the following:
 - Connect and test electric brake operation.
 - Secure portable power cables in cable tray with tie wraps.
- The maximum speed for highway towing is **55 MPH** unless posted otherwise. Recommended off-road towing is not to exceed **15 MPH** or less depending on the type of terrain.
- Avoid sudden stops and starts. These can cause skidding or jackknifing. Smooth, gradual starts and stops will improve towing.
- Avoid sharp turns to prevent rolling.
- The trailer should be adjusted to a level position at all times when towing.

SAFETY INFORMATION

- Raise and lock the trailer wheel stand in the upright position when towing.
- Place **chock blocks** underneath the wheels to prevent **rolling** while parked.
- Place **support blocks** underneath the trailer's bumper to prevent **tipping** while parked.
- Use the trailer's swivel jack to adjust the trailer height to a level position while parked.

ELECTRICAL SAFETY

DANGER

- **NEVER** touch the output terminals during operation. Contact with the output terminals during operation can cause **electrocution, electrical shock, or burn**. 
- The electrical voltage required to operate the generator can cause **severe injury or even death** through physical contact with live circuits. Turn the generator and all circuit breakers **OFF** before performing maintenance on the generator or making contact with the output terminals.
- **NEVER** insert any objects into the output receptacles during operation. This is extremely dangerous. The possibility exists of **electrical shock, electrocution or death**. 
- Backfeed to a utility system can cause **electrocution** and/or property damage. **NEVER** connect the generator to a building's electrical system without a transfer switch or other approved device. All installations should be performed by a **licensed electrician** in accordance with all applicable laws and electrical codes. Failure to do so could result in electrical shock or burn, causing **serious injury or even death**. 

Power Cord/Cable Safety

DANGER

- **NEVER** let power cords or cables **lay in water**.
- **NEVER stand in water** while AC power from the generator is being transferred to a load.

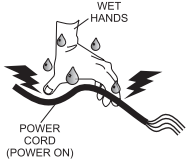
- **NEVER** use **damaged** or **worn** cables or cords when connecting equipment to the generator. Inspect the insulation for cuts.
- **NEVER** grab or touch a live power cord or cable with **wet hands**. The possibility exists of **electrical shock, electrocution or death**. 
- Make sure power cables are securely connected to the generator's output receptacles. Incorrect connections may cause electrical shock and damage to the generator.

NOTICE

- **ALWAYS** make certain that the proper power or extension cord has been selected for the job. See the Cable Selection Chart in this manual.

Grounding Safety

DANGER

- **ALWAYS** make sure that electrical circuits are properly grounded to a suitable earth ground (ground rod) per the National Electrical Code (NEC) and local codes before operating the generator. **Severe injury or death by electrocution** can result from operating an ungrounded generator.
- **NEVER** use gas piping as an electrical ground.

BATTERY SAFETY

DANGER

- **DO NOT** drop the battery. There is a possibility that the battery will explode.
- **NEVER** expose the battery to open flames, sparks, cigarettes, etc. The battery contains combustible gases and liquids. If these gases and liquids come into contact with a flame or spark, an explosion could occur. 

WARNING

- **ALWAYS** wear safety glasses when handling the battery to avoid eye irritation. The battery contains acids that can cause injury to the eyes and skin. 
- Use well-insulated gloves when picking up the battery.

SAFETY INFORMATION

- **ALWAYS** keep the battery charged. If the battery is not charged, combustible gas will build up.
- **ALWAYS** recharge the battery in a well-ventilated environment to avoid the risk of a dangerous concentration of combustible gases.
- If the battery liquid (dilute sulfuric acid) comes into contact with **clothing or skin**, rinse skin or clothing immediately with plenty of water.
- If the battery liquid (dilute sulfuric acid) comes into contact with **eyes**, rinse eyes immediately with plenty of water and contact the nearest doctor or hospital to seek medical attention.

CAUTION

- **ALWAYS** disconnect the **NEGATIVE** battery terminal before performing service on the generator.
- **ALWAYS** keep battery cables in good working condition. Repair or replace all worn cables.

ENVIRONMENTAL SAFETY/DECOMMISSIONING

NOTICE

Decommissioning is a controlled process used to safely retire a piece of equipment that is no longer serviceable. If the equipment poses an unacceptable and unrepairable safety risk due to wear or damage or is no longer cost effective to maintain (beyond life-cycle reliability) and is to be decommissioned (demolition and dismantlement), be sure to follow the rules below:

- **NEVER** pour waste or oil directly onto the ground, down a drain, or into any water source.
- Contact your country's Department of Public Works or recycling agency in your area and arrange for proper disposal of any electrical components, waste or oil associated with this equipment.
- When the life cycle of this equipment is over, remove the battery and bring it to an appropriate facility for lead reclamation. Use safety precautions when handling batteries that contain sulfuric acid.
- When the life cycle of this equipment is over, it is recommended that the frame and all other metal parts be sent to a recycling center.



Metal recycling involves the collection of metal from discarded products and its transformation into raw materials to use in manufacturing a new product.

Recyclers and manufacturers alike promote the process of recycling metal. Using a metal recycling center promotes energy cost savings.

EMISSIONS INFORMATION

NOTICE

The diesel engine used in this equipment has been designed to reduce harmful levels of carbon monoxide (CO), hydrocarbons (HC), and nitrogen oxides (NOx) contained in diesel exhaust emissions.

This engine has been certified to meet US EPA evaporative emissions requirements in the installed configuration.

Attempting to modify or make adjustments to the engine emission system by unauthorized personnel without proper training could damage the equipment or create an unsafe condition.

Additionally, modifying the fuel system may adversely affect evaporative emissions, resulting in fines or other penalties.

Emission Control Label

The emission control label is an integral part of the emission system and is strictly controlled by regulations.

The label must remain with the engine for its entire life.

If a replacement emission label is needed, please contact your authorized engine distributor.

SPECIFICATIONS

Table 1. Generator Specifications		
Model	DCA45SSIU4F	
Type	Revolving field, self-ventilated, protected type synchronous generator	
Armature Connection	Star with Neutral	Zigzag
Phase	3Ø	1Ø
Standby Output	39.6 kW (49.5 kVA)	28.8 kW
Prime Output	36 kW (45 kVA)	26 kW
3Ø Voltage (L-L/L-N) Voltage Selector Switch at 3Ø 240/139	208Y/120, 220Y/127, 240Y/139	N/A
3Ø Voltage (L-L/L-N) Voltage Selector Switch at 3Ø 480/277	416Y/240, 440Y/254, 480Y/277	N/A
1Ø Voltage (L-L/L-N) Voltage Selector Switch at 1Ø 240/120	N/A	240/120
Power Factor	0.8	1.0
Frequency	60 Hz	
Speed	1,800 rpm	
Aux. AC Power	Single phase, 60 Hz	
Subtransient	0.102	
Transient	0.224	
Synchronous	2.043	
Zero Sequence Reactance	0.011	
Overload Protection	OCR/main circuit breaker	
Aux. Voltage/Output	120V/4.8 kW (2.4 kW × 2)	
Dry Weight	2,335 lb. (1,059 kg)	
Wet Weight	2,974 lb. (1,349 kg)	
Table 2. Engine Specifications		
Model	Isuzu 4LE2X	
Emission Regulation	EPA Tier 4 Final	
Type	4-Cycle Water-cooled, direct injection, turbo-charged, air-cooled EGR	
No. of Cylinders	4	
Bore × Stroke	3.35 in. × 3.78 in. (85 mm × 96 mm)	
Displacement	133 cu. in. (2.17 liters)	
Rated Output	59 hp at 1,800 rpm	
Starting	Electric	
Coolant Capacity (Radiator)	4.44 gal. (16.8 liters) ¹	
Lube Oil Capacity	3.2 gal. (12.2 liters) ²	
Lubricating Type Oil	API service class CJ-4 SAE or JASO DH-2	
Fuel Type	#2 diesel fuel (ultra low sulfur diesel fuel only)	
Fuel Leak Warning Capacity	21.1 gal. (80 liters)	
Fuel Tank Capacity	79.2 gal. (300 liters)	
Fuel Consumption	2.93 gal. (11.1 L)/hr. at full load	2.20 gal. (8.31 L)/hr. at 3/4 load
	1.60 gal. (6.04 L)/hr. at 1/2 load	1.04 gal. (3.92 L)/hr. at 1/4 load
Battery	27 (CCA 0°F 800A) × 1	

¹ Includes engine and radiator hoses

² Includes filters

DIMENSIONS

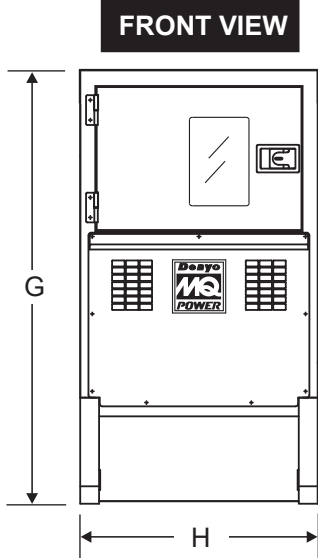
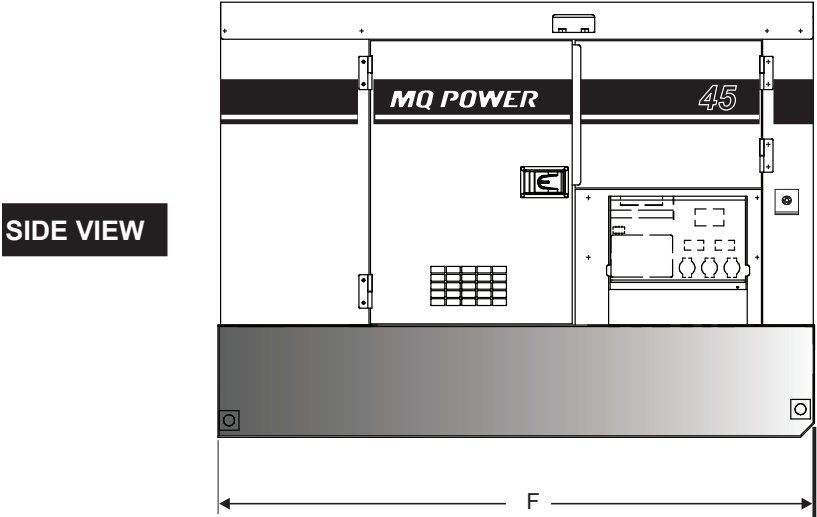
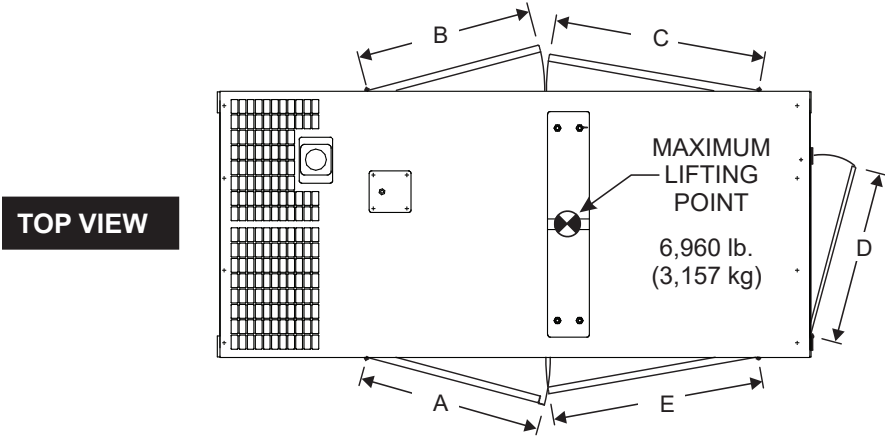

Figure 2. Dimensions

Table 3. Dimensions			
Reference Letter	Dimension in. (mm)	Reference Letter	Dimension in. (mm)
A	28.34 (720)	E	26.18 (665)
B	28.34 (720)	F	83.86 (2,130)
C	26.18 (665)	G	61.02 (1,550)
D	32.28 (820)	H	37.40 (950)

INSTALLATION

CONNECTING THE GROUND

Consult with local Electrical and Safety Codes for proper connection based on condition of use.

EXAMPLE of how to ground the unit if the condition of use requires such a device:

The ground terminal on the generator should always be used to connect the generator to a suitable ground when required.

Either copper or aluminum wire can be used as the ground cable. Cable size is determined by the maximum amperage of the generator. Reference Conductor Grounding Table, Article 250 of the NEC handbook.

Connect one end of the ground cable terminal to the generator ground point (Figure 3). Connect the other end of the ground cable to a suitable earth ground (ground rod).

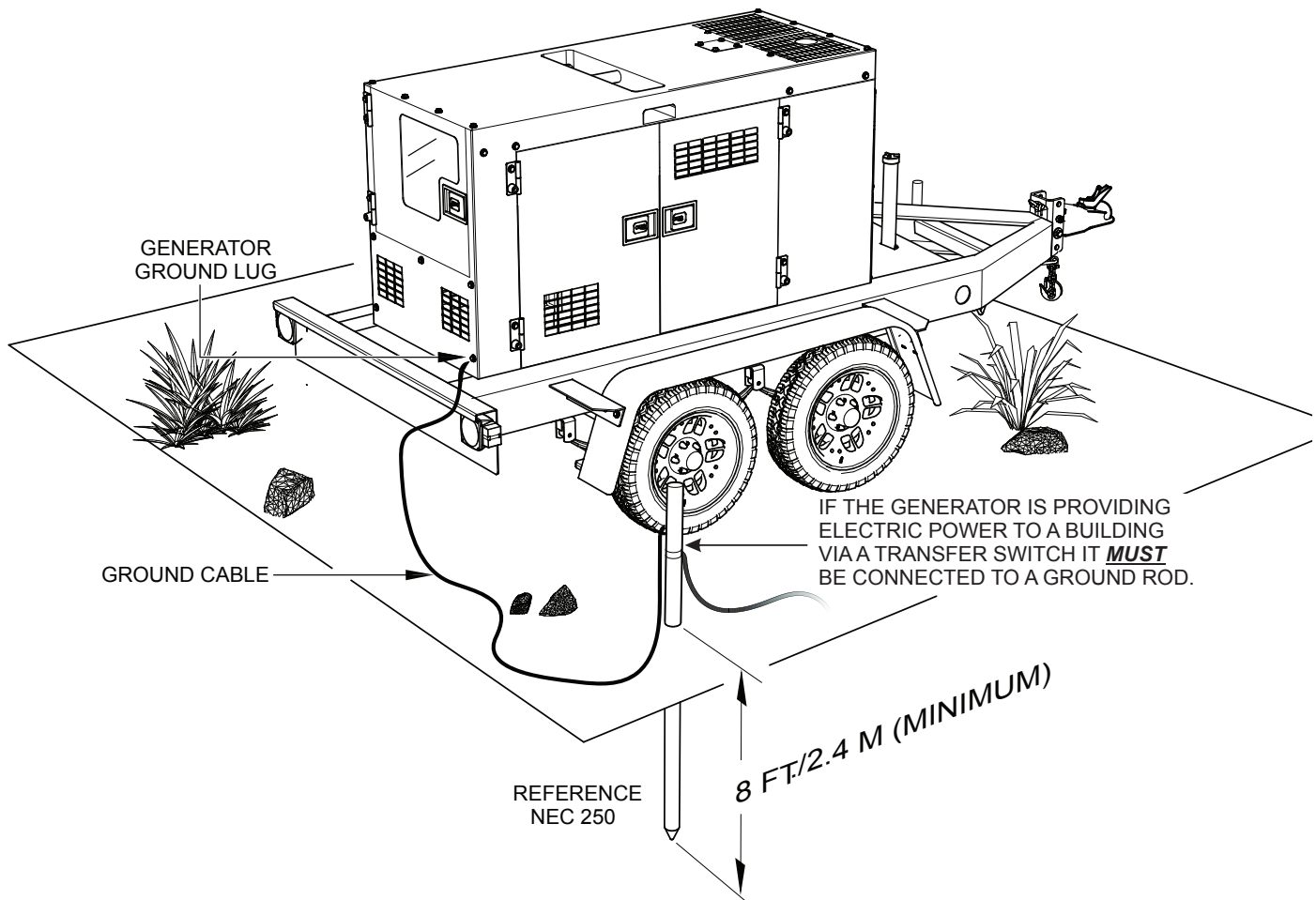

Figure 3. Typical Generator Grounding Application

NOTICE

Trailer-mounted generators are the sole responsibility of MQ Power.

OUTDOOR INSTALLATION

Install the generator in an area that is free of debris, bystanders, and overhead obstructions. Make sure the generator is on secure, level ground so that it cannot slide or shift around. Also install the generator in a manner so that the exhaust will not be discharged in the direction of nearby homes.

The installation site must be relatively free from moisture and dust. All electrical equipment should be protected from excessive moisture. Failure to do so will result in deterioration of the insulation and will result in short circuits and grounding.

Foreign materials such as dust, sand, lint and abrasive materials have a tendency to cause excessive wear to engine and alternator parts.

CAUTION

Pay close attention to ventilation when operating the generator inside tunnels and caves. The engine exhaust contains noxious elements. Engine exhaust must be routed to a ventilated area.

INDOOR INSTALLATION

Exhaust gases from diesel engines are extremely poisonous. Whenever an engine is installed indoors the exhaust fumes must be vented to the outside. The engine should be installed at least two feet from any outside wall. Using an exhaust pipe which is too long or too small can cause excessive back pressure which will cause the engine to heat excessively and possibly burn the valves.

MOUNTING

The generator must be mounted on a solid foundation (such as concrete) and set firmly on the foundation to isolate vibration of the generator when it is running. The generator must be mounted at least 6 inches above the floor or grade level as referenced in the National Fire Protection Association (NFPA 110, Chapter 7, section 7.4) handbook.

DO NOT remove the metal skids on the bottom of the generator. They are to resist damage to the bottom of the generator and to maintain alignment.

GENERATOR GROUNDING

NOTICE

The Occupational Safety and Health Administration (OSHA) and the National Electrical Code (NEC) recommend that if the generator is providing electrical power to a structure (home, office shop, trailer or similar), it **must** be connected to a grounding electrode system, such as a driven ground rod (Figure 3).

If applicable, to guard against electrical shock and possible damage to the equipment, it is important to provide a good **EARTH** ground (Figure 3).

NOTICE

ALWAYS check with State, Province, District and Municipalities for electrical grounding requirements before using the generator.

Article 250 (Grounding) of the NEC handbook provides guidelines for proper grounding and specifies that the cable ground shall be connected to the grounding system of the building as close to the point of cable entry as practical.

1. Use one of the following wire types to connect the generator to earth ground.
 - a. Copper
 - b. Aluminum

NOTICE

Reference Conductor Grounding Table, Article 250 of the NEC handbook for proper conductor wire size. Wire size is determined by the maximum amperage of the generator.

2. When grounding of the generator (Figure 3) is required, connect one end the ground cable to the ground lug on the generator. Connect the other end of the ground cable to the ground rod (earth ground).
3. NEC Article 250 specifies that the earth ground rod should be buried a minimum of 8 feet into the ground.

NOTICE

When connecting the generator to any building's electrical system **ALWAYS** consult with a licensed electrician.

GENERAL INFORMATION

GENERATOR

This generator (Figure 4) is designed as a high-quality, portable (requires a trailer for transport) power source for telecom sites, lighting facilities, power tools, submersible pumps and other industrial and construction machinery.

OPERATING PANEL

The “Operating Panel” is provided with the following:

- ECU Controller with Gauge Unit Assembly
 - Oil Pressure Gauge
 - Water Temperature Gauge
 - Charging Voltmeter
 - Fuel Gauge
 - Tachometer
- Panel Light/Panel Light Switch
- Pre-Heat Lamp
- Warning Lamp (Diagnostic)
- Hour Meter
- Engine Speed Switch
- Auto Start/Stop Switch
- Fuel Leak Detected Alarm Lamp

CONTROL PANEL

The “Control Panel” is provided with the following:

- Frequency Meter (Hz)
- AC Ammeter (Amps)
- AC Voltmeter (Volts)
- Ammeter Change-Over Switch
- Voltmeter Change-Over Switch
- Voltage Regulator
- 3-Pole, 110-amp Main Circuit Breaker
- “Control Box” (located behind Control Panel)
 - Automatic Voltage Regulator
 - Current Transformer
 - Overcurrent Relay
 - Starter Relay

OUTPUT TERMINAL PANEL

The “Output Terminal Panel” is provided with the following:

- Three 120/240V Output Receptacles (CS-6369), 50A
- Three Auxiliary Circuit Breakers, 50A
- Two 120V Output Receptacles (GFCI), 20A
- Two GFCI Circuit Breakers, 20A
- Five Output Terminal Lugs (3Ø power)
- Battery Charger (Option)
- Jacket Water Heater (Option)
- Low Coolant Switch (Option)

OPEN-DELTA EXCITATION SYSTEM

Each generator is equipped with the state-of-the-art “Open-Delta” excitation system. The open-delta system consists of an electrically independent winding wound among stationary windings of the AC output section.

There are four connections of the open delta—A, B, C and D. During steady-state loads, the power from the voltage regulator is supplied from the parallel connections of A to B, A to D, and C to D. These three phases of the voltage input to the voltage regulator are then rectified and are the excitation current for the exciter section.

When a heavy load such as a motor starting or a short circuit occurs, the automatic voltage regulator (AVR) switches the configuration of the open delta to the series connection of B to C. This has the effect of adding the voltages of each phase to provide higher excitation to the exciter section and thus better voltage response during the application of heavy loads.

The connections of the AVR to the AC output windings are for sensing only. No power is required from these windings. The open-delta design provides virtually unlimited excitation current, offering maximum motor starting capabilities. The excitation does not have a “fixed ceiling” and responds according to the demands of the required load.

ENGINE

This generator is powered by a 4-cylinder, 4-cycle, water-cooled, direct injection, turbocharged, EGR, DOC, Isuzu 4LE2X diesel engine. This engine is designed to meet every performance requirement for the generator. Reference Table 2 for engine specifications.

In keeping with MQ Power’s policy of constantly improving its products, the specifications quoted herein are subject to change without prior notice.

MICROPROCESSOR CONTROL SYSTEM

The microprocessor controls the RPMs of the engine. When the engine demand increases or decreases, the microprocessor system regulates the frequency variation to $\pm 0.25\%$.

EXTENSION CABLES

When electric power is to be provided to various tools or loads at some distance from the generator, extension cords are normally used. Cables should be sized to allow for distance in length and amperage so that the voltage drop between the generator and point of use (load) is held to a minimum. Use the cable selection chart (Table 6) as a guide for selecting the proper extension cable size.

MAJOR COMPONENTS

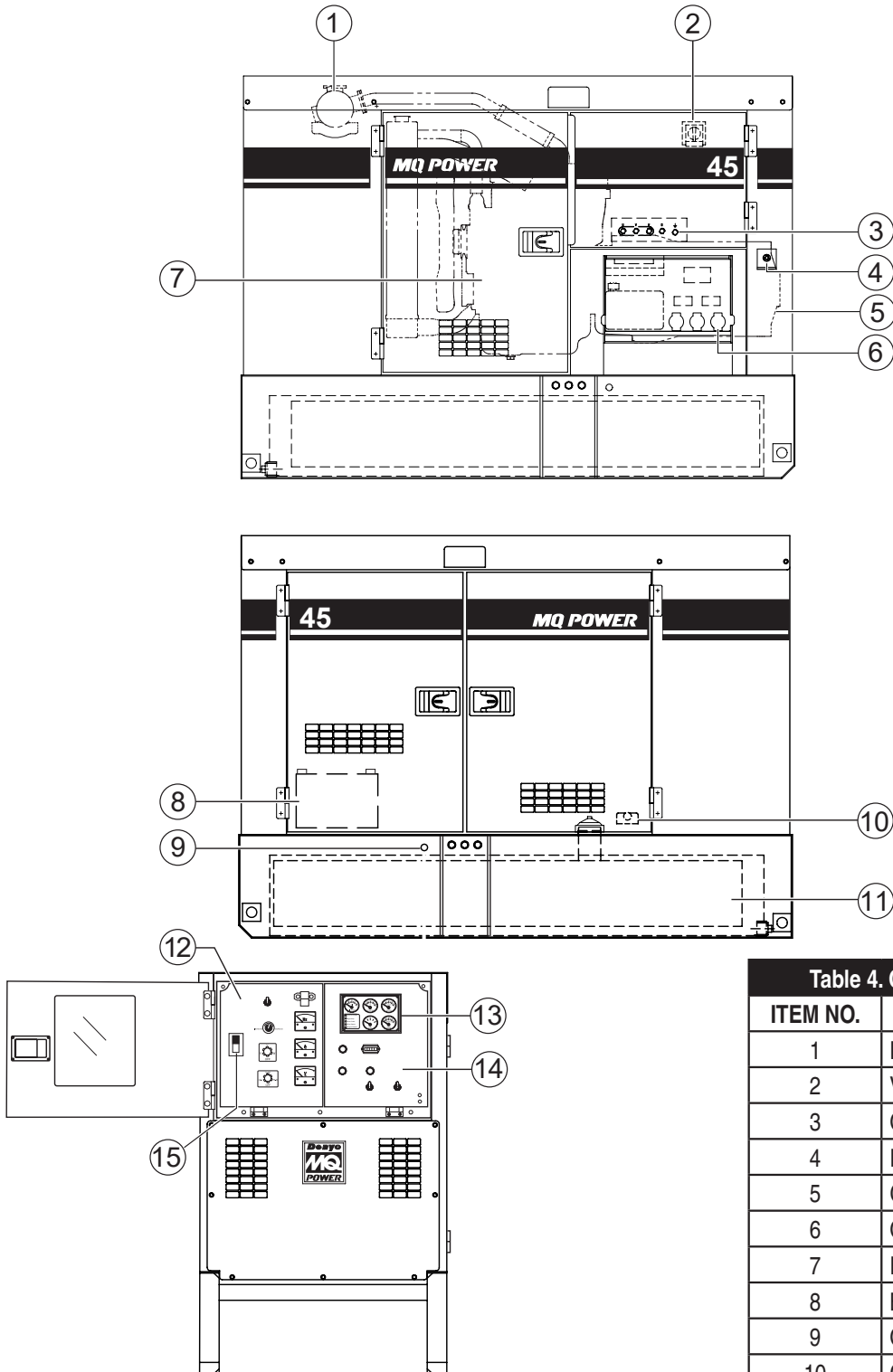

Figure 4. Generator Major Components

Table 4. Generator Major Components	
ITEM NO.	DESCRIPTION
1	DOC Assembly
2	Voltage Selector Switch Assembly
3	Output Terminal Assembly
4	Emergency Stop Switch
5	Generator Assembly
6	Output Receptacles Assembly
7	Engine Assembly
8	Battery Assembly
9	Oil Drain
10	Coolant Drain
11	Fuel Tank Assembly
12	Generator Control Panel Assembly
13	Controller/Gauge Unit Assembly
14	Engine Control Panel Assembly
15	Circuit Breaker

ENGINE/GENERATOR CONTROL PANEL

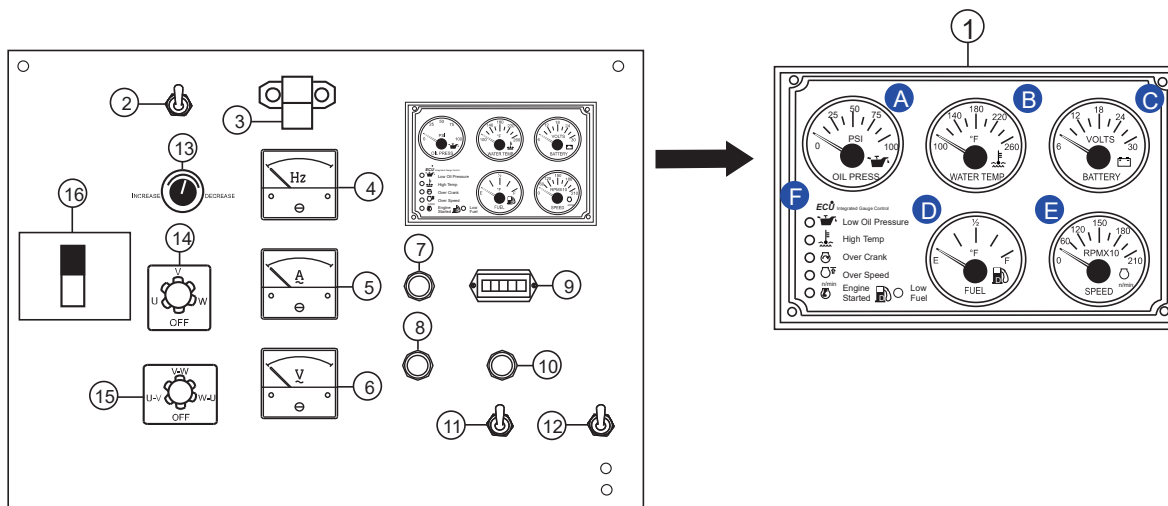

Figure 5. Engine/Generator Control Panel

The definitions below describe the controls and functions of the Engine/Generator Control Panel (Figure 5).

1. **ECU Controller with Gauge Unit Assembly** — This assembly houses the various engine monitoring gauges. These gauges indicate: oil pressure, water temperature, charging voltmeter, fuel, and engine speed RPM (tachometer).

A. **Oil Pressure Gauge** — During normal operation this gauge should read approximately 50 psi (345 kPa). When starting the generator the oil pressure may read a little higher, but after the engine warms up the oil pressure should return to the correct pressure range.

B. **Water Temperature Gauge** — During normal operation this gauge should indicate approximately 180°F (82°C).

C. **Charging Voltmeter Gauge** — During normal operation this gauge should indicate minimum 14 VDC.

D. **Fuel Gauge** — Indicates amount of diesel fuel available.

E. **Tachometer** — Indicates engine speed in RPM for 60 Hz operation. This meter should indicate 1,800 rpm when the rated load is applied.

F. Warning LEDs

- **Low Oil Pressure LED** — This LED will light when the engine oil pressure drops to 14.2 psi. This condition will cause the engine to shut down.
- **High Temperature LED** — This LED will light when the coolant temperature has reached 212°F (100°C). This condition will cause the engine to shut down.
- **Over Crank LED** — This LED will light when the engine has attempted to start 3 times and failed. The interval between the 3 start cycles is approximately 10 seconds.
- **Over Speed LED** — This LED will light when the engine is running at an unsafe speed. This condition will cause the engine to shut down.
- **Engine Started LED** — This LED will light when the engine has started and is operating correctly.
- **Low Fuel LED** — When ON (lit) indicates that 20% fuel remains. Engine will shutdown with 5% fuel remaining.

2. **Panel Light Switch** — When activated will turn on the control panel light.

3. **Panel Light** — For operation at night, the panel light illuminates the control panel for ease of reading meters and gauges. Make sure the panel light switch is in the **OFF** position when the light is not in use.

ENGINE/GENERATOR CONTROL PANEL

4. **Frequency Meter** — Indicates the output frequency in hertz (Hz). Normally 60 Hz.
5. **AC Ammeter** — Indicates the amount of current the load is drawing from the generator per leg selected by the ammeter phase-selector switch.
6. **AC Voltmeter** — Indicates the output voltage present at the **U,V, and W Output Terminal Lugs**.
7. **Fuel Leak Detected Alarm Lamp** — This lamp when **ON** indicates that fluids in the containment area have reached a high level.
8. **Warning Lamp** — This lamp turns **ON** when an engine fault/failure has occurred. Reference the **Troubleshooting Diagnostic Lamp** section in this manual for fault code details.
9. **Hour Meter** — Indicates the operational hours of the generator.
10. **Pre-Heat Lamp** — When the Auto Start/Stop Switch is placed in the manual position, this lamp will illuminate to indicate preheating of the engine glow plugs. When the lamp turns off, this indicates that the preheat cycle is complete and the engine can be started.
11. **Auto Start-Stop Switch** — This switch selects either manual or automatic operation. Center position is **OFF** (reset).
12. **Engine Speed Switch** — This switch controls the speed of the engine, low or high.
13. **Voltage Regulator Control** — Allows $\pm 15\%$ manual adjustment of the generator's output voltage.
14. **Ammeter Change-Over Switch** — This switch allows the AC ammeter to indicate the current flowing to the load connected to any phase of the output terminals, or to be switched off. This switch does not affect the generator output in any fashion, it is for current reading only.
15. **Voltmeter Change-Over Switch** — This switch allows the AC voltmeter to indicate phase-to-phase voltage between any two phases of the output terminals or to be switched off.
16. **Main Circuit Breaker** — This three-pole, 110-amp main breaker is provided to protect the **U,V, and W Output Terminal Lugs** from overload.

OUTPUT TERMINAL PANEL FAMILIARIZATION

OUTPUT TERMINAL PANEL

The Output Terminal Panel (Figure 6) shown below is located on the right-hand side (left from the control panel) of the generator. Lift up on the cover to gain access to receptacles and terminal lugs.

NOTICE

Terminal legs "O" and "Ground" are considered bonded grounds.

OUTPUT TERMINAL FAMILIARIZATION

The "Output Terminal Panel" (Figure 6) is provided with the following:

- Three 240/120V Output Receptacles @ 50 amps
- Three Aux. Circuit Breakers @ 50 amps
- Two 120V GFCI receptacles @ 20 amps
- Two GFCI Circuit Breakers @ 20 amps
- Five Output Terminal Lugs (U, V, W, O, Ground)

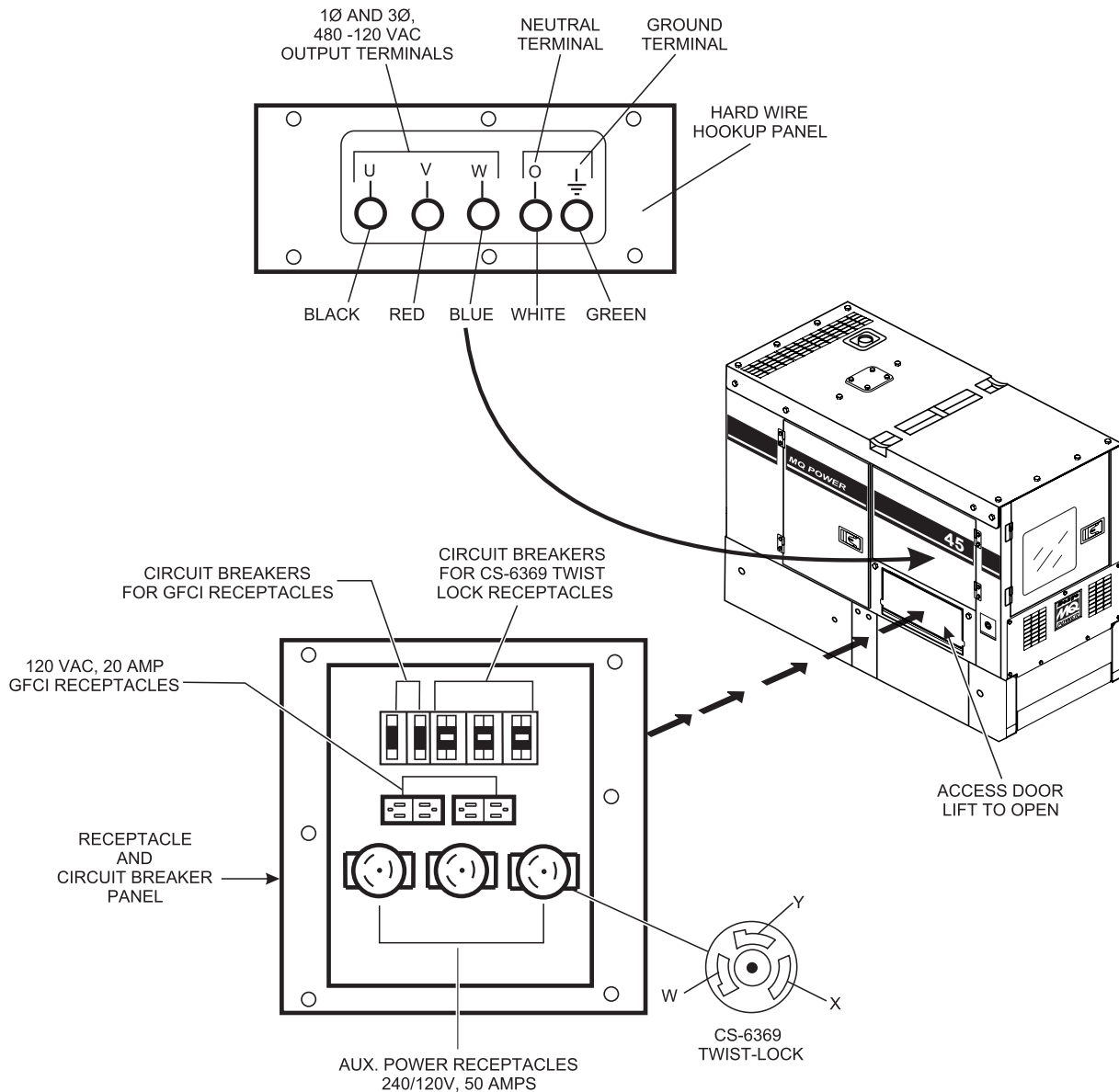

Figure 6. Output Terminal Panel

OUTPUT TERMINAL PANEL FAMILIARIZATION

120 VAC GFCI Receptacles

NOTICE

It is recommended that the GFCI receptacles be tested when the generator is initially uncrated. The receptacles should then be tested daily at startup.

There are two 120 VAC, 20-amp GFCI (Duplex NEMA 5-20R) receptacles provided on the output terminal panel. These receptacles can be accessed in any **voltage selector switch** position. Each receptacle is protected by a 20-amp circuit breaker. These breakers are located directly above the GFCI receptacles. Remember the load output (current) of both GFCI receptacles is dependent on the load requirements of the U, V, and W output terminal lugs.

Pressing the **reset** button resets the GFCI receptacle after being tripped. Pressing the **test button** (see Figure 7) in the center of the receptacle will check the GFCI function. Both receptacles should be tested at least once a month. Reference the maintenance section in this manual for further testing of the GFCI receptacle.

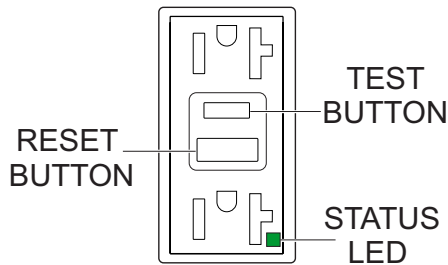

Figure 7. GFCI Receptacle

Twist-Lock Dual-Voltage 240/120 VAC Receptacles

There are three 240/120V, 50-amp, auxiliary twist-lock (CS-6369) receptacles (Figure 8) provided on the output terminal panel. These receptacles can **only** be accessed when the voltage selector switch is placed in the **single-phase 240/120V** position.

CS6369 TWIST-LOCK RECEPTACLES

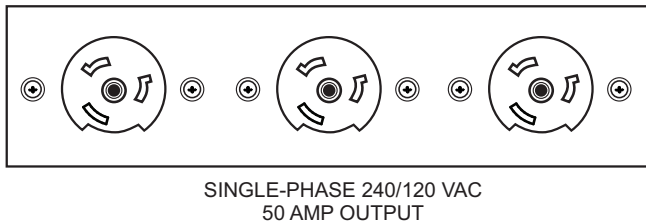

Figure 8. 240/120V Twist-Lock Auxiliary Receptacles

Each auxiliary receptacle is protected by a 50-amp circuit breaker. These breakers are located directly above the GFCI receptacles. Remember the load output (current) on both receptacles is dependent on the load requirements of the **output terminal lugs**.

Voltage Regulator

NOTICE

The voltage regulator (VR) allows the user to increase or decrease the selected voltage.

Turn the **voltage regulator control knob** (Figure 9) on the control panel to obtain the desired voltage. Turning the knob clockwise will **increase** the voltage, turning the knob counterclockwise will **decrease** the voltage.



Figure 9. Voltage Regulator Control Knob

Removing the Plastic Face Plate (Hard Wire Hookup Panel)

The **Output Terminal Lugs** are protected by a plastic face plate cover (Figure 10). Unscrew the securing bolts and lift the plastic terminal cover to gain access to the terminal enclosure.

After the load wires have been securely attached to the terminal lugs, reinstall the plastic face plate.

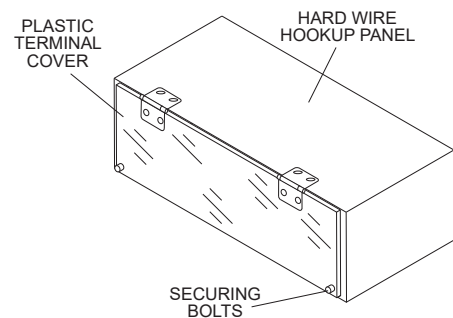

Figure 10. Plastic Face Plate (Output Terminal Lugs)

OUTPUT TERMINAL PANEL FAMILIARIZATION

Connecting Loads

Loads can be connected to the generator by various methods, output terminal lugs, camlocks or the convenience receptacles (Figure 11). Make sure to read the operation manual before attempting to connect a load to the generator.

To protect the output terminals from overload, a 3-pole, 110-amp, **main** circuit breaker is provided. Make sure to switch **ALL** circuit breakers to the **OFF** position prior to starting the engine.

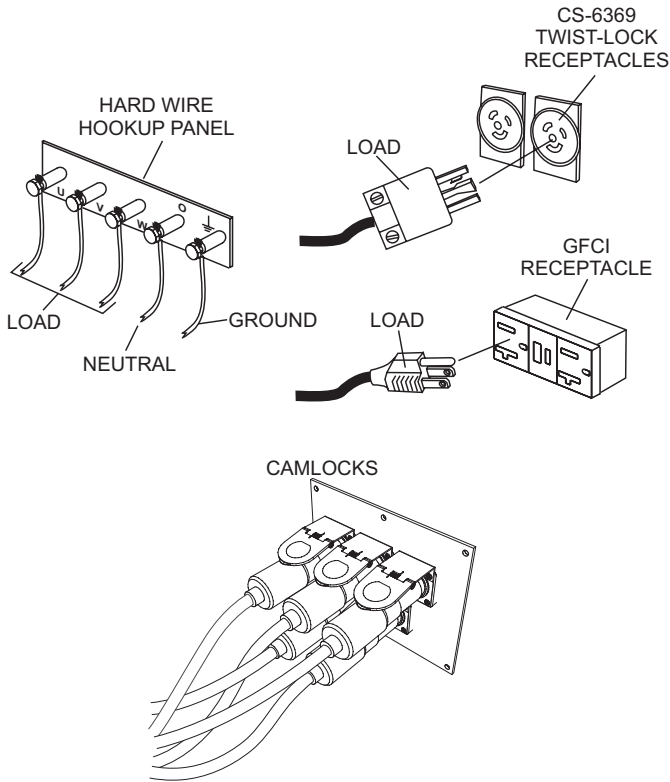

Figure 11. Connecting Loads

Overcurrent Relay

An **overcurrent relay** (Figure 12) is connected to the main circuit breaker. In the event of an overload, both the circuit breaker and the overcurrent relay may trip. If the circuit breaker can not be reset, the **reset button** on the overcurrent relay must be pressed. The overcurrent relay is located inside the control box.

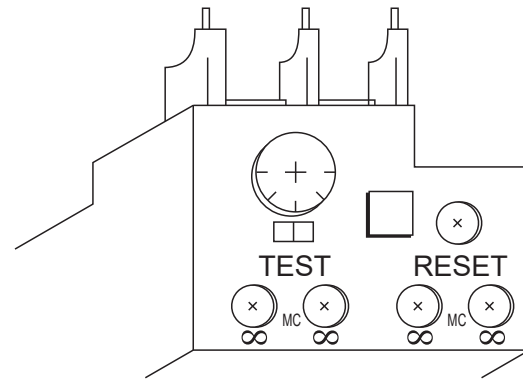

Figure 12. Overcurrent Relay

NOTICE

Remember the **overcurrent relay** monitors the current flowing from the **U,V, and W Output Terminal Lugs** to the load.

In the event of a short circuit or overcurrent condition, it will automatically trip the 110-amp main breaker.

To restore power to the **Output Terminal Panel**, press the reset button on the overcurrent relay and place the **main** circuit breaker in the **closed** position (**ON**).

LOAD APPLICATION

SINGLE-PHASE LOAD

Always be sure to check the nameplate on the generator and equipment to ensure the wattage, amperage, frequency, and voltage requirements are satisfactorily supplied by the generator for operating the equipment.

Generally, the wattage listed on the nameplate of the equipment is its rated output. Equipment may require 130–150% more wattage than the rating on the nameplate, as the wattage is influenced by the efficiency, power factor and starting system of the equipment.

NOTICE

If wattage is not given on the equipment's nameplate, approximate wattage may be determined by multiplying nameplate voltage by the nameplate amperage.

$$\text{WATTS} = \text{VOLTAGE} \times \text{AMPERAGE}$$

The power factor of this generator is 0.8. See Table 5 below when connecting loads.

Table 5. Power Factor By Load

Type of Load	Power Factor
Single-phase induction motors	0.4–0.75
Electric heaters, incandescent lamps	1.0
Fluorescent lamps, mercury lamps	0.4–0.9
Electronic devices, communication equipment	1.0
Common power tools	0.8

Table 6. Cable Selection (60 Hz, Single-Phase Operation)

Current in Amperes	Load in Watts		Maximum Allowable Cable Length			
	At 120 Volts	At 240 Volts	#10 Wire	#12 Wire	#14 Wire	#16 Wire
2.5	300	600	1,000 ft.	600 ft.	375 ft.	250 ft.
5	600	1,200	500 ft.	300 ft.	200 ft.	125 ft.
7.5	900	1,800	350 ft.	200 ft.	125 ft.	100 ft.
10	1,200	2,400	250 ft.	150 ft.	100 ft.	
15	1,800	3,600	150 ft.	100 ft.	65 ft.	
20	2,400	4,800	125 ft.	75 ft.	50 ft.	

CAUTION: Equipment damage can result from low voltage.

NOTICE

Cable selection table is a general guideline. **ALWAYS** consult local and national electrical codes when sizing cables.

THREE-PHASE LOAD

When calculating the power requirements for 3-phase power use the following equation:

$$\text{KVA} = \frac{\text{VOLTAGE} \times \text{AMPERAGE} \times 1.732}{1000}$$

NOTICE

If 3Ø load (kVA) is not given on the equipment nameplate, approximate 3Ø load may be determined by multiplying voltage by amperage by 1.732.

NOTICE

Motors and motor-driven equipment draw much greater current for starting than during operation.

An inadequately sized connecting cable which cannot carry the required load can cause a voltage drop which can burn out the appliance or tool and overheat the cable. See Table 6.

- When connecting a resistance load such as an incandescent lamp or electric heater, a capacity of up to the generating set's rated output (kW) can be used.
- When connecting a fluorescent or mercury lamp, a capacity of up to the generating set's rated output (kW) multiplied by 0.6 can be used.
- When connecting an electric drill or other power tools, pay close attention to the required starting current capacity.

When connecting ordinary power tools, a capacity of up to the generating set's rated output (kW) multiplied by 0.8 can be used.

DANGER

Before connecting this generator to any building's electrical system, a **licensed electrician** must install an **isolation (transfer) switch**. Serious damage to the building's electrical system may occur without this transfer switch.

GENERATOR OUTPUTS

GENERATOR OUTPUT VOLTAGES

A wide range of voltages are available to supply voltage for many different applications. Voltages are selected by using the **voltage selector** switch (Figure 13). To obtain some of the voltages as listed in Table 7 (see below) will require a fine adjustment using the **voltage regulator (VR) control knob** located on the control panel.

Voltage Selector Switch

The voltage selector switch (Figure 13) is located above the output terminal panel's Hard Wire Hook-Up Panel. It has been provided for ease of voltage selection..

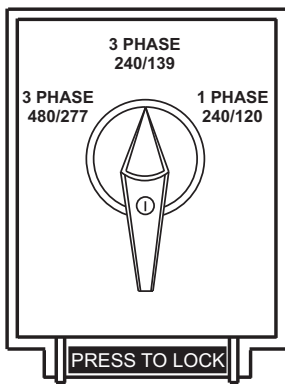

Figure 13. Voltage Selector Switch

CAUTION

NEVER change the position of the **voltage selector switch** while the engine is running. **ALWAYS** place the circuit breaker in the **OFF** position before selecting voltage.

Table 7. Voltages Available						
UVWO Output Terminal Lugs	Voltage Selector Switch 3-Phase 240/139V Position			Voltage Selector Switch 3-Phase 480/270V Position		
	3Ø Line-Line	208V	220V	240V	416V	440V
1Ø Line-Neutral	120V	127V	139V	240V	254V	277V
Voltage Selector Switch Single-Phase 240/120V Position						
1Ø Line-Neutral/Line-Line	120V Line-Neutral	N/A	N/A	240V Line-Line	N/A	N/A

Maximum Amps

Table 8 shows the **maximum** amps the generator can provide. **DO NOT** exceed the maximum amps as listed.

Table 8. Generator Maximum Amps	
Rated Voltage	Maximum Amps
1Ø 120 volts	108 amps × 2 (zigzag)
1Ø 240 volts	108 amps (zigzag)
3Ø 240 volts	108 amps
3Ø 480 volts	54 amps
Main Line Circuit Breaker Rating	110 amps

GFCI Receptacle Load Capability

The load capability of the GFCI receptacles is directly related to the voltage being supplied at either the output terminals or the three twist-lock auxiliary receptacles.

Table 9 and Table 10 show what amount of current is available at the GFCI receptacles when the output terminals and twist-lock receptacles are in use. Be careful that your load does not exceed the available current capability at the receptacles.

Table 9. 1Ø GFCI Receptacle Load Capacity	
kW in Use Twist Lock (CS6369)	Available Load Current (Amps)
1Ø 240/120V	GFCI Duplex 5-20R 120V
26	0
24.8	5 amps/receptacle
23.6	10 amps/receptacle
22.4	15 amps/receptacle
21.2	20 amps/receptacle

Table 10. 3Ø Generator Maximum Amps	
kVA in Use (UVWO Terminals)	Available Load Current (Amps)
3Ø 240/480V	GFCI Duplex 5-20R 120V
45	0 amps/receptacle
40.9	5 amps/receptacle
36.7	10 amps/receptacle
32.6	15 amps/receptacle
28.4	20 amps/receptacle

GENERATOR OUTPUTS/GAUGE READING

HOW TO READ THE AC AMMETER AND AC VOLTMETER GAUGES

The AC ammeter and AC voltmeter gauges are controlled by the AC ammeter and AC voltmeter change-over switches.

Both of these switches are located on the control panel and **DO NOT** affect the generator output. They are provided to help observe how much power is being produced at the UVWO terminal lugs.

Before taking a reading from either gauge, set the **Voltage Selector Switch** (Figure 14) to the position which produces the required voltage. For example, for 3Ø 240V, choose the center 3Ø 240/139V position on the voltage selector switch.

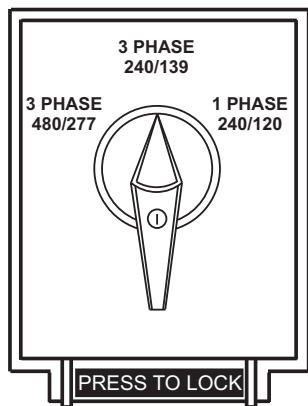

Figure 14. Voltage Selector Switch- 240/3Ø Position

AC Voltmeter Gauge Reading

Place the **AC Voltmeter Change-Over Switch** (Figure 15) in the W-U position and observe the phase to phase voltage reading between the W and U terminals as indicated on the **AC Voltmeter Gauge** (Figure 16).

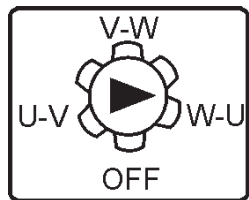

Figure 15. AC Voltmeter Change-Over Switch

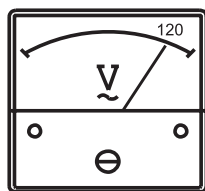

Figure 16. AC Voltmeter Gauge (Volt Reading on W-U Lug)

AC Ammeter Gauge Reading

Place the **AC Ammeter Change-Over Switch** (Figure 17) in the U position and observe the current reading (load drain) on the U terminal as indicated on the **AC Ammeter Gauge** (Figure 18). This process can be repeated for terminals V and W.

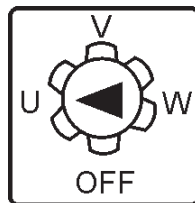

Figure 17. AC Ammeter Change-Over Switch

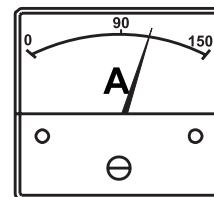

Figure 18. AC Ammeter (Amp Reading on U Lug)

NOTICE

The **ammeter** gauge will only show a reading when the **Output Terminal Lugs** are connected to a load and in use.

OUTPUT TERMINAL PANEL CONNECTIONS

UVWO TERMINAL OUTPUT VOLTAGES

Various output voltages can be obtained using the UVWO output terminal lugs. The voltages at the terminals are dependent on the position of the **Voltage Selector Switch** and the adjustment of the **Voltage Regulator Control Knob**.

Remember the voltage selector switch determines the **range** of the output voltage. The voltage regulator (VR) allows the user to increase or decrease the selected voltage.

3Ø-240V UVWO Terminal Output Voltages

1. Place the voltage selector switch in the 3Ø 240/139 position as shown in Figure 19.

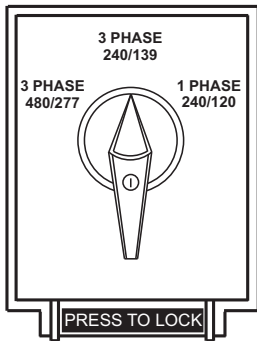

Figure 19. Voltage Selector Switch 3Ø-240/139V Position

2. Connect the load wires to the UVWO terminals as shown in Figure 20.

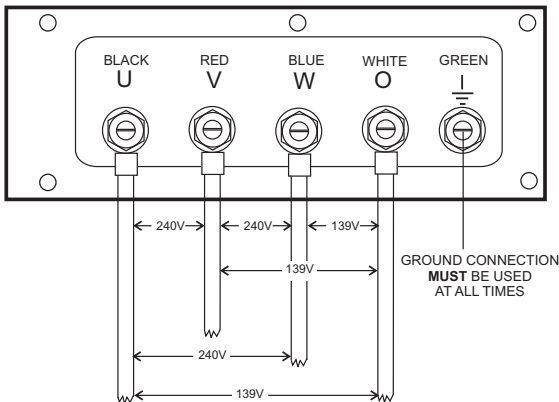

Figure 20. UVWO Terminal Lugs

3. Turn the voltage regulator knob (Figure 21) clockwise to increase voltage output, turn counterclockwise to decrease voltage output. Use the voltage regulator adjustment knob whenever fine tuning of the output voltage is required.



Figure 21. Voltage Regulator Knob

3Ø-208V/1Ø-120V UVWO Terminal Output Voltages

1. Place the voltage selector switch in the 3Ø 240/139 position as shown in Figure 19.
2. Connect the load wires to the UVWO terminals as shown in Figure 22.

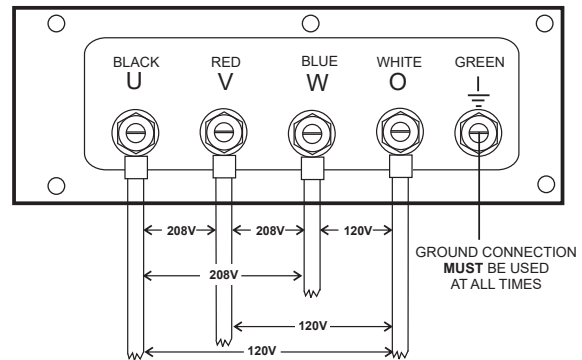

Figure 22. UVWO Terminal Lugs 3Ø-208V/1Ø-120V Connections

NOTICE

To achieve a 3Ø 208V output the voltage selector switch must be in the 3Ø-240/139 position and the voltage regulator must be adjusted to 208V.

OUTPUT TERMINAL PANEL CONNECTIONS

3Ø-480/277V UVWO Terminal Output Voltages

1. Place the voltage selector switch in the 3Ø 480/277 position as shown in Figure 23.

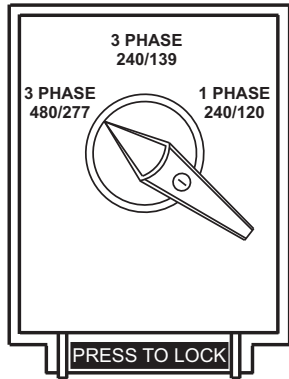

**Figure 23. Voltage Selector Switch
3Ø-480/277V Position**

2. Connect the load wires to the UVWO terminals as shown in Figure 24.

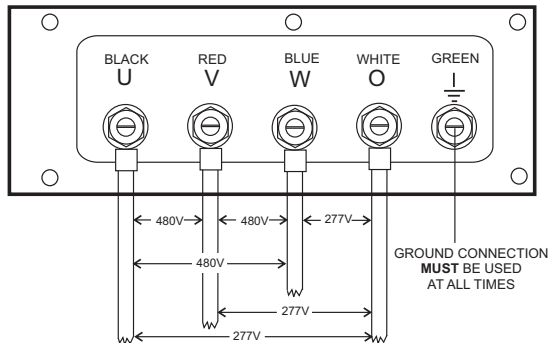

**Figure 24. UVWO Terminal Lugs 3Ø-480V
Connections**

NOTICE

ALWAYS make sure that the connections to the UVWO terminals are **secure** and **tight**. The possibility of arcing exists, that could cause a fire.

1Ø-240/120V UVWO Terminal Output Voltages

1. Place the voltage selector switch in the 1Ø 240/120 position as shown in Figure 25.

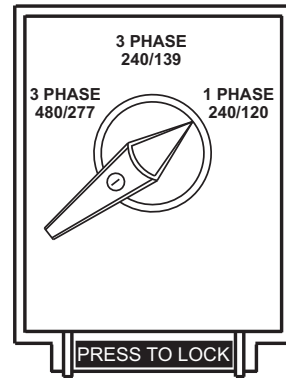

**Figure 25. Voltage Selector Switch
1Ø-240/120V Position**

2. Connect the load wires to the UVWO terminals as shown in Figure 26.

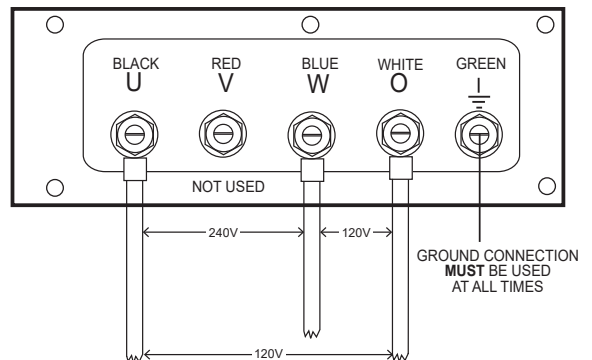

**Figure 26. UVWO Terminal Lugs
1Ø-240/120V Connection**

3. Turn the voltage regulator knob (Figure 21) clockwise to increase voltage output, turn counterclockwise to decrease voltage output. Use the voltage regulator adjustment knob whenever fine tuning of the output voltage is required.

ENGINE OIL CHECK

NOTICE

This **Isuzu** engine is equipped with a low oil shutdown capability. A built-in sensor will automatically turn off the engine should the oil level fall below a safe operating condition. Make sure the generator is placed on level ground. Placing the generator on level ground will ensure that the low oil sensor functions properly.

1. To check the engine oil level, place the generator on secure, level ground with the engine stopped.
2. Remove the dipstick from its holder (Figure 27) and wipe it clean.

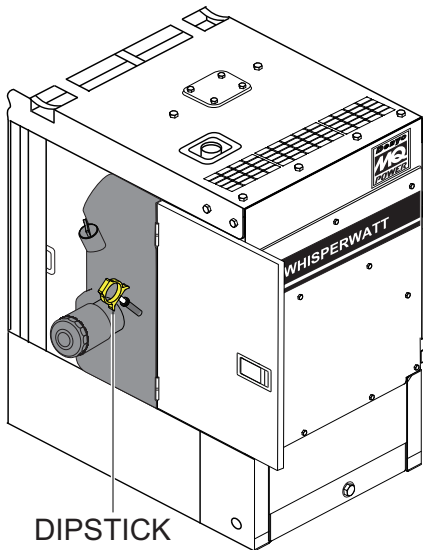

Figure 27. Engine Oil Dipstick

3. Reinsert the dipstick, then remove the dipstick from its holder. Check the oil level shown on the dipstick (Figure 28).

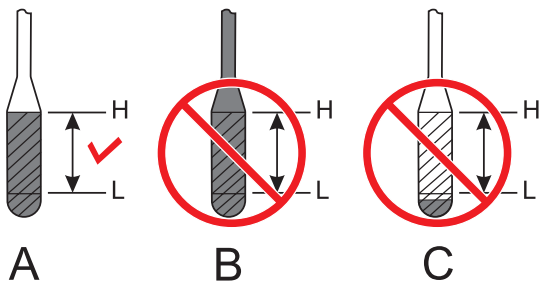

Figure 28. Engine Oil Dipstick

4. Verify that the engine oil level is maintained between the **H** and **L** markings on the dipstick as referenced in Figure 28A.

5. If the engine oil level is low (Figure 28C), remove the oil filler cap (Figure 29) and fill to a safe operating level (max) as indicated by the dipstick (Figure 28A).

NOTICE

When adding engine oil **DO NOT** overfill (Figure 28B).

6. Fill with recommended type oil as listed in Table 11. Maximum oil capacity is 12.8 quarts (12.2 liters).

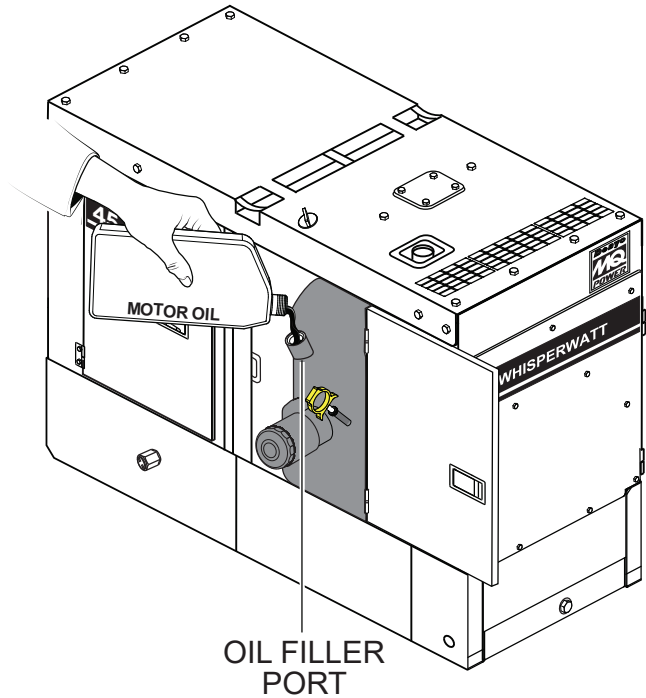

Figure 29. Engine Oil Filler Port

When checking the engine oil, be sure to check if the oil is clean. If the oil is not clean, drain the oil as referenced in the maintenance section of this manual.

Table 11. Recommended Motor Oil

SAE Grade	Temperature Range (°F)	Temperature Range (°C)
SAE 30	40 - 100	10 - 38
SAE 20, 20W	0 - 100	-20 - 38
SAE 10W	-20 - 100	-30 - 38
SAE 10W-30	-20 - 100	-30 - 38
SAE 40	40 - 100	10 - 38
SAE 5W-40, 20W-40	-20 - 100	-30 - 38
SAE 5W-20	-20 - 100	-30 - 38

FUEL CHECK

DANGER



Fuel spillage on a **hot** engine can cause a **fire** or **explosion**. If fuel spillage occurs, wipe up the spilled fuel completely to prevent fire hazards. **NEVER** smoke around or near the generator. **ALWAYS** shut down the engine prior to cleaning up any spilled fuel.

Refilling the Fuel System

NOTICE

DO NOT refuel while the engine is running.

CAUTION

ONLY properly trained personnel who have read and understand this section should refill the fuel tank system.

ALWAYS fill the fuel tank (Figure 30) with clean, fresh #2 diesel fuel. **DO NOT** fill the fuel tank beyond its capacity.

Pay attention to the fuel tank capacity when replenishing fuel. The fuel tank cap must be closed tightly after filling. Handle fuel in a safety container. If the container does not have a spout, use a funnel. Wipe up any spilled fuel immediately.

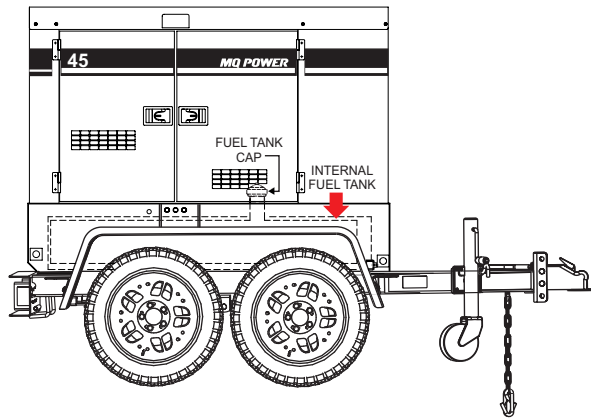

Figure 30. Fuel Tank

REFUELING PROCEDURE

WARNING



Diesel fuel and its vapors are dangerous to your health and the surrounding environment. Avoid skin contact and/or inhaling fumes.

1. **Level Tanks** — Make sure fuel cells are level with the ground. Failure to do so will cause fuel to spill from the tank before reaching full capacity (Figure 31).

CAUTION

ALWAYS place the trailer on firm, level ground before refueling to prevent spilling and maximize the amount of fuel that can be pumped into the tank.

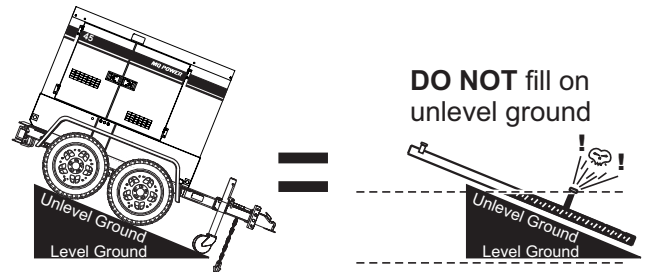

Figure 31. Only Fill on Level Ground

NOTICE

ONLY use #2 diesel fuel when refueling.

2. Open cabinet doors on the “right side” of the generator (from the generator control panel position). Remove the fuel cap and fill the tank (Figure 32).

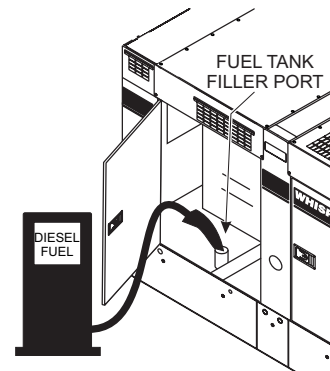

Figure 32. Fueling the Generator

- NEVER overfill the fuel tank** — It is important to read the fuel gauge when filling the trailer fuel tank. **DO NOT** wait for fuel to rise in the filler neck (Figure 33).

FUEL GAUGE LOCATED ON CONTROL PANEL

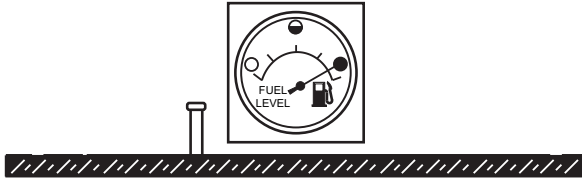

Figure 33. Full Fuel Tank

CAUTION

DO NOT OVERFILL the fuel system. Leave room for fuel expansion. Fuel expands when heated (Figure 34).



Figure 34. Fuel Expansion

COOLANT (ANTIFREEZE/SUMMER COOLANT/WATER)

Isuzu recommends antifreeze/summer coolant for use in their engines, which can be purchased in concentrate (and mixed with 50% demineralized water) or pre-diluted. See the **Isuzu Engine Owner's Manual** for further details.

WARNING



If adding coolant/antifreeze mix to the radiator, **DO NOT** remove the radiator cap until the unit has completely cooled. The possibility of **hot!** coolant exists which can cause severe burns.

Day-to-day addition of coolant is done from the recovery tank. When adding coolant to the radiator, **DO NOT** remove the radiator cap until the unit has completely cooled. See Table 12 for engine, radiator, and recovery tank coolant capacities.

NOTICE

Normally, only the coolant level in the recovery tank needs to be checked. However, the radiator cap should be opened once a week to verify that coolant is visible (full) inside the radiator.

- Verify that the coolant level in the coolant recovery tank is between the **FULL** and **LOW** markings as shown in Figure 35.

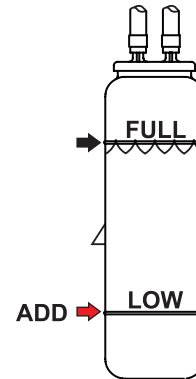

Figure 35. Coolant Recovery Tank

Table 12. Coolant Capacity

Engine and Radiator	4.44 gal. (16.8 liters)
Reserve Tank	0.29 gal (1.1 liters)

Operation in Freezing Weather

When operating in freezing weather, be certain the proper amount of antifreeze (Table 13) has been added.

Table 13. Antifreeze Operating Temperatures

Vol % Antifreeze	Freezing Point	
	°C	°F
50	-37	-34

NOTICE

When the antifreeze is mixed with water, the antifreeze mixing ratio **must be** less than 50%.

Cleaning the Radiator

The engine may overheat if the radiator cooling fins (Figure 36) become overloaded with dust or debris. Periodically clean the radiator fins with compressed air. Cleaning inside the machine is dangerous, so clean only with the engine turned off and the **negative** battery terminal disconnected.

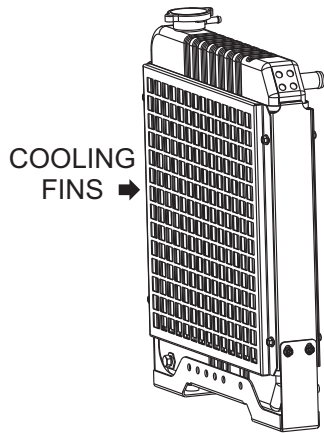

Figure 36. Radiator (Cooling Fins)

AIR CLEANER

Periodic cleaning/replacement of the air cleaner is necessary. Inspect the air cleaner (Figure 37) in accordance with the maintenance section of this manual or the **Isuzu Engine Owner's Manual**.

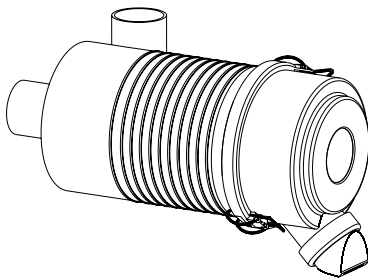

Figure 37. Air Cleaner

FAN BELT TENSION

A slack fan belt may contribute to overheating, or to insufficient charging of the battery. Inspect the fan belt for damage and wear and adjust it in accordance with the maintenance section of this manual or the **Isuzu Engine Owner's Manual**.

The fan belt tension is proper if the fan belt bends 0.22–0.24 in. (5.5–6.0 mm) when pressed with the thumb as shown in Figure 38.

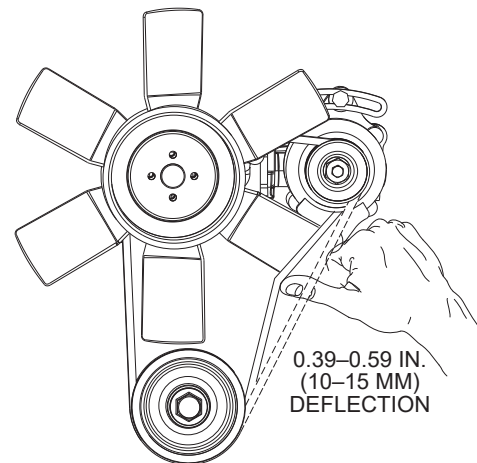

Figure 38. Fan Belt Tension

CAUTION



NEVER place hands near the belts or fan while the generator set is running.

BATTERY

This unit is of negative ground. **DO NOT** connect in reverse. Always maintain battery fluid level between the specified marks. Battery life will be shortened if the fluid levels are not properly maintained. Add only distilled water when replenishment is necessary.

DO NOT overfill. Check to see whether the battery cables are loose. Poor contact may result in poor starting or malfunctions. **ALWAYS** keep the terminals firmly tightened. Coat the terminals with an approved battery terminal treatment compound. Replace the battery with only the recommended type battery. The battery type used in this generator is BCI Group 27.

The battery is sufficiently charged if the specific gravity of the battery fluid is 1.28 (at 68°F). If the specific gravity should fall to 1.245 or lower, it indicates that the battery is dead and needs to be recharged or replaced.

Before charging the battery with an external electric source, be sure to disconnect the battery cables.

Battery Cable Installation

ALWAYS be sure the battery cables (Figure 39) are properly connected to the battery terminals as shown below. The **red cable** is connected to the positive terminal of the battery, and the **black cable** is connected to the negative terminal of the battery.

CAUTION

ALWAYS disconnect the negative terminal **FIRST** and reconnect the negative terminal **LAST**.

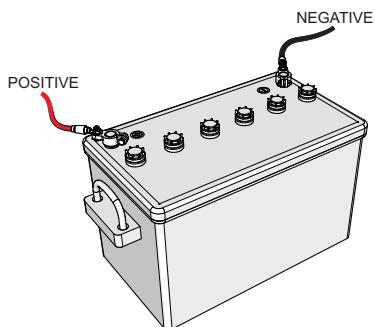

Figure 39. Battery Connections

When connecting the battery do the following:

1. **NEVER** connect the battery cables to the battery terminals when the **Auto-Off/Reset-Manual Switch** is in either the **AUTO** or **MANUAL** position. **ALWAYS** make sure that this switch is in the **OFF/RESET** position when connecting the battery.
2. Place a small amount of battery terminal treatment compound around both battery terminals. This will ensure a good connection and will help prevent corrosion around the battery terminals.

NOTICE

If the battery cable is connected incorrectly, electrical damage to the generator will occur. Pay close attention to the polarity of the battery when connecting the battery.

CAUTION

Inadequate battery connections may cause poor starting of the generator, and create other malfunctions.

ALTERNATOR

The polarity of the alternator is negative grounding type. When an inverted circuit connection takes place, the circuit will be in short circuit instantaneously, resulting in alternator failure.

DO NOT put water directly on the alternator. Entry of water into the alternator can cause corrosion and damage the alternator.

WIRING

Inspect the entire generator for bad or worn electrical wiring or connections. If any wiring or connections are exposed (insulation missing) replace wiring immediately.

PIPING AND HOSE CONNECTIONS

Inspect all piping, oil hose, and fuel hose connections for wear and tightness. Tighten all hose clamps and check hoses for leaks.

If any hose (fuel or oil) lines are defective replace them immediately.

GENERATOR START-UP PROCEDURE (MANUAL)

BEFORE STARTING

CAUTION

The engine's exhaust contains harmful emissions. **ALWAYS** have adequate ventilation when operating. Direct exhaust away from nearby personnel.

WARNING

NEVER manually start the engine with the main, GFCI or auxiliary circuit breakers in the **ON** (closed) position.

1. Place the **main, GFCI, and aux.** circuit breakers (Figure 40) in the **OFF** position prior to starting the engine.

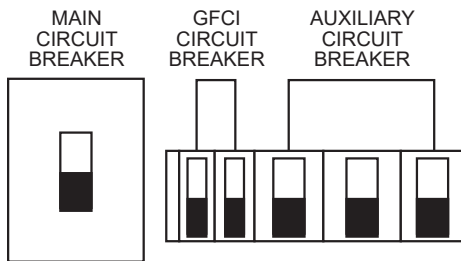

Figure 40. Main, Aux. and GFCI Circuit Breakers (OFF)

2. Make sure the **voltage selector switch** has been configured for the desired output voltage.
3. Connect the load to the **receptacles** or the **output terminal lugs** as shown in Figure 11. These load connection points can be found on the output terminal panel and the output terminal panel's hard wire hookup panel.
4. Tighten terminal nuts securely to prevent load wires from slipping out.
5. Close all engine enclosure doors (Figure 41).

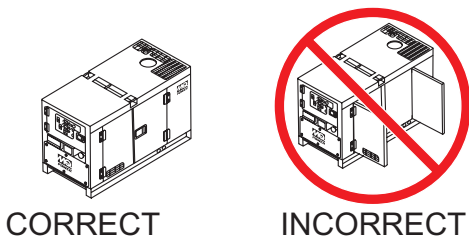

Figure 41. Engine Enclosure Doors

STARTING (MANUAL)

1. Place the **Auto-Off/Reset-Manual Switch** in the **MANUAL** position to start the engine (Figure 42).

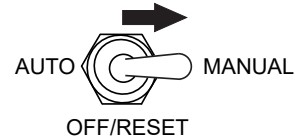

Figure 42. Auto-Off/Reset-Manual Switch (Manual Position)

NOTICE

If the engine fails to start within a specified number of attempts, the shutdown lamp will illuminate and the Auto-Off/Reset-Manual Switch must be placed in the Off/Reset position before the engine can be restarted.

NOTICE

The engine will pre-heat automatically in cold weather conditions. "Glow Plug Hold" message will be displayed and the engine will start automatically after pre-heating.

2. Once the engine starts, let the engine run for 1–2 minutes (let the engine idle longer in cold weather conditions). Listen for any abnormal noises. If any abnormalities exist, shut down the engine and correct the problem.
3. The generator's frequency meter (Figure 43) should be displaying the 60-cycle output frequency in **HERTZ**.

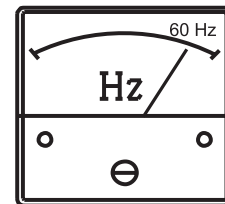

Figure 43. Frequency Meter

GENERATOR START-UP PROCEDURE (MANUAL)

4. The generator's AC voltmeter (Figure 44) will display the generator's output in **VOLTS**.

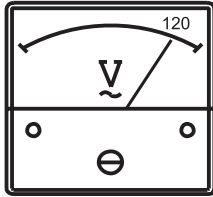

Figure 44. Voltmeter

5. If the voltage is not within the specified tolerance, use the voltage adjustment control knob (Figure 45) to increase or decrease the desired voltage.



Figure 45. Voltage Adjust Control Knob

6. The ammeter (Figure 46) will indicate **zero amps** with no load applied. When a load is applied, the ammeter will indicate the amount of current that the load is drawing from the generator.

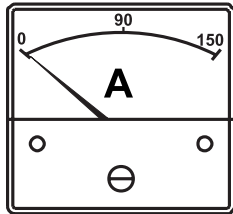

Figure 46. Ammeter (No Load)

7. The **engine oil pressure gauge** (Figure 47) will indicate the oil pressure of the engine. Under normal operating conditions the oil pressure should be between 35 and 65 psi (193–586 kPa).

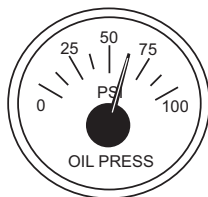

Figure 47. Oil Pressure Gauge

8. The **coolant temperature gauge** (Figure 48) will indicate the coolant temperature. Under normal operating conditions the coolant temperature should be approximately 180°F (82°C).

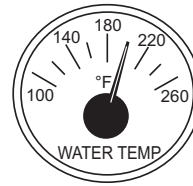

Figure 48. Coolant Temperature Gauge

9. The **tachometer gauge** (Figure 49) will indicate the speed of the engine when the generator is operating. Under normal operating conditions this speed is approximately 1,800 rpm.

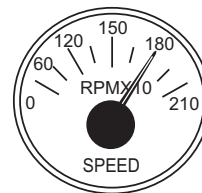

Figure 49. Engine Tachometer Gauge

10. Place the **main, GFCI, and aux.** circuit breakers in the **ON** position (Figure 50).

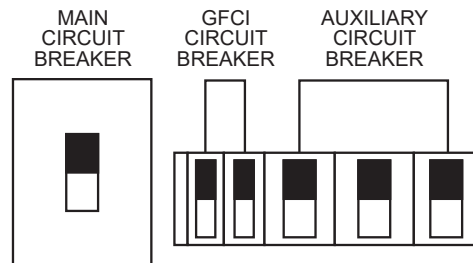

Figure 50. Main, Aux. and GFCI Circuit Breakers (ON)

11. Observe the generator's ammeter (Figure 51) and verify it reads the anticipated amount of current with respect to the load. The ammeter will only display a current reading if a load is in use.

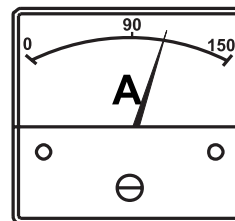

Figure 51. Ammeter (Load)

12. The generator will run until manually stopped or an abnormal condition occurs.

GENERATOR START-UP PROCEDURE (AUTO MODE)

STARTING (AUTO MODE)

DANGER



Before connecting this generator to any building's electrical system, a **licensed electrician** must install an **isolation (transfer) switch**. Serious damage to the building's electrical system may occur without this transfer switch.

CAUTION

When connecting the generator to an isolation (transfer) switch, **ALWAYS** have power applied to the generator's internal battery charger. This will ensure that the engine will not fail due to a dead battery.

NOTICE

When the generator is set in the **AUTO** mode, the generator will **automatically start** in the event of commercial power falling below a prescribed level by means of a contact closure that is generated automatically by a transfer switch.

WARNING

When running the generator in the **AUTO** mode, remember the generator can start up at any time without warning. **NEVER** attempt to perform any maintenance when the generator is in the auto mode.

CAUTION

The engine speed switch **must** be set to the "High" position when running in the **auto-start** mode. Failing to set the switch in the proper position can result in damage to your generator when it turns on.

NOTICE

When the **Auto Off/Reset Manual** switch is placed in the **AUTO** position, the engine glow plugs will be warmed and the engine will start automatically.

When starting the generator in **AUTO** mode use the "Manual Start-Up" procedure except where noted (see below).

1. Perform steps 1 through 5 in the Before Starting section as outlined in the Manual Starting Procedure.
2. Place the **Auto Off/Reset Manual Switch** (Figure 52) in the **AUTO** position.



Figure 52. Auto Off/Reset Manual Switch (AUTO)

3. Continue operating the generator as outlined in the Manual Start-Up procedure (start at step 3).

GENERATOR SHUTDOWN PROCEDURE

WARNING

NEVER stop the engine suddenly except in an emergency.

NORMAL SHUTDOWN PROCEDURE

To shut down the generator, use the following procedure:

1. Place the **MAIN, GFCI and LOAD** circuit breakers as shown in Figure 53 to the **OFF** position.

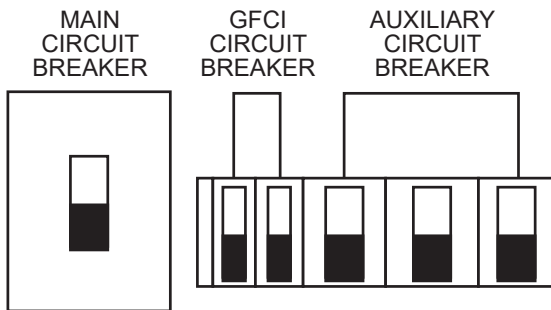

Figure 53. Main, Aux. and GFCI Circuit Breakers (OFF)

2. Let the engine cool by running it at low speed for 3–5 minutes with no load applied.
3. Place the **Auto Off/Reset Manual Switch** (Figure 54) in the **OFF/RESET** position.



Figure 54. Auto Off/Reset Manual Switch (Off/Reset)

4. Verify that all status LEDs on the ECU control panel are **OFF** (not lit).
5. Remove all loads from the generator.
6. Inspect the entire generator for any damage or loosening of components that may have occurred during operation.

EMERGENCY SHUTDOWN PROCEDURE

NOTICE

The Emergency Stop Pushbutton Switch should only be used to stop the engine in case of an emergency or to lock out operation during service. The emergency stop switch should **NEVER** be used for routine stopping of the engine.

1. To stop the engine in the event of an emergency, push the **Emergency Stop Pushbutton Switch** (Figure 55). Activating the Emergency Stop Switch will cause the contacts on the main breaker to **OPEN**.

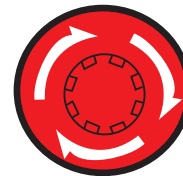

Figure 55. Emergency Stop Button

2. The emergency stop switch is a push-locked type switch. The switch contact can only be released by rotating the button in the clockwise direction. The engine can not be restarted until the contact is released (**closed**).
3. Place the **MAIN, GFCI and LOAD** circuit breakers as shown in Figure 53 to the **OFF** position.

AUTOMATIC SHUTDOWN SYSTEM

This unit is equipped with safety devices to automatically stop the engine in the event of low oil pressure, approximately 14 psi (97 kPa), high water temperature, approximately 212°F (100°C), or overspeed approximately +15%. The alarm lamps on the ECU illuminate to signify the reason for the shutdown.

NOTICE

Before inspecting the generator, check that the Auto/Manual switch is in the **OFF/RESET** position, and place all circuit breakers in the **OFF** position. Allow sufficient time for adequate cooling. When ready to restart, complete all steps in the Generator Startup Procedure section of this manual.

MAINTENANCE

Table 14. Inspection/Maintenance		10 Hrs. DAILY	250 Hrs.	500 Hrs. or Every 12 Months	3,000 Hrs. or Every 36 Months	OTHER
Engine	Check Engine Oil and Coolant Levels	X				
	Check Fuel Filter/Water Separator Bowl	X				
	Check Air Cleaner	X				
	Check Air Cleaner Element	X				
	Check for Leaks/Hoses/Clamps	X				
	Check for Loosening of Parts	X				
	Drain Water in Fuel	X				
	Change Engine Oil and Oil Filter * 1		X			
	Clean Unit, Inside and Outside		X			
	Replace Fuel Filter Elements			X		
	Check Engine Mounts			X		
	Service Battery			X		
	Check Air Intake Hoses			X		
	Check Fan Belt Condition (Replace if Necessary)	X				
	Check Automatic Belt Tensioner	X				
	Check Electrical Ground Connection			X		
	Clean Radiator, Check Cooling System			X		
	Coolant Solution Analysis, Add SCAs as Required			X		
	Pressure Test Cooling System			X		
	Check Engine Speed			X		
	Test Thermostats				X	
	Test Glow Plugs				X	
	Flush and Refill Cooling System					2 yrs. or 2,000 hrs.
	Clean Inside of Fuel Tank					1,000 hrs.
	Replace Air Cleaner Elements * 3					As Required
	Check Battery Acid Level	X				
Drain Environmental Tank			X			
Check All Hoses and Clamps					1,000 hrs.	
Generator	Measure Insulation Resistance Over 3M Ohms		X			
	Check Rotor Rear Support Bearing			X		

*1 During initial operation of a new engine, change oil and filter between a minimum of 100 hours and a maximum of 250 hours. Service interval depends on type of oil.

*2 Add "Supplemental Coolant Additives" (SCAs) to recharge the engine coolant.

*3 Replace the primary air filter element when the restriction indicator shows a vacuum of 625 mm (25 in. H₂O).

*4 If the blowby hose needs to be replaced, ensure that the slope of the blowby hose is at least 1/2 inch per foot, with no sags or dips that could collect moisture and/or oil.

*5 Accumulation of carbon (soot, unburned fuel) in the exhaust pipe line and muffler could cause not only system derates but also could lead to fire incident. To destroy the soot and unburned fuel, run the unit at rated power for some period of time until the exhaust gas become mostly colorless every 250 hours of operation time. The carbon will be easier to be generated when the unit operates at less then 40% of rated power. In this case, perform the above procedures at a shorter interval time.

*6 Applying a large load at one time to the unit when carbon deposits have accumulated in the exhaust system could produce fire/sparks which could lead to abnormal combustion. Therefore it is recommended to **apply the load gradually** and observe the exhaust gas color (colorless) during the process.

*7 Fire or sparks may emit from the exhaust gas outlet during the **carbon emission accumulation check** (load). Make sure the area surrounding the unit is free from any **flammable** material.

GENERAL INSPECTION

Prior to each use, the generator should be cleaned and inspected for deficiencies. Check for loose, missing or damaged nuts, bolts or other fasteners. Also check for fuel, oil, and coolant leaks. Use Table 14 as a general maintenance guideline **Engine Side** (Reference Engine Instruction Manual).

AIR CLEANER

NOTICE

If the engine is operating in very **dusty** or **dry** grass conditions, a clogged air cleaner will result. This can lead to a loss of power, excessive carbon buildup in the combustion chamber and high fuel consumption. Change air cleaner more **frequently** if these conditions exist.

Every 250 hours: Remove the air cleaner element (Figure 56) and clean the heavy-duty paper element with a light spray of compressed air. Replace the air cleaner as needed.

This Isuzu diesel engine is equipped with a replaceable, high-density, paper air cleaner element. This air cleaner is also equipped with an inner element (secondary) that is used as a backup filter should the primary element become damaged.

CAUTION



Wear protective equipment such as approved safety glasses or face shields and dust masks or respirators when cleaning air filters with compressed air.

Primary and Secondary Air Cleaner Elements

1. Release the latches (Figure 56) that secure the cover to the air cleaner body.
2. Remove the air cleaner cover and set it aside.
3. Remove both the primary and secondary air cleaner elements.
4. Check the air cleaner daily or before starting the engine.
5. Check for and correct heavy buildup of dirt and debris along with loose or damaged components.

NOTICE

Operating the engine with loose or damaged air cleaner components could allow unfiltered air into the engine causing premature wear and failure.

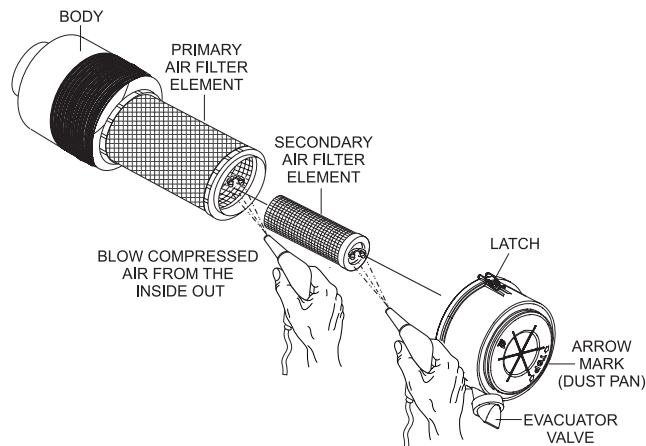

Figure 56. Air Cleaner

6. To clean the primary element (paper air filter) as referenced in Figure 56, tap the filter element several times on a hard surface to remove dirt, or blow compressed air, not to exceed 30 psi (207 kPa, 2.1 kgf/cm²), through the filter element from the inside out.
7. Clean the secondary element (paper air filter) as referenced in step 6.
8. Replace both elements if they are damaged or excessively dirty.
9. Clean the inside of the air cleaner body.
10. Reinstall the primary and secondary air filter elements back into the air cleaner body.
11. Reinstall the air cleaner cover and secure with latches.

NOTICE

DO NOT run the engine with the air cleaner removed or without an element.

DRAINING THE FUEL FILTER ELEMENT

NOTICE

Inspect the fuel filter **daily**. If the fuel filter (Figure 57) has collected a significant amount of water and sediment at the bottom of the cup, it should be drained off immediately.

1. Loosen the air bleeder plug (Figure 57) on the fuel filter body.
2. To discharge the fuel inside the fuel filter, **OPEN** the drain valve on the fuel filter by turning the knob **counterclockwise (A)** approximately 3-1/2 turns until the valve drops down 1 inch (25.4 mm) and draining occurs (**B**).

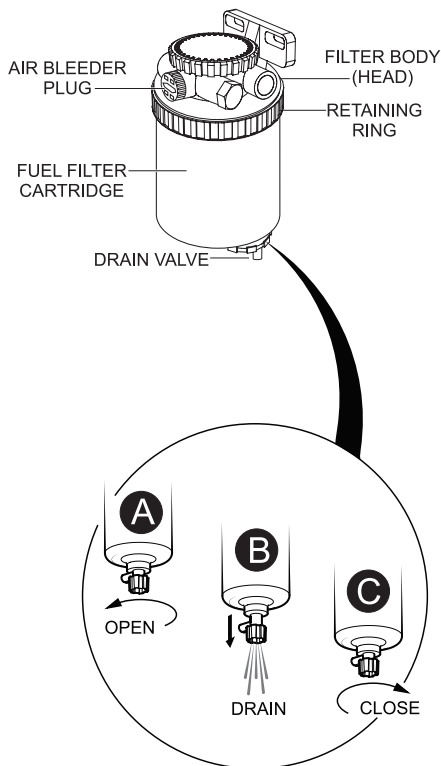

Figure 57. Draining Fuel Filter

3. Let the residue or foreign substances inside the case flow into a suitable container.

FUEL FILTER ELEMENT REPLACEMENT

1. Use a filter wrench to remove the element case (Figure 58) from the fuel filter body.

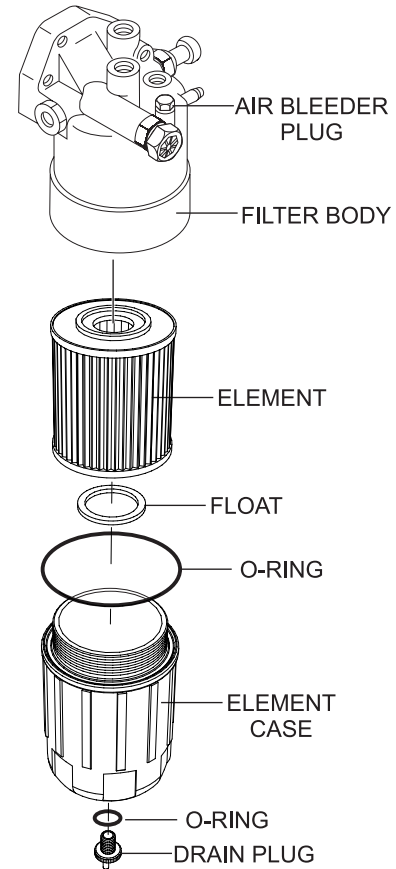

Figure 58. Fuel Filter Replacement

2. Wipe the inside of the filter body with a clean cloth to remove any foreign matter or debris that may have accumulated.
3. Insert the new fuel filter element into the element case.
4. Replace both O-rings. Coat each O-ring with a small amount of clean 15W-40 engine oil.
5. Reinstall the element case first by hand until it makes contact with the fuel filter body surface.
6. Torque the element case to 22.4 lbf·ft (30 N·m).
7. Torque the drain plug to 1.4 lbf·ft (2.0 N·m).
8. Remove the air from the fuel system. Reference the Isuzu Owner's Manual, "Bleeding the Fuel System."

ELECTROMAGNETIC FUEL PUMP (500 HOURS)

The filter inside the fuel pump (Figure 59) is either a paper type or steel mesh type depending on the fuel pump type. Clean or replace the fuel pump filter as follows:

1. Disconnect any electrical connections that are attached to the fuel pump.
2. Prepare a fuel collector to drain the fuel into. Secure any fuel lines to prevent fuel from spilling.
3. Remove the fuel pump from the generator enclosure.
4. Remove the filter and gasket from the fuel pump housing.

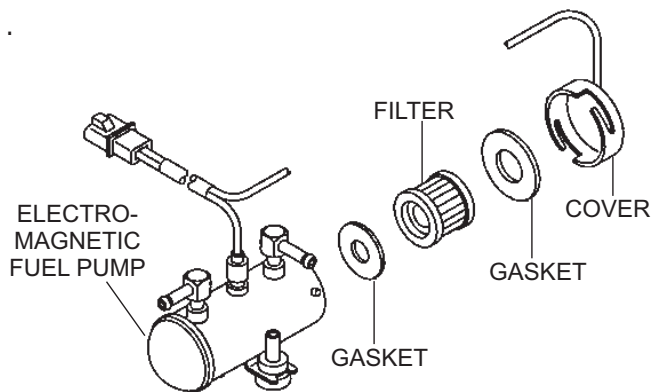

Figure 59. Electromagnetic Fuel Pump

NOTICE

When the fuel pump filter is removed, always make sure to replace both gaskets and clean the magnet portion inside the cover.

5. Clean or replace the fuel pump filter. Replace both gaskets.
6. Reassemble the fuel pump and mount it back onto the generator enclosure.
7. Reconnect all fuel lines and electrical components.
8. Check for fuel leaks.

DRAINING THE CONTAINMENT TANK

1. This generator is equipped with an environmental containment tank. Inspect this tank regularly.
2. If the tank becomes full with fluids, remove the drain bolt (Figure 60), then allow the fluids to drain into a suitable container.

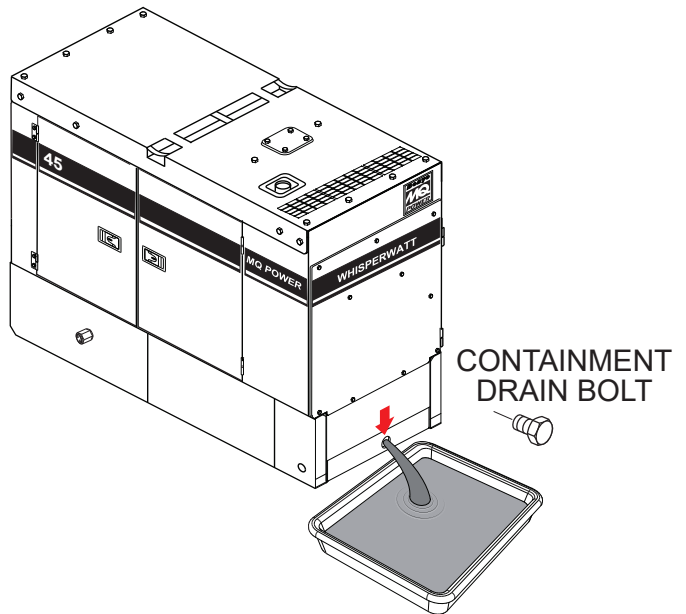

Figure 60. Draining Containment Tank

CLEANING INSIDE THE FUEL TANK

If necessary, drain the fuel inside the fuel tank completely. Using a spray washer (Figure 61) wash out any deposits or debris that have accumulated inside the fuel tank.

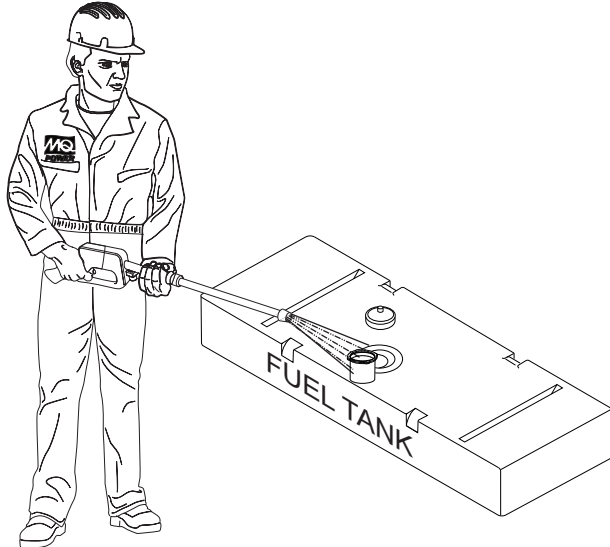

Figure 61. Fuel Tank Cleaning

FUEL TANK INSPECTION

In addition to cleaning the fuel tank, the following components should be inspected for wear:

- **Rubber Suspension** — Look for signs of wear or deformity due to contact with oil. Replace the rubber suspension if necessary.
- **Fuel Hoses** — Inspect nylon and rubber hoses for signs of wear, deterioration or hardening.
- **Fuel Tank Lining** — Inspect the fuel tank lining for signs of excessive amounts of oil or other foreign matter.

DRIVE BELT (DAILY)

Drive Belt Tension

A slack drive belt (Figure 62) may contribute to overheating or insufficient charging of the battery. Adjust the drive belt in accordance with the Isuzu Operator's manual.

Drive Belt Inspection

Inspect the drive belt for damage and wear. Horizontal cracks (across the belt) are acceptable. Vertical (direction of belt ribs) cracks that intersect with horizontal cracks are not acceptable.

Also, examine the belt and determine if it is **oil soaked** or **“glazed”** (a hard shiny appearance on the sides of the belt). Either of these two conditions can cause the belt to run hot, which can weaken it and increase the danger of it breaking.

If the drive belt exhibits any of the above wear conditions, replace the drive belt immediately.

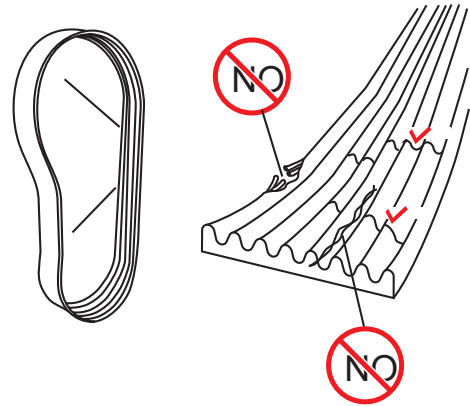

Figure 62. Drive Belt Inspection

DRAINING ENGINE OIL

1. Run the engine until the engine coolant reaches a temperature of 140°F (60°C). Turn the engine off.
2. Remove the oil dipstick from its holder.
3. Next, remove the **oil drain cap** (Figure 63).
4. Place the **oil drain valve** in the **OPEN** position and allow the oil to drain into a suitable container.

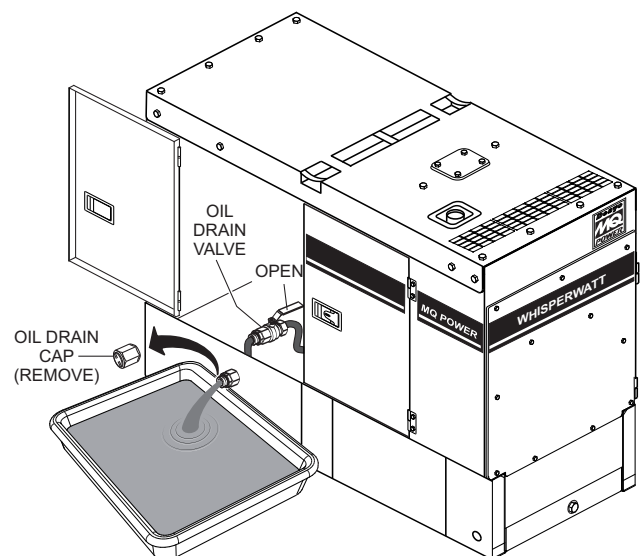

Figure 63. Draining Engine Oil

- After the engine oil has been completely drained, reinstall the oil drain cap and tighten securely.
- Place the **oil drain valve** in the **CLOSED** position.

ENGINE OIL FILTER REPLACEMENT

- Clean the area around the lubricating oil filter head.
- Using an oil filter wrench (Figure 64), remove the engine oil filter.

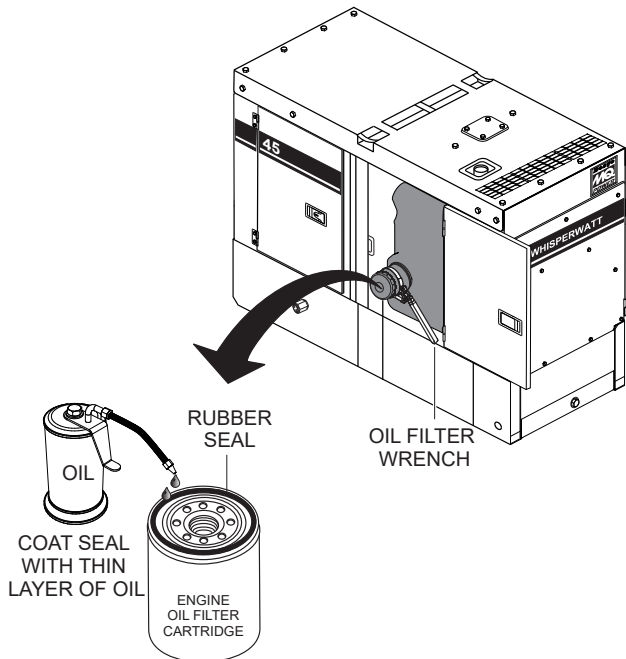

Figure 64. Oil Filter Removal

- Coat the rubber seal (gasket) surface of the oil filter (Figure 64) with clean 15W-40 engine oil.
- Install the new oil filter (main) first by hand until it makes contact with the filter head surface. Tighten it another 3/4 turn using the filter wrench.
- Fill the engine crankcase with high-quality detergent oil classified "For Service CI-4." Fill to the upper limit of the dipstick. **DO NOT** overfill. Reference Table 2 for engine crankcase oil capacity.
- Run the engine for several minutes. Watch for oil leakage. Shut the engine down and allow it to sit for several minutes. Top off the oil to the upper limit on the dipstick.

DRAINING ENGINE COOLANT

WARNING

DO NOT remove the pressure cap from the radiator when the engine is hot! Wait until the coolant temperature is below 120°F (50°C) before removing the pressure cap.

Heated coolant spray or steam can cause severe scalding and personal injury.

- Remove the radiator pressure cap (Figure 65) only if the coolant temperature is below 120°F (50°C).

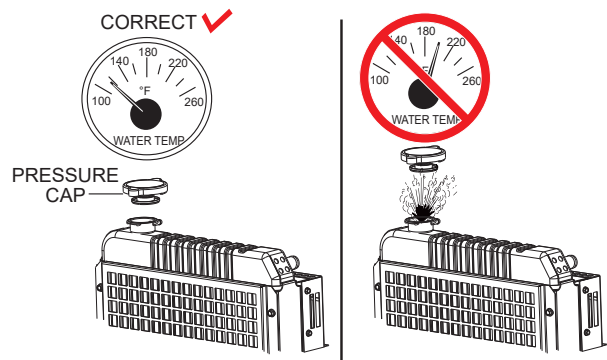

Figure 65. Radiator Pressure Cap Removal

- Open the cabinet door and remove the coolant drain bolt and O-ring (Figure 66), then allow the coolant to drain into a suitable container.

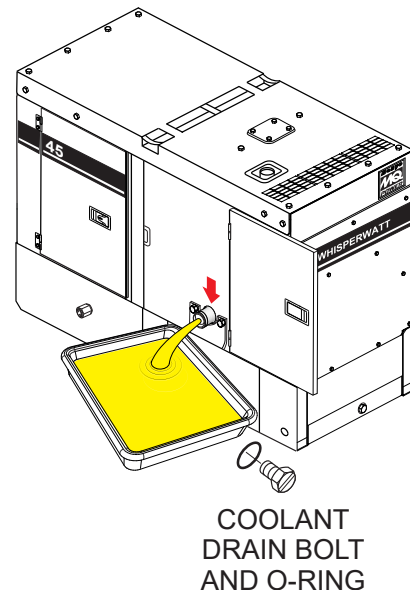



Figure 66. Draining Radiator Coolant

FLUSHING OUT THE RADIATOR AND REPLACING COOLANT

- Open both cocks located at the crankcase side and at the lower part of the radiator and drain the coolant. Open the radiator cap while draining. Remove the overflow tank and drain.
- Check hoses for softening and kinks. Check clamps for signs of leakage.
- Tighten both cocks and replace the overflow tank.
- Replace with coolant as recommended by the engine manufacturer.
- Close the radiator cap tightly.
- Flush the radiator by running clean tap water through the radiator until signs of rust and dirt are removed. **DO NOT** clean the radiator core with any objects, such as a screwdriver.

WARNING



Allow the engine to **cool** when flushing out the radiator. Flushing the radiator while hot could cause serious burns from water or steam.

RADIATOR CLEANING

The radiator (Figure 67) should be sprayed (cleaned) with a high-pressure washer when excessive amounts of dirt and debris have accumulated on the cooling fins or tube. When using a high-pressure washer, stand at least 5 feet (1.5 meters) away from the radiator to prevent damage to the fins and tube.



Figure 67. Radiator Cleaning

TESTING THE GFCI RECEPTACLE

NOTICE

The GFCI receptacle is designed to interrupt power when a ground fault exists to prevent injuries and shock hazards. **DO NOT** use the GFCI receptacle if the test below fails. Consult a qualified electrician for repair or replacement of the GFCI receptacle. Test the GFCI receptacle **at least once a month**.

1. Start the generator as outlined in the start-up procedure in this manual.
2. Place a GFCI circuit breaker (Figure 68) in the **ON** position.

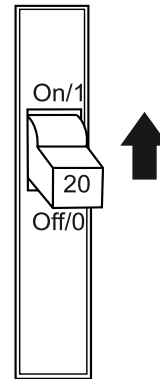

Figure 68. GFCI Circuit Breaker

3. Verify that the status LED on the corresponding GFCI receptacle (Figure 69) is **ON (GREEN)**.

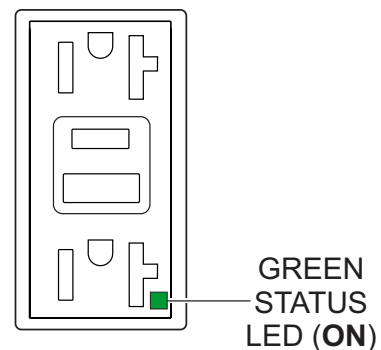

Figure 69. GFCI Receptacle (ON)

4. Plug a power tool into the GFCI receptacle such as an electric drill (Figure 70). Squeeze the ON/OFF switch on the drill and verify that the drill turns on.

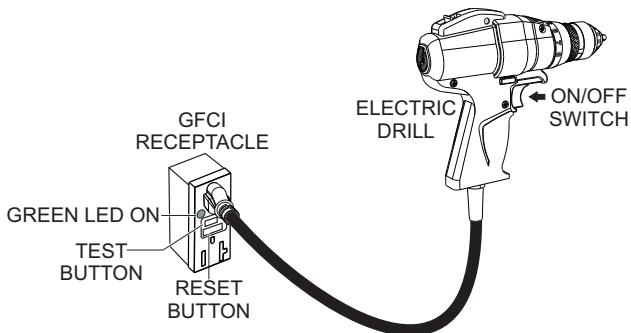

Figure 70. GFCI Receptacle Test

5. Continue holding down the ON/OFF switch on the drill and at the same time press the **TEST** button on the GFCI receptacle.
6. Verify that the drill turns off when the **TEST** button is pressed and that the status LED on the GFCI receptacle turns **OFF** (Figure 71).

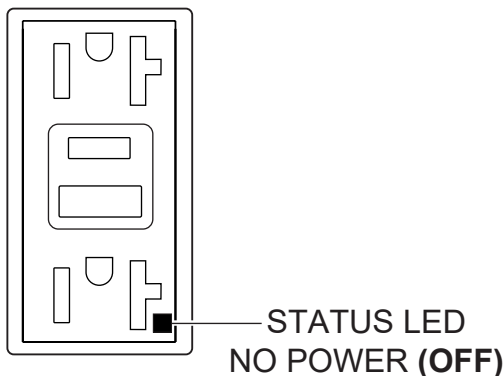

Figure 71. GFCI Receptacle (OFF)

NOTICE

If the drill motor continues to run after the **TEST** button is pressed then it can be determined that the GFCI receptacle is not working properly and should be replaced.

7. Press the **RESET** button to restore power to the GFCI receptacle. To ensure power has been restored, squeeze the ON/OFF switch on the drill and verify that the drill turns on. Status LED on the GFCI receptacle should be **ON (GREEN)**.

8. If the status LED (Figure 72) is **flashing (RED)**, **DO NOT** use the GFCI receptacle and replace it immediately.

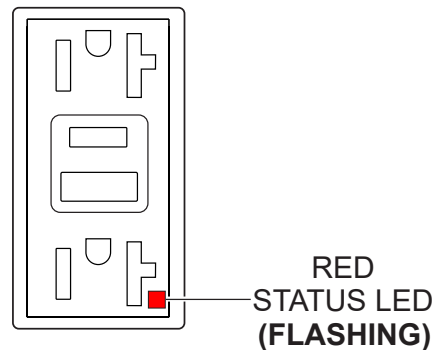

Figure 72. GFCI Receptacle (Red Flashing LED)

9. Repeat the above procedure for any other GFCI receptacles.

GENERATOR STORAGE

For long-term storage of the generator the following is recommended:

- Drain the fuel tank completely. Treat with a fuel stabilizer if necessary.
- Completely drain the oil from the crankcase and refill if necessary with fresh oil.
- Clean the entire generator, internal and external.
- Cover the generator and store in a clean, dry place.
- Disconnect the battery.
- Make sure engine coolant is at the proper level.
- If the generator is mounted on a trailer, jack the trailer up and place it on blocks so the tires do not touch the ground, or block and completely remove the tires.

JACKET WATER HEATER AND INTERNAL BATTERY CHARGER 120 VAC INPUT RECEPTACLES (OPTIONAL)

This generator can be equipped with an **engine block heating element** and an **internal battery charger** as **options**. They are provided with electric cords to connect to a commercial power source.

The engine block heating element and internal battery charger both require 120 VAC in order to operate. A receptacle (Figure 73) has been provided on the output terminal panel to allow commercial power to be applied.

These receptacles will **ONLY** function when commercial power has been supplied to them (Figure 73). To apply commercial power to these receptacles, a power cord of adequate size will be required (See Table 6).

When using the generator in **hot** climates there is no reason to apply power to the jacket water heater. However, if the generator will be used in **cold** climates it is always a good idea to apply power to the jacket water heater at all times.

If the generator will be used daily, the battery should normally not require charging. If the generator will be idle (not used) for long periods of time, apply power to the battery charger receptacle via commercial power using a power cord of adequate size.

NOTICE

If the generator will be idle (not used) for long periods of time and to ensure adequate starting capability, always have power applied to the generator's internal battery charger.

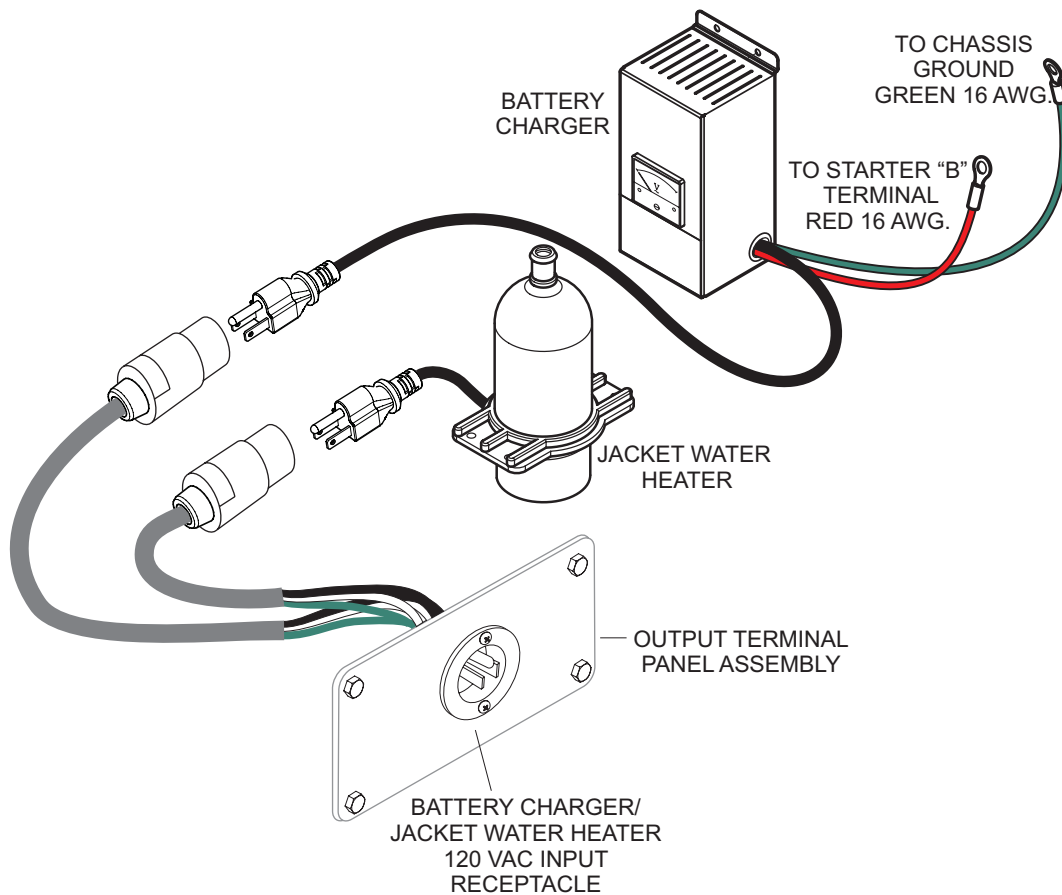

Figure 73. Battery Charger and Jacket Water Heater (Option)

EMISSION CONTROL

The emission control system employed with the Isuzu 4LE2T diesel engine consists of a Diesel Oxidation Catalyst (DOC).

This device oxidizes large amounts of harmful nitrogen oxides (NO_x) and particulate matter (PM) which are emitted by diesel engines. These exhaust emissions pose serious environmental and health risks. No maintenance or service is required for the DOC device used on this generator.

Diesel Oxidation Catalyst (DOC)

The DOC (Figure 74) does not filter particles, it oxidizes them. This catalyst (honeycomb-like structure) uses a chemical process to break down pollutants in the exhaust stream into less harmful components. In general this catalyst collects/burns accumulated particulates. The DOC contains palladium and platinum which serve as catalysts to oxidize hydrocarbons and carbon monoxide.

EMISSION CARBON CHECK

Deposition of carbon (soot, unburned fuel) in the exhaust pipe line and muffler could cause not only system derates but also could lead to fires.

To reduce soot and unburned fuel, run the unit at rated power until the exhaust gas becomes mostly colorless every 250 hours of operation time. More carbon will be generated when the unit operates at less than 30% of rated power. In this case, perform the above procedures more frequently.

NOTICE

Applying a large load suddenly to the unit when carbon deposition has been generated in the exhaust system could produce sparks and will lead to abnormal combustion. Therefore, apply load gradually and observe the exhaust gas color during the process.

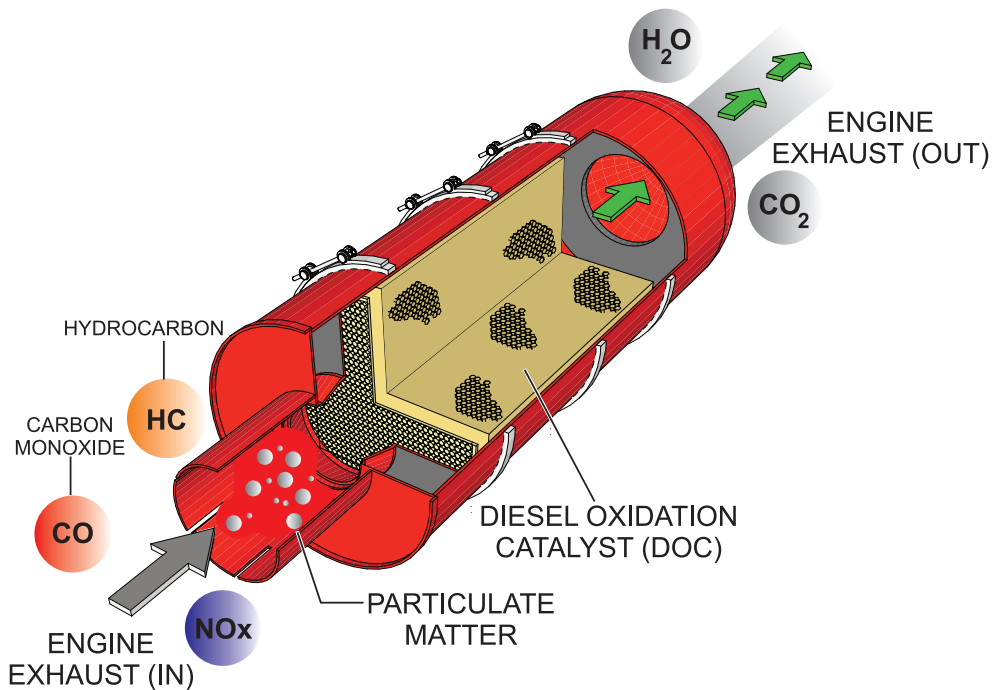

Figure 74. Diesel Oxidation Catalyst (DOC)

TROUBLESHOOTING (DIAGNOSTICS)

The engine controller of this generator diagnoses problems (faults/errors) that arise from the engine control system and the engine itself.

When any engine faults occur during operation of the generator the **warning lamp** (diagnostic lamp) located on the control panel will turn on. If this condition occurs please perform immediately the engine fault code diagnostic procedure below.

ENGINE FAULT CODE DIAGNOSTIC PROCEDURE

1. Remove all loads from the generator and place all circuit breakers in the **OFF** position.
2. Stop the engine.
3. Release the retaining screws that secure the control panel to the generator frame.
4. Slowly let the control panel fall forward so that the control box is exposed.
5. To start the diagnostic process, place the **diagnostic switch** to the **ON** (Figure 75) position.

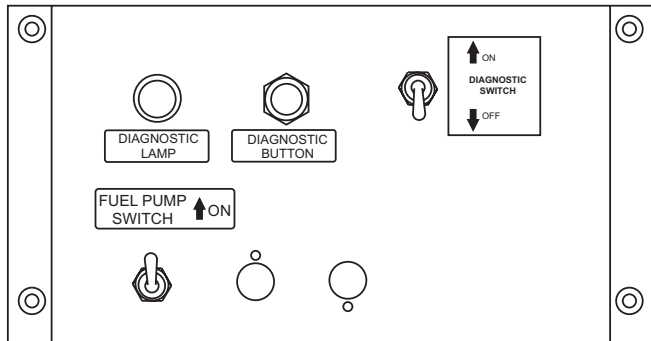

Figure 75. Diagnostic Panel

NOTICE

Make sure to place the diagnostic switch back to the **OFF** position after completing engine fault code diagnostic procedures.

6. Verify that the **diagnostic lamp** is **ON**. This indicates that there is a fault/error in the engine or the engine control system.
7. Push and hold the **diagnostic button** to identify the fault and verify the following:
 - The diagnostic lamp will start blinking with a pattern according to the detected fault code 3 times at an interval rate of 2.4 seconds.
 - If two or more fault codes are detected the diagnostic lamp will repeat the detected fault codes' blinking patterns in ascending order. After all the detected fault codes are shown, the process will repeat starting with the first fault code.
 - If no fault is detected the diagnostic lamp will blink repeatedly at an interval rate of 2.4 seconds.

NOTICE

For a complete understanding of error codes and troubleshooting procedures, refer to the enclosed engine instruction manual.

NOTICE

The diagnostic lamp will indicate the current fault code with the previous fault code in ascending order.

Also when a fault is detected the fault code will automatically be saved as the previous code in the ECM even after the fault has been repaired.

NOTICE

If a fault occurs while the engine is running the diagnostic lamp will turn on indicating only the current fault. Please note that the fault code (blinking pattern) cannot be shown while the engine is running.

TROUBLESHOOTING (GENERATOR)

Practically all breakdowns can be prevented by proper handling and maintenance inspections, but in the event of a breakdown, use Table 15 shown below for diagnosis of the generator. If the problem cannot be remedied, consult our company's business office or service plant.

Table 15. Generator Troubleshooting		
Symptom	Possible Problem	Solution
No Voltage Output	AC Voltmeter defective?	Check output voltage using a voltmeter.
	Is wiring connection loose?	Check wiring and repair.
	Is AVR defective?	Replace if necessary.
	Defective Rotating Rectifier?	Check and replace.
	Defective Exciter Field?	Check for approximately 19 ohms across J & K on CN1.
Low Voltage Output	Is engine speed correct?	Place engine throttle engine speed switch in "High" position.
	Is wiring connection loose?	Check wiring and repair.
	Defective AVR?	Replace if necessary.
High Voltage Output	Is wiring connection loose?	Check wiring and repair.
	Defective AVR?	Replace if necessary.
Circuit Breaker Tripped	Short Circuit in load?	Check load and repair.
	Over current?	Confirm load requirement and reduce.
	Defective circuit breaker?	Check and replace.
	Overcurrent Relay actuated?	Confirm load requirement and replace.

TROUBLESHOOTING (ENGINE)

Troubleshooting (Engine)		
Symptom	Possible Problem	Solution
Engine will not start or start is delayed, although engine can be turned over.	No Fuel reaching injection pump?	Add fuel. Check entire fuel system.
	Defective fuel pump?	Replace fuel pump.
	Fuel filter clogged?	Replace fuel filter and clean tank.
	Faulty fuel supply line?	Replace or repair fuel line.
	Compression too low?	Check piston, cylinder and valves. Adjust or repair per engine repair manual.
	Fuel pump not working correctly?	Repair or replace fuel pump.
	Oil pressure too low?	Check engine oil pressure.
	Low starting temperature limit exceeded?	Comply with cold starting instructions and proper oil viscosity.
	Defective battery?	Charge or replace battery.
	Air or water mixed in fuel system?	Check carefully for loosened fuel line coupling, loose cap nut, etc.
At low temperatures engine will not start.	Engine oil too thick?	Refill engine crankcase with correct type of oil for winter environment.
	Defective battery?	Replace battery.
Engine fires but stops soon as starter is switched off.	Fuel filter blocked?	Replace fuel filter.
	Fuel supply blocked?	Check the entire fuel system.
	Defective fuel pump?	Replace fuel pump.
Engine stops by itself during normal operation.	Fuel tank empty?	Add fuel.
	Fuel filter blocked?	Replace fuel filter.
	Defective fuel pump?	Replace fuel pump.
	Mechanical oil pressure shutdown sensor stops the engine due to low oil?	Add oil. Replace low oil shutdown sensor if necessary.
Low engine power, output and speed.	Fuel tank empty?	Replace fuel filter.
	Fuel filter clogged?	Replace fuel filter.
	Fuel tank venting is inadequate?	Ensure that tank is adequately vented.
	Leaks at pipe unions?	Check threaded pipe unions tape and tighten unions as required.
	Speed control lever does not remain in selected position?	See engine manual for corrective action.
	Engine oil level too full?	Correct engine oil level.
	Injection pump wear?	Use No. 2-D diesel fuel only. Check the fuel injection pump element and delivery valve assembly and replace as necessary.

TROUBLESHOOTING (ENGINE)

Troubleshooting (Engine) - continued		
Symptom	Possible Problem	Solution
Low engine power output and low speed, black exhaust smoke.	Air filter blocked?	Clean or replace air filter.
	Incorrect valve clearances?	Adjust valves per engine specification.
	Malfunction at injector?	See engine manual.
Engine overheats.	Too much oil in engine crankcase?	Drain off engine oil down to uppermark on dipstick.
	Entire cooling air system contaminated/ blocked?	Clean cooling air system and cooling fin areas.
	Fan belt broken or elongated?	Change belt or adjust belt tension.
	Coolant insufficient?	Replenish coolant.
	Radiator net or radiator fin clogged with dust?	Clean net or fin carefully.
	Fan, radiator, or radiator cap defective?	Replace defective part.
	Thermostat defective?	Check thermostat and replace if necessary.
Head gasket defective or water leakage?	Replace parts.	

GENERATOR WIRING DIAGRAM (M18141000403B)

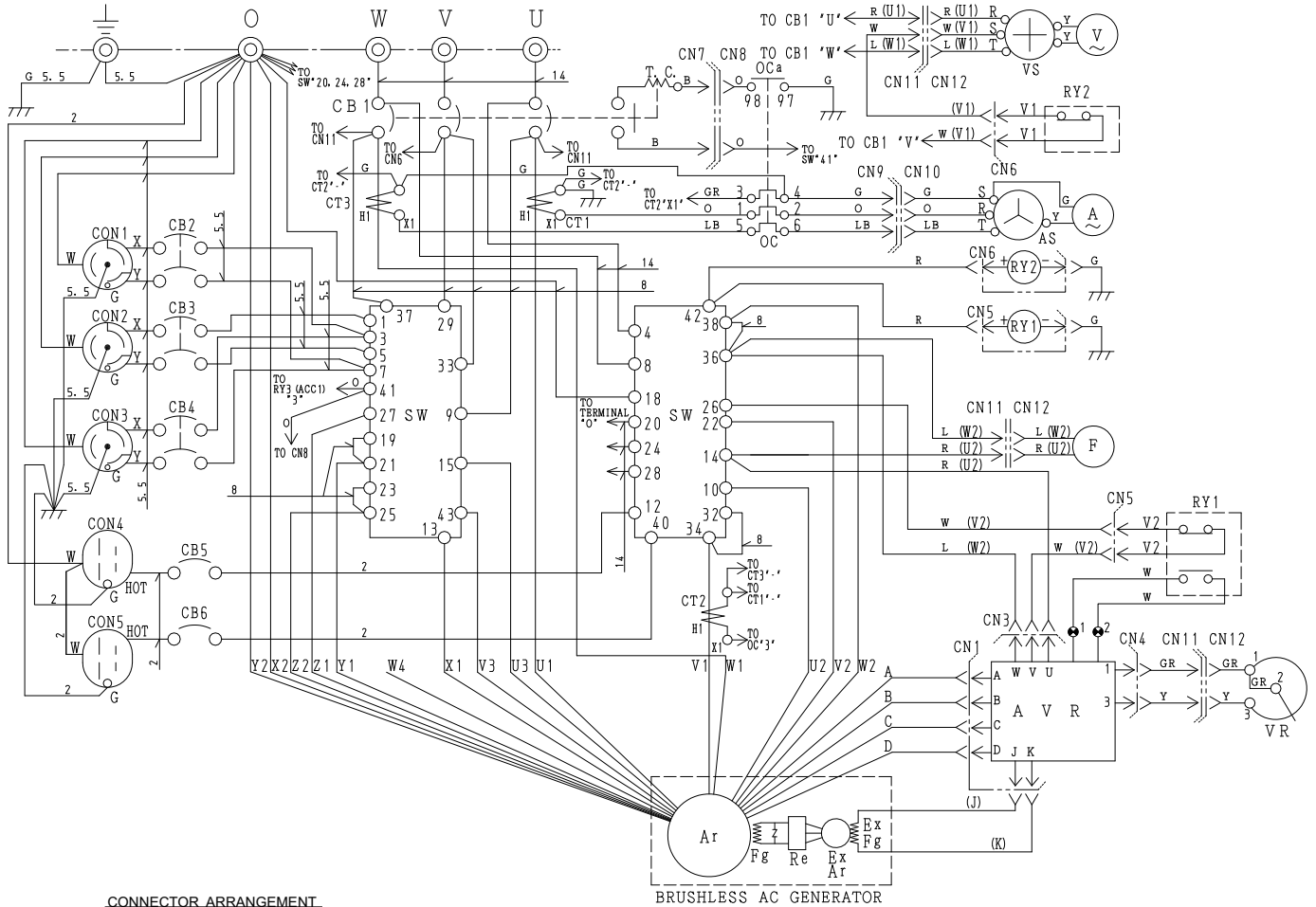

CONNECTOR ARRANGEMENT
(WIRING VIEW)

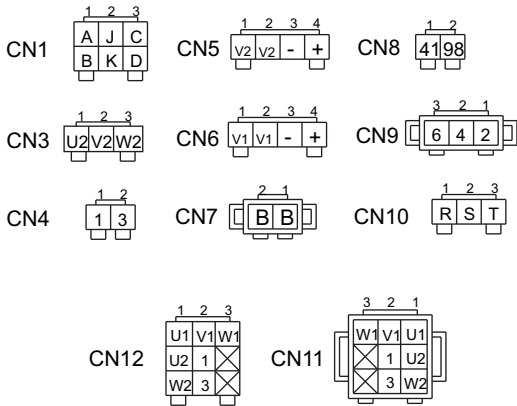

BRUSHLESS AC GENERATOR

SYMBOL	DESIGNATION
Ar	MAIN GENERATOR ARMATURE WINDING
Fg	MAIN GENERATOR FIELD WINDING
ExAr	EXCITER ARMATURE WINDING
ExFg	EXCITER FIELD WINDING
Re	RECTIFIER
AVR	AUTOMATIC VOLTAGE REGULATOR
VR	VOLTAGE REGULATOR (RHEOSTAT)
CT 1,2,3	CURRENT TRANSFORMER
AS	CHANGE-OVER SWITCH AMMETER
A	AC AMMETER
VS	CHANGE-OVER SWITCH VOLTMETER
V	AC VOLTMETER
F	FREQUENCY METER
CB1	CIRCUIT BREAKER 3P 110A
CB2,3,4	CIRCUIT BREAKER 2P 50A
CB5,6	CIRCUIT BREAKER 1P 20A
CON1,2,3	RECEPTACLE 250V 50A
CON4,5	RECEPTACLE 125V 20A X 2 (GFCI)
OC	OVER CURRENT RELAY
SW	SELECTOR SWITCH
RY1,2	RELAY UNIT

COLOR CODE			
SYM.	WIRE COLOR	SYM.	WIRE COLOR
B	BLACK	R	RED
L	BLUE	W	WHITE
BR	BROWN	Y	YELLOW
G	GREEN	LB	LIGHT BLUE
GR	GRAY	LG	LIGHT GREEN
V	VIOLET	O	ORANGE
P	PINK		

GENERATOR WIRING DIAGRAM NO. M1814000403B

ENGINE WIRING DIAGRAM (S/N 7251796 - 7254612)

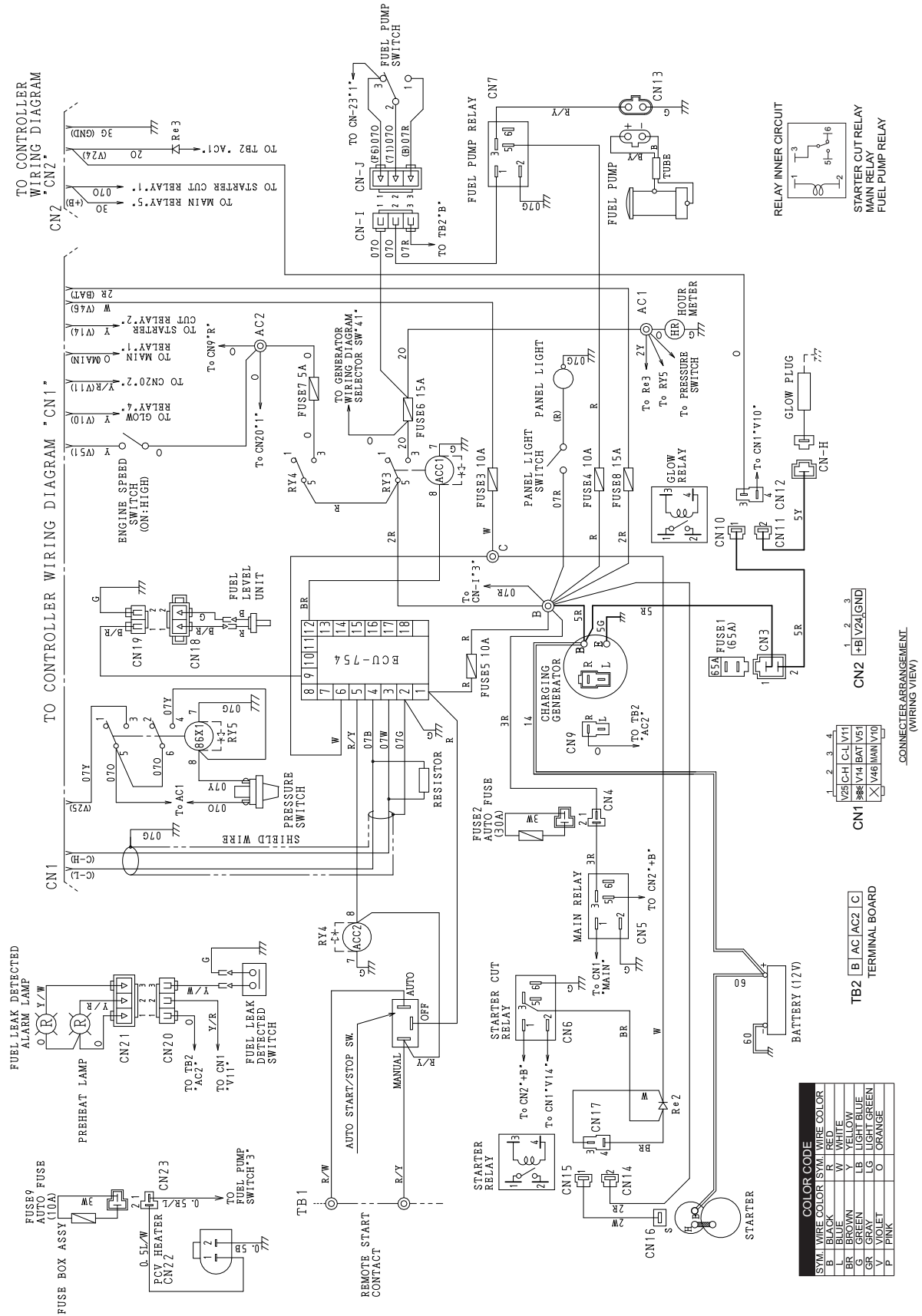

ENGINE WIRING DIAGRAM (M1814100423)

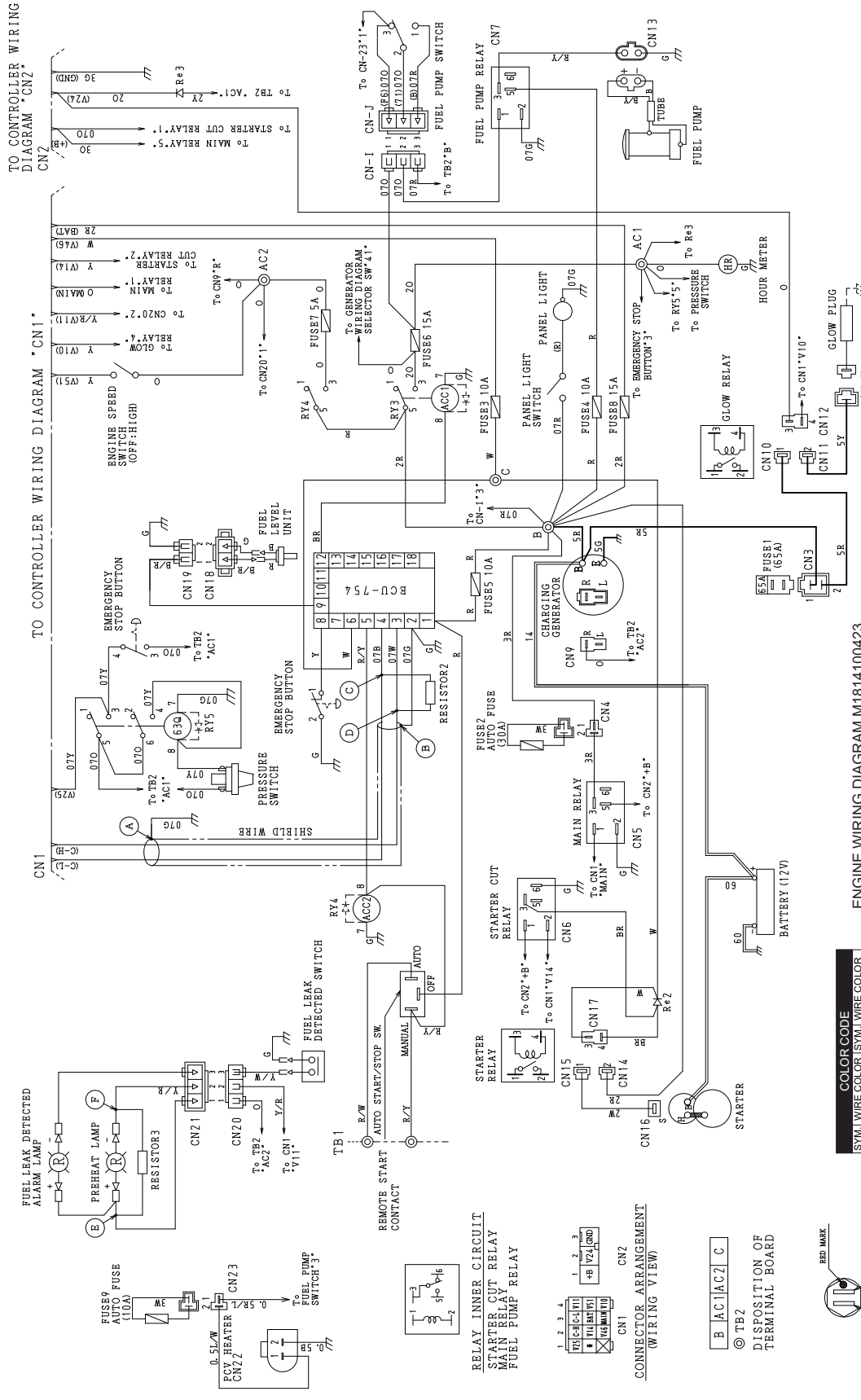

ENGINE WIRING DIAGRAM M1814100423

SYML	WIRE COLOR	SYML	WIRE COLOR
B	BLACK	Y	YELLOW
BR	BROWN	LB	LIGHT BLUE
G	GREEN	LG	LIGHT GREEN
GR	GRAY	V	VIOLET
P	PINK	O	ORANGE

SYML	WIRE COLOR	SYML	WIRE COLOR
B	BLACK	Y	YELLOW
BR	BROWN	LB	LIGHT BLUE
G	GREEN	LG	LIGHT GREEN
GR	GRAY	V	VIOLET
P	PINK	O	ORANGE

BATTERY CHARGER WIRING DIAGRAM

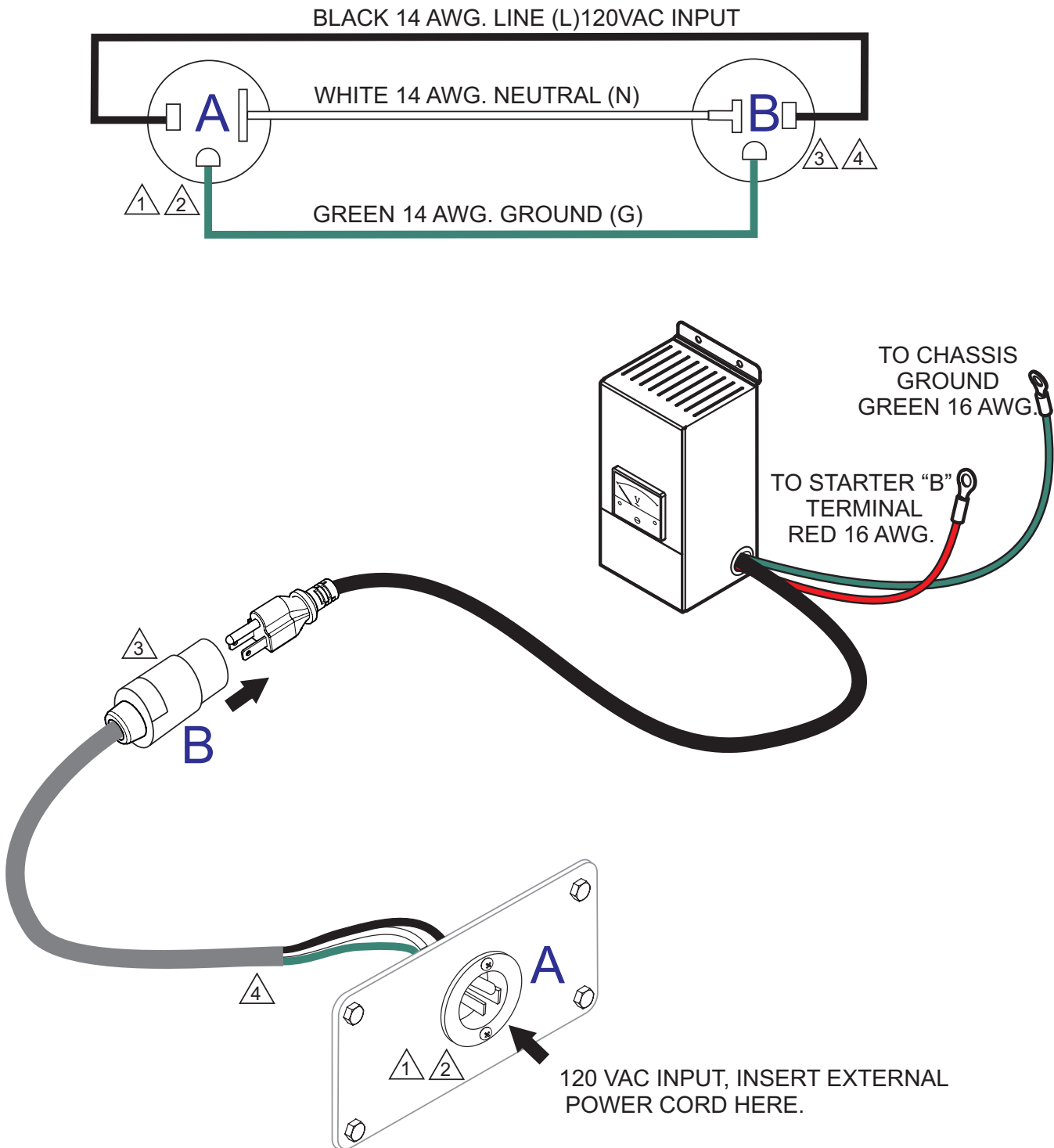

NOTES:

- △1 NEMA 5-15, 15A, 120 VAC, P/N EE6176 (HBL5278C/HUBBLE RECEPTACLE).
- △2 RECEPTACLE IS MOUNTED ON OUTPUT TERMINAL PANEL ASSY.
- △3 20 AMP, 5-20R RECEPTACLE, P/N EE6131 (HBL5369C/HUBBLE RECEPTACLE).
- △4 CORD, CAROL 3/C 14 AWG., P/N EE56557.

JACKET WATER HEATER WIRING DIAGRAM

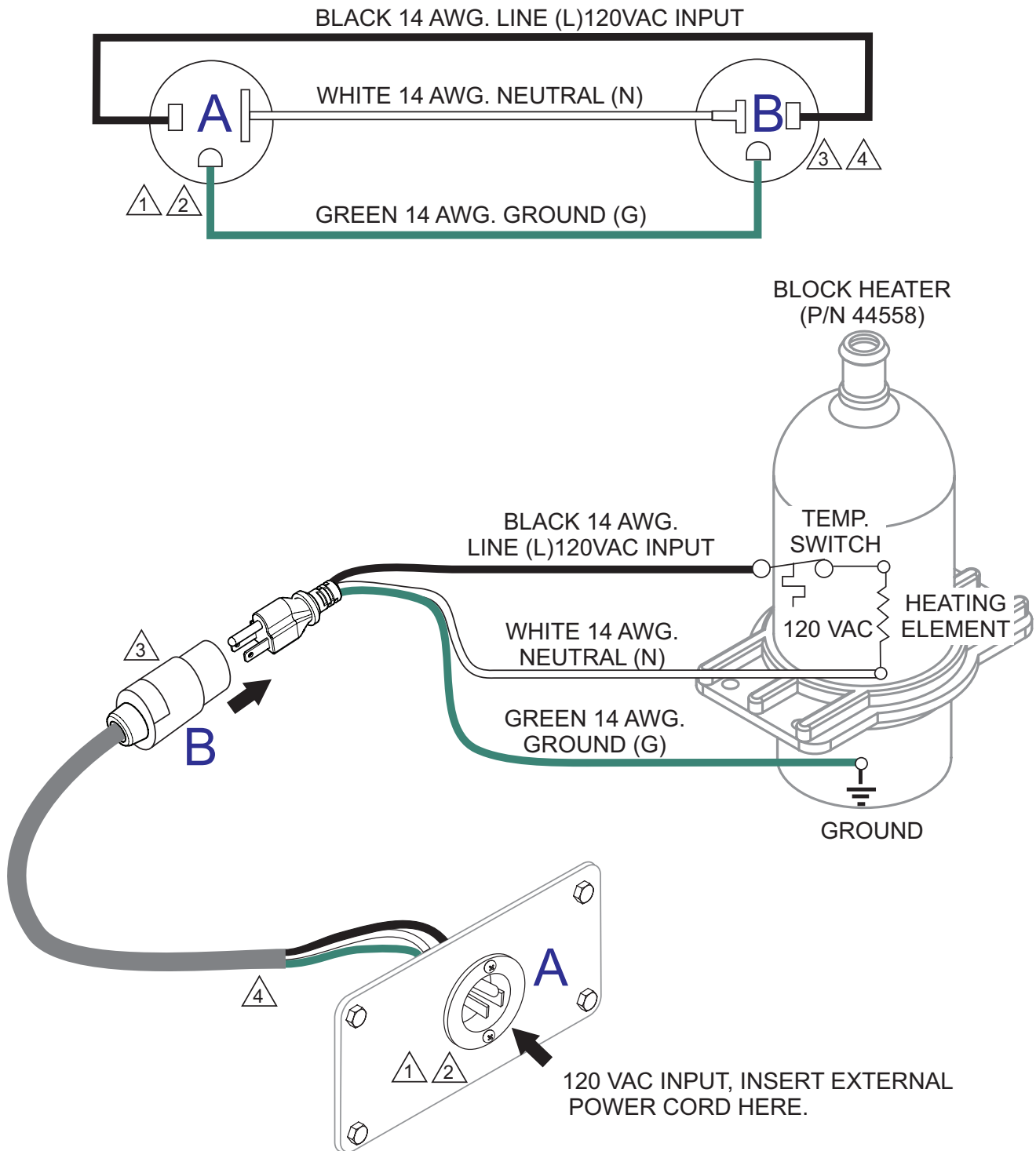

NOTES:

- ① NEMA 5-15, 15A, 120 VAC, P/N EE6176 (HBL5278C/HUBBLE RECEPTACLE).
- ② RECEPTACLE IS MOUNTED ON OUTPUT TERMINAL PANEL ASSY.
- ③ 20 AMP, 5-20R RECEPTACLE, P/N EE6131 (HBL5369C/HUBBLE RECEPTACLE).
- ④ CORD, CAROL 3/C 14 AWG., P/N EE56557.

OPERATION MANUAL

HERE'S HOW TO GET HELP

PLEASE HAVE THE MODEL AND SERIAL
NUMBER ON-HAND WHEN CALLING

UNITED STATES

Multiquip Inc.

(310) 537- 3700
6141 Katella Avenue Suite 200
Cypress, CA 90630
E-MAIL: mq@multiquip.com
WEBSITE: www.multiquip.com

CANADA

Multiquip

(450) 625-2244
4110 Industriel Boul.
Laval, Quebec, Canada H7L 6V3
E-MAIL: infocanada@multiquip.com

UNITED KINGDOM

Multiquip (UK) Limited Head Office

0161 339 2223
Unit 2, Northpoint Industrial Estate,
Globe Lane,
Dukinfield, Cheshire SK16 4UJ
E-MAIL: sales@multiquip.co.uk

© COPYRIGHT 2021, MULTIQUIP INC.

Multiquip Inc, the MQ logo and the MQ Power logo are registered trademarks of Multiquip Inc. and may not be used, reproduced, or altered without written permission. All other trademarks are the property of their respective owners and used with permission.

This manual MUST accompany the equipment at all times. This manual is considered a permanent part of the equipment and should remain with the unit if resold.

The information and specifications included in this publication were in effect at the time of approval for printing. Illustrations, descriptions, references and technical data contained in this manual are for guidance only and may not be considered as binding. Multiquip Inc. reserves the right to discontinue or change specifications, design or the information published in this publication at any time without notice and without incurring any obligations.

Manufactured for
MQ Power Inc.
by
DENYO MANUFACTURING CO.

