

MODELS | VR-642D VR-843D



Operating Manual

Variable Reach Telehandlers

923630AE-A October 2011



This manual is based on Serial Number(s):

VR 642D 87 000 008 & Below
VR 843D 87 000 064 & Below

Please refer to the website (www.skyjack.com) for older Serial Numbers.

Skyjack Service Center 3451 Swenson Ave. St. Charles, Illinois, 60174 USA

Phone: 630-262-0005

Toll Free: 1-800-275-9522

Fax: 630-262-0006

Email: service@skyjack.com

Parts (North America)

Toll Free: 1-800-965-4626

Toll Free Fax: 1-888-782-4825

Email: parts@skyjack.com

Parts & Service (Europe) Unit 1 Maes Y Clawdd, Maesbury Rosd Industrial Estate

Oswestry, Shropshire, SY10 8NN UK

Phone: +44-1691-676-235

Fax: +44-1691-676-238

Email: info@skyjackeurope.co.uk

Skyjack Asia Pacific

Singapore

Phone: +65-6449-3710

Fax: +65-6449-7690

Email: skyjack@singnet.com.sg

The Safety Alert Symbol identifies important safety messages on telehandler, safety signs in manuals or elsewhere. When you see this symbol, be alert to the possibility of personal injury or death. Follow the instructions in the safety message.



This Safety Alert Symbol means attention!

Become alert! Your safety is involved.



DANGER

DANGER indicates an imminently hazardous situation which, if not avoided, will result in death or serious injury.



WARNING

WARNING indicates a potentially hazardous situation which, if not avoided, could result in death or serious injury.



CAUTION

CAUTION indicates a potentially hazardous situation which, if not avoided, may result in minor or moderate injury. It may also be used to alert against unsafe practices.

IMPORTANT

IMPORTANT indicates a procedure essential for safe operation and which, if not followed, may result in a malfunction or damage to the telehandler.

Table of Contents

Section 1 - About Your Telehandler

Read and Heed

Telehandler Definition	7
Purpose of Equipment	7
Use of Equipment	7
Manual.....	7
Operator	7
Service Policy and Warranty	7
Optional Accessories	7
Scope of this Manual	7

Safety Rules

Operator Safety Reminders	8
Electrocution Hazard	9
Safety Precautions	10

Section 2 - Operation

2.1	General	17
2.1-1	Operator Qualifications.....	17
2.1-2	Operator's Responsibility for Maintenance	17
2.1-3	Maintenance and Inspection Schedule.....	17
2.1-4	Owner's Inspections	17
2.2	Major Components.....	18
2.3	Major Assemblies	19
2.3-1	Frame	19
2.3-2	Cab	19
2.3-3	Boom Assembly.....	19
2.3-4	Attachment.....	19
2.4	Serial Number Nameplate	19
2.5	Component Identification	20
2.5-1	Operator's Cab	20
	Seat.....	20
	Manual Storage Box	20
2.5-2	Operator's Cab Controls	21
2.5-3	Boom Safety Stop.....	24
2.6	Operator's Responsibility	25
2.7	Visual & Daily Maintenance Inspections	27
2.7-1	Labels.....	27
2.7-2	Electrical	27
2.7-3	Mirrors.....	27
2.7-4	Hydraulic.....	27
2.7-5	Cylinders.....	28
2.7-6	Frame.....	28
2.7-7	Engine Compartment	30
2.7-8	Transmission.....	31
2.7-9	Boom	31
2.7-10	Lifting Attachment.....	32
2.7-11	Grease Fittings.....	32
2.7-12	Operator's Cab	33
2.8	Function Tests.....	36
2.8-1	Operator's Cab Controls	36

Table of Contents

Section 2 - Operation (Continued)

2.9	Start Operation	43
2.9-1	Starting the Engine	43
2.9-2	Driving the Telehandler	44
2.9-3	Driving on Slopes	44
2.9-4	Steering the Telehandler.....	45
2.9-5	Leveling the Telehandler.....	45
2.9-6	Raising or Lowering Boom	45
2.9-7	Extending or Retracting Boom	46
2.9-8	Handling Loads	46
2.9-9	Parking and Shutting-down the Telehandler	47
2.10	Refueling Procedure (Diesel Fuel Only).....	47
2.11	Use of the Capacity Charts	48
2.11-1	Examples on Reading the Capacity Chart	49
2.12	Attachments Installation and Operation.....	50
2.12-1	Installing Attachments Using the Quick Attach Feature.....	50
2.12-2	Removing Attachments Using the Quick Attach Feature.....	50
2.12-3	Handling Loads at Ground Level	51
2.12-4	Handling Loads at Variable Heights	52
2.12-5	Adjusting Forks.....	53
2.12-6	Changing Forks	53
2.13	Optional Attachments.....	54
2.13-1	Swing Carriage	54
2.13-2	Bucket Loader	54
2.13-3	Scrap Grapple Bucket	55
2.13-4	Truss Boom.....	55
2.13-5	Side Tilt Carriage	56
2.13-6	Pintle Hook	56
2.14	Loading and Transporting	57
2.14-1	Loading and Tie-down.....	57
2.14-2	Towing the Telehandler.....	58
2.15	Tables.....	60
2.16	Labels	66

List of Tables

2.1	Standard Features.....	60
2.2	Specifications and Features.....	61
2.3	Tire/Wheel Specifications.....	62
2.4	Recommended Fluids/Lubrication.....	63
2.5	Maintenance and Inspection Schedule	64
2.6	Operator's Checklist.....	65

SKYJACK is continuously improving and expanding product features on its equipment, therefore, specifications and dimensions are subject to change without notice.

Telehandler Definition

A material handler designed primarily as a fork truck with a pivoting telescopic boom which enables it to pick and place loads at distances as well as various lift heights.

Purpose of Equipment

The SKYJACK telehandlers are designed to lift, handle and transport agricultural or industrial products by means of specific attachments.

Use of Equipment

The telehandler is a highly maneuverable, mobile work station. Lifting, handling and driving must be on a flat, level, compacted surface. It can be driven over uneven terrain only when the boom is fully lowered.

Manual

The operating manual is considered a fundamental part of the telehandler. It is a very important way to communicate necessary safety information to users and operators. A complete and legible copy of this manual must be kept in the provided weather-resistant storage compartment on the telehandler at all times.

Operator

The operator must read and completely understand both this operating manual and the safety panel label located on the telehandler and all other warnings in this manual and on the telehandler. Compare the labels on the telehandler with the labels found within this manual. If any labels are damaged or missing, replace them immediately.

Service Policy and Warranty

SKYJACK warrants each new VR series telehandler to be free of defective parts and workmanship for the first 12 months or 2000 hours, whichever occurs first. Any defective part will be replaced or repaired by your local SKYJACK dealer at no charge for parts or labor. Contact SKYJACK Service Department for warranty statement extensions or exclusions.

Optional Accessories

The SKYJACK telehandler is designed to accept a variety of optional accessories. These are listed under “Attachments Installation and Operation” in Section 2. Operating instructions for these options (if equipped) are located in Section 2 of this manual.

For non-standard components or systems, contact the SKYJACK Service Department at

☎ : 800 275-9522

📠 : 630 262-0006

Include the model and serial number for each applicable telehandler.

Scope of this Manual

a. **This manual applies** to the ANSI/ASME/ITSDF and CSA versions of the VR-642D and VR-843D telehandlers.

- **Equipment identified** with “ANSI” meets the ASME/ANSI B56.6 standard.
- **Equipment identified** with “CSA” meets the CSA B335-04 standard.

b. **CSA (Canada)**

Operators are required to conform to national, territorial/provincial and local health and safety regulations applicable to the operation of this telehandler.

c. **ANSI (United States)**

Operators are required by the current ANSI standards are required to conform to national, territorial/provincial and local health and safety regulations applicable to the operation of this telehandler.



Failure to comply with your required responsibilities in the use and operation of the telehandler could result in death or serious injury!

Operator Safety Reminders

A study conducted by St. Paul Travelers showed that most accidents are caused by the failure of the operator to follow simple and fundamental safety rules and precautions.

You, as a careful operator, are the best insurance against an accident. Therefore, proper usage of this telehandler is mandatory. The following pages of this manual should be read and understood completely before operating the telehandler.

Common sense dictates the use of protective clothing when working on or near machinery. Use appropriate safety devices to protect your eyes, ears, hands, feet and body.

Some attachments may not be approved for use with certain telehandler models. Use only approved attachments.

Any modifications from the original design are strictly forbidden without written permission from Skyjack.

Electrocution Hazard

This telehandler is not electrically insulated. Use extreme caution around high-voltage overhead power lines and maintain a Minimum Safe Approach Distance (MSAD) of 10 feet from source of power. Adhere to all federal/national, state/provincial, or local safety regulations for your own protection.

No part of telehandler or payload should be brought closer to any energized overhead electrical conductor with nominal phase voltage rating as specified below:

Voltage	Distance
750 to 150,000	10 feet
150,000 to 250,000	15 feet
250,000	20 feet

**DANGER**

Never approach any power line with any part of telehandler. Use extreme caution; serious injury or death can result with contact from any power line.

IMPORTANT

Always assume electrical power sources and overhead lines are energized.

**DO NOT USE TELEHANDLER AS A GROUND FOR WELDING.
DO NOT OPERATE TELEHANDLER DURING LIGHTNING OR STORMS.**

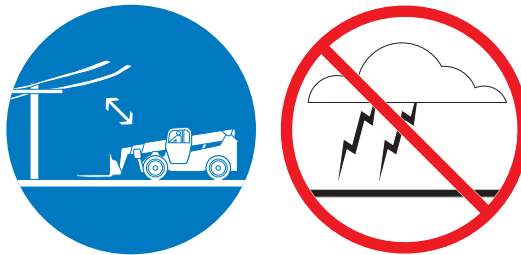

Safety Precautions

Know and understand all safety precautions before going on to the next section.



WARNING

DO NOT operate this telehandler without proper authorization and training. Failure to avoid this hazard could result in death or serious injury.



WARNING

Failure to heed the following safety precautions could result in tip over, falling, crushing, or other hazards leading to death or serious injury.

- **MAKE SURE** all DANGER, WARNING, CAUTION and INSTRUCTIONAL DECALS are in place and can be read. Clean or replace decals as required.
- **KNOW** all national, state/provincial and local rules which apply to your telehandler and jobsite.
- **WEAR** all the protective clothing and personal safety devices issued to you or called for by job conditions.

- **DO NOT** wear loose clothing, dangling neckties, scarves, rings, wristwatches or other jewelry while operating this telehandler.



- **DO NOT** climb on this vehicle for any reason.



- **DO NOT** stand on forks. Use of forks to lift personnel is strictly prohibited.



- **DO NOT** use telehandler as a man lift or equip this telehandler with a personnel work platform.



- **DO NOT** use forklift attachment as a crane.



- **DO NOT** elevate the boom in windy or gusty conditions.



- **DO NOT** drive with boom elevated.



- **DO NOT** operate on surfaces not capable of holding the weight of the telehandler; including the rated load (e.g., covers, drains, and trenches).



- **DO NOT** maneuver a load while moving. This greatly increases the chance of spills and injury.



Safety Precautions (Continued)

Know and understand all safety precautions before going on to the next section.

- **DO NOT** exceed the maximum safe operating slope.

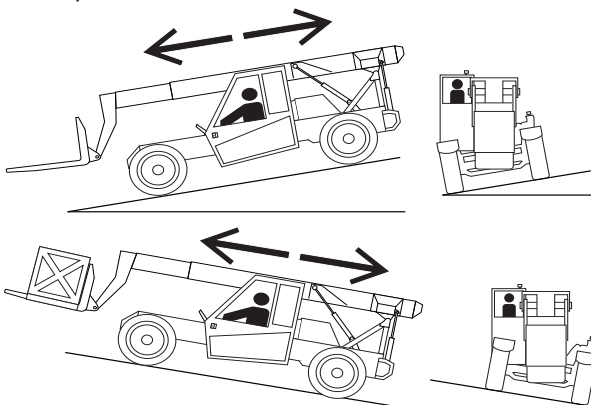

- **DO NOT** lower the boom unless the area below is clear of personnel and obstructions.



- **DO NOT** elevate the boom while the telehandler is on a truck, forklift or other device or vehicle.



- **DO NOT** use frame leveling when boom is elevated.



- **ENSURE** that there are no personnel or obstructions in the path of travel, including blind spots.

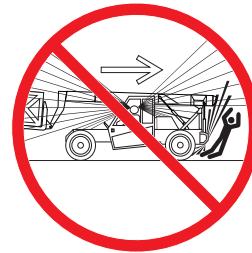

- **DO NOT** use the frame-leveling mechanism to compensate for swinging loads.

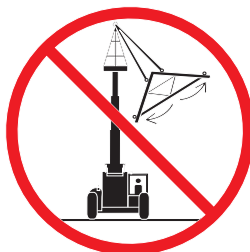

- **BE AWARE** of crushing hazards. Keep head, arms, hands, legs and all other body parts inside the operator's cab at all times.



DO NOT enter the danger area under or around the boom when forks are off the ground or while engine is running.



- **AVOID** jerks and sudden stops.



- **AVOID** entanglement with ropes, cords or hoses.



Safety Precautions (Continued)

Know and understand all safety precautions before going on to the next section.

- **BE AWARE** of all obstructions while traveling. Check for clearance before traveling between obstacles.

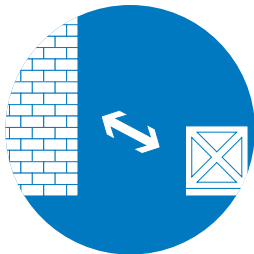

- **USE CAUTION** when boom is fully extended. The further out the boom is extended, the less load telehandler can support.



- **USE CAUTION** when placing loads at high elevations and on downhill slopes.



- **WALK AROUND** the telehandler before operation and check for any visible signs of damage or malfunction.

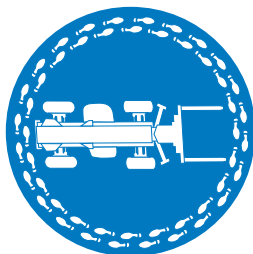

- **ALWAYS** maintain three points of contact when entering vehicle. Use provided hand-holds and steps only.

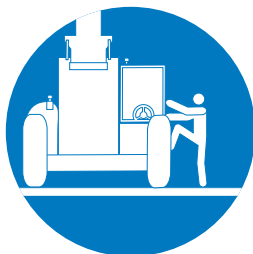

- **ALWAYS** wear your seat belt when operating this vehicle.



- **KNOW** the weight of the load you are transporting. Never lift more than the lifting capacity at any given extension or elevation of the boom as listed on the load charts.



- **CHECK** for cracks and signs of stress.



- **TRAVEL SLOWLY** over rough terrain.



- **If operation in areas with holes or drop-offs is absolutely necessary**, ensure that all 4 wheels or stabilizers (if equipped) have contact with firm surface. Then level the frame. Once frame is level the boom can be elevated. After elevation, the drive function must not be activated.



Safety Precautions (Continued)

Know and understand all safety precautions before going on to the next section.

- **DRIVE DOWNHILL UNLOADED.** Without a load, the back end is the heaviest part of the telehandler. Driving downhill decreases potential for tipover.



- **SECURE** loose loads with chains or straps to decrease potential of spills or injury to others.

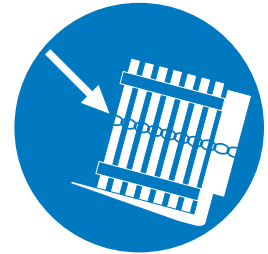

- **DRIVE UPHILL LOADED.** When holding a load, driving uphill decreases potential for load to slip out.

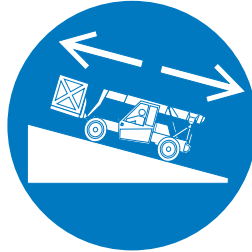

- **TETHER LOADS** that may swing, keeping them close to the ground. Provide ample clearance for personnel to guide the load safely.



- **LEVEL FRAME ON SLOPES** before elevating boom

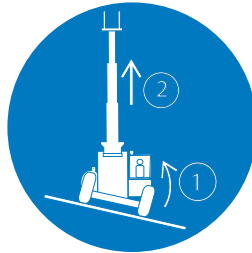

- **BE AWARE** of the telehandler's travel envelope, especially when turning. Keep sufficient clearance at all times between the telehandler and any obstacles or people.

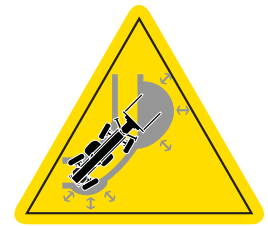

- **WHEN TRANSPORTING LOADS** fully retract the boom, keep the load low to the ground and forks tilted back slightly. This is the most stable position possible for the vehicle.



- **KEEP OTHERS AWAY** at all times during operation.

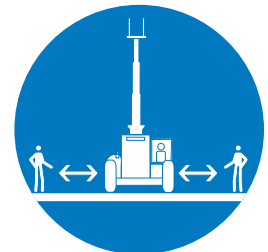

- **KEEP** forks close to the ground when in motion to increase telehandler stability and decrease potential for injury to others. When fully stopped, lower forks completely to the ground.

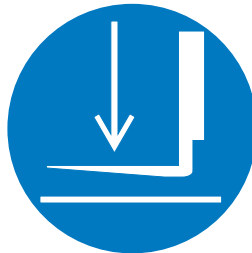

- **CHECK** lights for proper function before operating.



- **TILT** forks backward slightly when traveling to decrease potential of load slipping off.

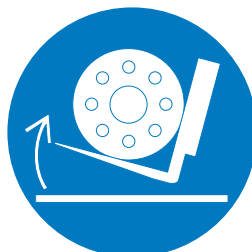

- **ENSURE ALL** tires are in good condition and lug nuts are properly tightened.



Safety Precautions (Continued)

Know and understand all safety precautions before going on to the next section.

- **DO NOT** alter or disable safety devices.
- **DO NOT** burn or drill holes in forks. Modifying any part of telehandler or attachment affects its capacity and/or stability.
- **DO NOT** try to start the telehandler by pushing or towing. Such operation may cause severe damage to the transmission - Refer to Section 2.
- **IF DRIVING ON ROADS OPEN TO PUBLIC TRAFFIC** respect the local regulations.
- **THE OPERATOR'S CAB** provides a falling object protection structure (FOPS) and a rollover protection structure (ROPS). **Do not make any modification to this structure.** If damaged, the cab cannot be repaired. It must be replaced.
- **STUNT** driving and horseplay are prohibited.
- **ALWAYS USE FRONT** steering when traveling at high speeds; i.e. on highways and public roads.
- **ALWAYS USE FRONT** steering when traveling at high speeds.
- **DO NOT** change steering mode while the telehandler is traveling. Change the steering mode only when telehandler is stopped.
- **ALWAYS** look in the direction of travel. Reduce speed and be especially careful when traveling in reverse and/or turning. Bring the telehandler to a complete stop before changing the direction of travel.
- **STAY CLEAR** of pinch points and rotating parts on the material handler. Getting caught in a pinch point or a moving part can cause serious injury or death. Before performing any maintenance on telehandler, follow the shutdown procedure on Section 2.9-9.
- **DO NOT** position the telehandler against another object to steady the load.
- **SHUT DOWN** by positioning the telehandler in a safe location. Lower boom to ground, apply the parking brake, move all controls to 'neutral' and allow engine to idle for 3 to 5 minutes. Stop engine and remove ignition key to prevent unauthorized use. Block wheels.

**WARNING**

Always engage park brake and shut off engine before leaving the operator's cab.

Safety Precautions (Continued)

Know and understand all safety precautions before going on to the next section.

**WARNING**

Entering and exiting the telehandler should only be done using the three points of contact.

- Use only equipped access openings.
- Enter and exit only when the telehandler is in the fully retracted position.
- Do use three points of contact to enter and exit the cab.
- Three points of contact means that two hands and one foot or one hand and two feet are in contact with the telehandler or the ground at all times during entering and exiting.

**WARNING**

Operator should not use any telehandler that:

- does not appear to be working properly.
- has been damaged or appears to have worn or missing parts.
- has alterations or modifications not approved by the manufacturer.
- has safety devices which have been altered or disabled.
- has been tagged or locked out for non-use or repair.
- bears an unapproved attachment.

Failure to avoid these hazards could result in death or serious injury.

Jobsite Inspection

- Do not use in hazardous locations.
- Perform a thorough jobsite inspection prior to operating the telehandler, to identify potential hazards in your work area.
- Be aware of moving equipment in the area. Take appropriate actions to avoid collision.

2.0 Operation

This section provides the necessary information needed to operate the telehandler. It is important that the user reads and understands this section before operating the telehandler.

2.1 General

In order for this telehandler to be in good working condition, it is important that the operator meets the necessary qualifications and follows the maintenance and inspection schedule referred to in this section.

2.1-1 Operator Qualifications

- Only trained and authorized personnel shall be permitted to operate the telehandler.
- Safe use of this telehandler requires the operator to understand the limitations and warnings, operating procedures and operator's responsibility for maintenance. Accordingly, the operator must understand and be familiar with this operating manual, its warnings and instructions, and all warnings and instructions on the telehandler.
- The operator must be familiar with employer's work rules and related government regulations and be able to demonstrate the ability to understand and operate this make and model of telehandler in the presence of a qualified person.



WARNING

DO NOT operate this telehandler without proper authorization and training. Failure to avoid this hazard could result in death or serious injury.

2.1-2 Operator's Responsibility for Maintenance



WARNING

Maintenance must be performed by trained and competent personnel who are familiar with mechanical procedures.

Death or serious injury could result from the use of a telehandler that is not properly maintained or kept in good working condition.

- The operator must be sure that the telehandler has been properly maintained and inspected before using it.
- The operator must perform all the daily inspections and function tests found in Table 2.5, even if the operator is not directly responsible for the maintenance of this telehandler.

2.1-3 Maintenance and Inspection Schedule

- The inspection points covered in Table 2.5 indicate the areas of the telehandler to be maintained or inspected and at what intervals the maintenance and inspections are to be performed.
- The actual operating environment of the telehandler may affect the maintenance schedule.



WARNING

Use original or manufacturer-approved parts and components for the telehandler.

2.1-4 Owner's Inspections

It is the responsibility of the owner and/or operator to arrange daily, quarterly (or 250 hours) and annual inspections of the telehandler. Refer to Table 2.5 for recommended maintenance and inspection areas and intervals.

2.2 Major Components

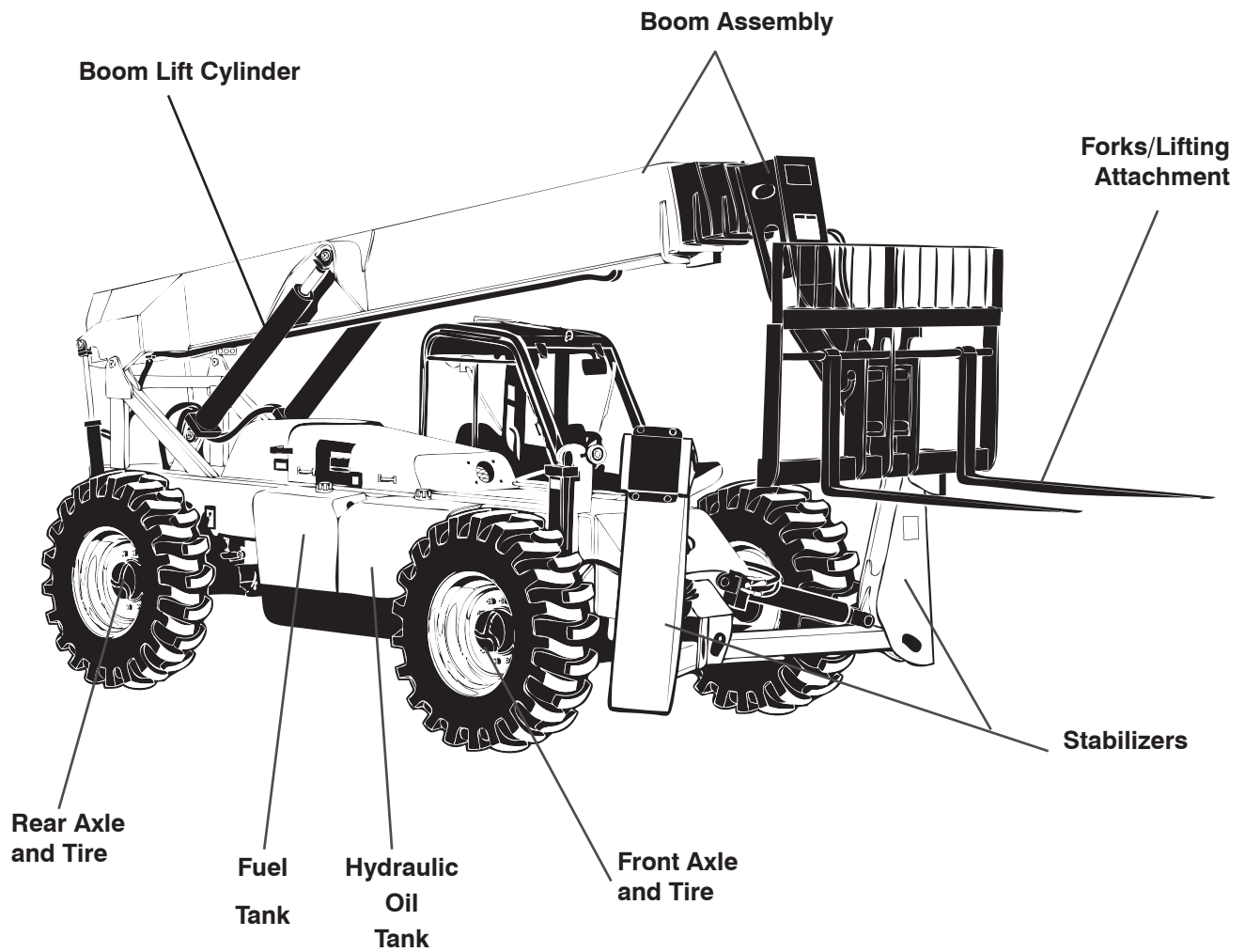

VR-Series Telehandler

2.3 Major Assemblies

The telehandler consists of four major assemblies: the frame, boom assembly, attachment and cab.

2.3-1 Frame

The frame is a one-piece weldment that supports the boom assembly. The parking brake is integral with the axle and is located in the front axle.

2.3-2 Cab

The cab is the safety structure enclosing the operator. It also furnishes the controls of the telehandler.

2.3-3 Boom Assembly

The boom is mounted on the frame and consists of three telescoping boom section(s). The boom assembly consists of section 1 boom assembly, section 2 boom assembly, and section 3 boom assembly. The jib assembly is welded to the end of section 3 boom assembly. The telehandler is equipped with a carriage tilt cylinder, which is mounted to the inside of the jib. The quick attachment apron is mounted to the jib and is supported by the tilt cylinders.

2.3-4 Attachment

The attachment is a material-handling device attached to the boom. The standard attachment is a fork attachment. Refer to Section 2.13 for various attachments. Optional attachments include side-tilt carriage, drywall handler carriage, scrap grapple bucket, & truss boom attachments.

2.4 Serial Number Nameplate

The serial number nameplate, located at the front left side of telehandler lists the following:

- Model number
- Serial number
- Maximum capacity
- Maximum lift height
- Maximum machine weight with out attachment
- Original supplied attachments
- Year of manufacture
- Voltage

2.5 Component Identification

The following descriptions are for identification, explanation and locating purposes only.

2.5-1 Operator's Cab

The operator's cab allows vision from all sides and is equipped with a rollover and falling object protective structure.



WARNING

The operator's cab provides a falling object protection structure (FOPS) and a rollover protection structure (ROPS). Do not make any modification to this structure. If damaged, the cab cannot be repaired. It must be replaced.

A fully-enclosed cab with windows and door is available as an option. Included in this option is the windshield wiper, interior light and air heater/defroster. Air conditioner is also available as an option for fully enclosed cab.

The operator's seat is equipped with a seat belt (2). Use this seat belt at all times when operating telehandler.

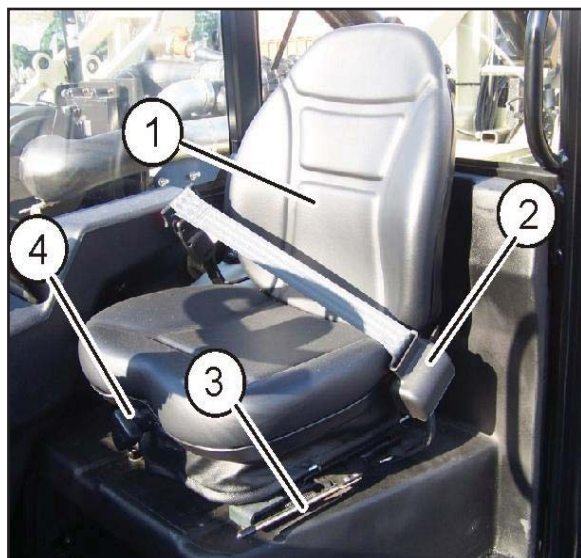

Figure 2-1. Telehandler Seat

Seat

The telehandler seat (1) is equipped with devices which allow for the adjustment of seat ride smoothness and distance from the controls. Adjust the seat (3) so that foot pedals, steering wheel and instrument panel controls are within easy reach of the operator.

The ride control (If equipped) (4) is located at the front of the seat and is operated by means of a rotary knob. Clockwise rotation decreases the firmness while counterclockwise rotation increases the firmness.

The fore and aft lock lever (3) is located on the left side of the seat. Pushing the lever to the left unlocks the seat, allowing fore and aft adjustment.



WARNING

The seat belt must be worn at all times.

Manual Storage Box

This weather-resistant box (1) is mounted at the back of the operator's seat. It contains operating manual and other important documentation. The operating manual for this make and model of telehandler must remain with the telehandler and should be stored in this box. (Manual storage box may not be exactly as shown).

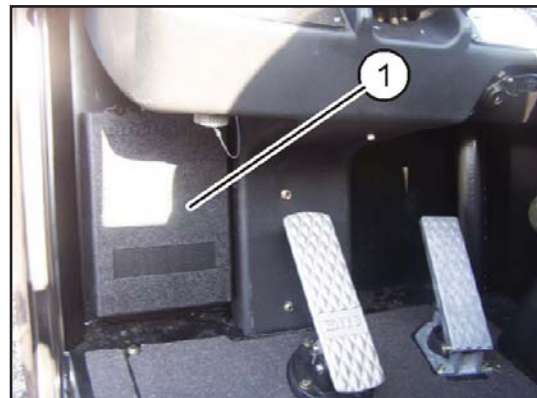
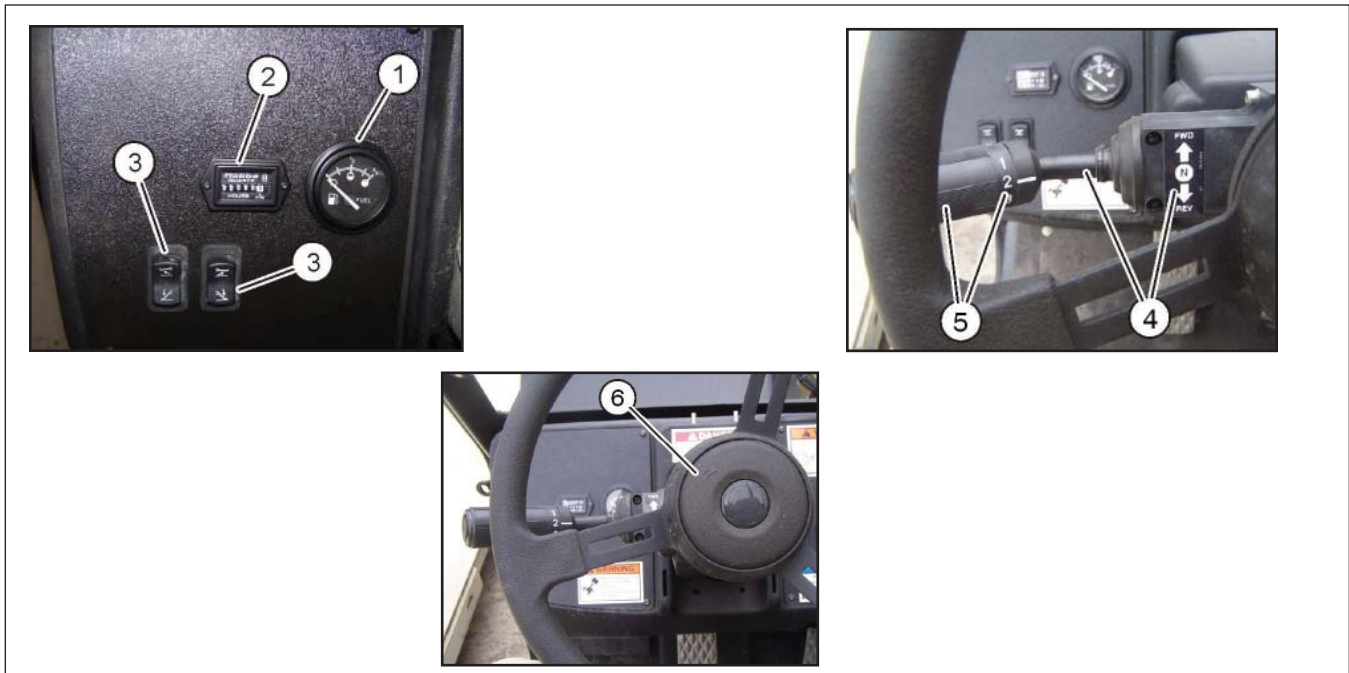



Figure 2-2. Manual Storage Box

2.5-2 Operator's Cab Controls



1. **Fuel Gauge** - Indicates the amount of fuel in the fuel tank. Fill the tank with #2 filtered diesel fuel when the indicator needle moves below the 1/4 tank mark.
2. **Hourmeter** - This gauge records accumulated operating time of the telehandler.
3. **Left and Right Stabilizer Switches** - These are nonlatching, rocker-type switches that control the right and left stabilizers.

Pressing and holding the upper portion of the switches “” raises the stabilizers.

Pressing and holding the lower portion of the switches “” lowers the stabilizers.
4. **Direction Control Lever** - This lever allows forward or reverse travel. The center position is neutral. To select forward travel, lift from lock position and move the direction control lever to the “FWD” forward position; for reverse travel move lever to “REV”.
5. **Transmission Range Selector** - Located on the direction control lever. The transmission has three speeds in either direction. Rotate handle grip to select speed range.
6. **Steering Wheel and Horn Button** - Turn the steering wheel to the left or right to steer the telehandler in the corresponding direction. Three steering modes are available (refer to Section 2.9-4).

The horn button activates the horn. The horn alerts personnel to the approach of the telehandler or to a change of direction.

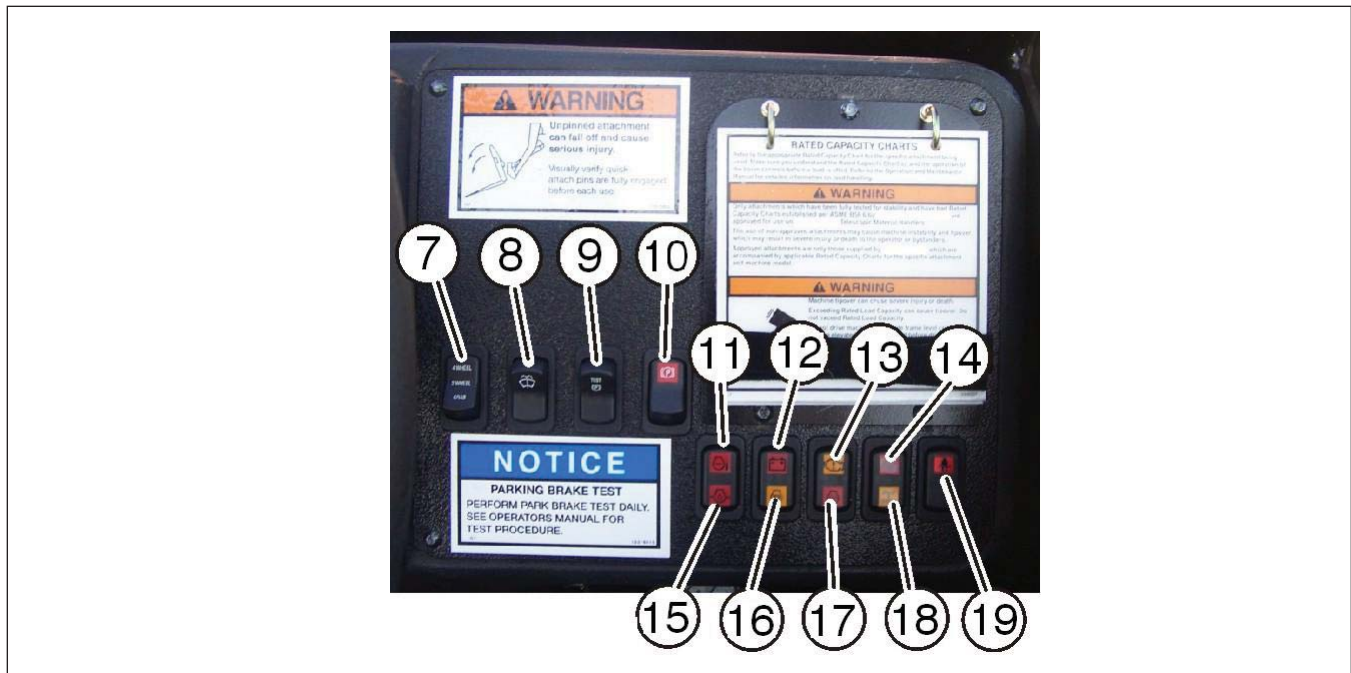

7. **Steer Mode Switch** - This switch has three positions to allow selection of round steer, front steer and crab steer.
8. **Windshield Washer Switch (if equipped)** - This switch activates the pump for the windshield washer. Press and hold the switch to activate.
9. **Park Brake Test Switch** - The park brake test switch is used to test the operation of the park brake.
10. **Park Brake Switch** - This switch controls the spring applied, hydraulically released parking brake. Apply the parking brake by pressing the switch at the end marked (P) when the engine is running. When the brake is "ON", the parking brake red warning light (switch) illuminates.
11. **Water Temperature Indicator** - This red light indicator illuminates when the engine coolant temperature is not within the normal operating temperature range.
12. **Battery Indicator** - Indicates the condition of the batter. The indicator illuminates when the battery is faulty.
13. **Engine Warning Indicator** - This amber light indicator illuminates when the ignition key is in the "ON" position before starting, indicating a malfunction that is not service-related or does not cause damage to the engine.
14. **Transmission Coolant Temperature Indicator** - This red light indicator illuminates when the transmission coolant temperature is not within the normal operating range.
15. **Engine Oil Temperature Indicator** - This red light indicator illuminates when the engine oil temperature is not within the normal operating range.
16. **Engine Preheat Indicator** - This amber light illuminates while the grid heater is heating. The indicator goes out when the grid heater temperature is high enough to assist in starting the engine.
17. **Engine Stop Indicator** - This red light illuminates when the ignition key is in the "ON" position before starting, indicating a problem that can damage the engine.
18. **Rear Axle Stabilization Indicator** - This amber light illuminates while the rear axle stabilization system is running. When engaged, this system automatically locks the rear axle to the frame through a cylinder.

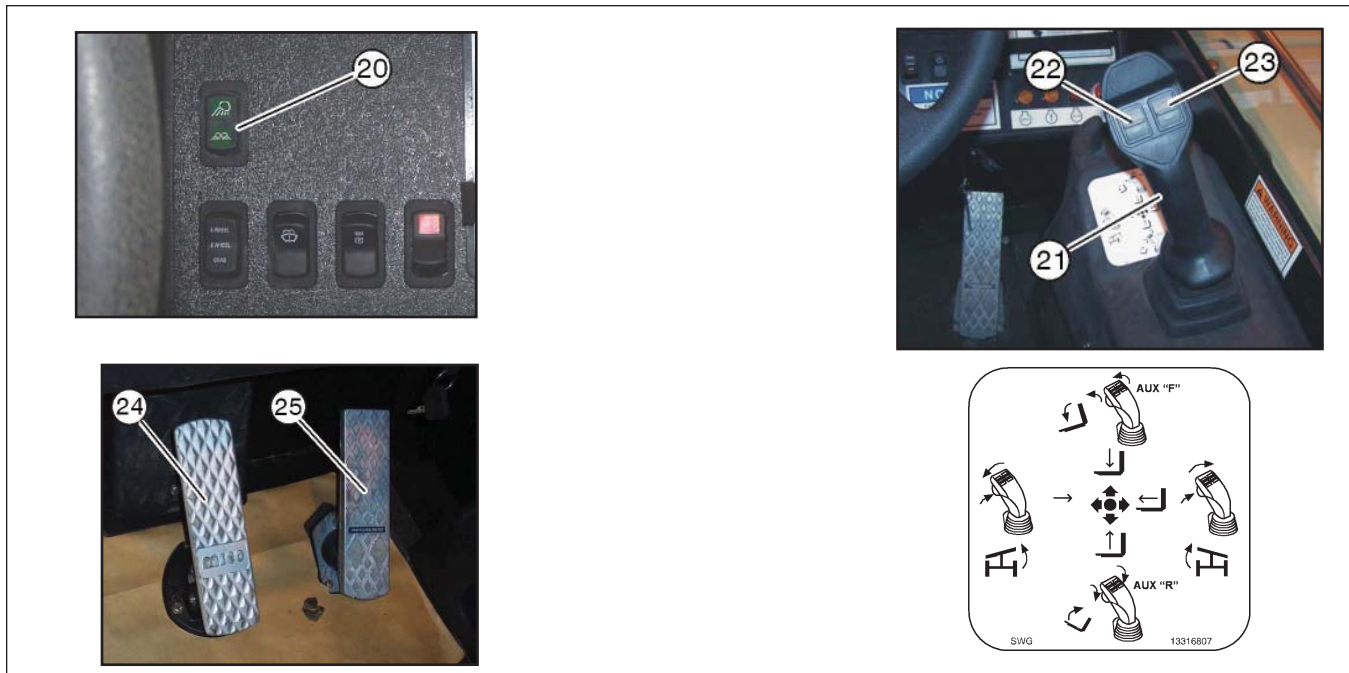

19. Seat Belt Indicator - The seat belt indicator illuminates as long as the seatbelt is not buckled. Once the operator buckles the seatbelt, the indicator goes out.

20. Boom Light Switch (if equipped) - The boom light switch controls the light at the end of the boom.

21. Single joystick control - This dual-axis lever is a multi-functional control allowing the operator to control boom operation (extend or retract and up or down), frame and boom leveling, fork tilt, and auxiliary functions such as fork side tilt or swing fork. The lever returns it to neutral when released.

To raise the boom, move the joystick backward.
To lower the boom, move the joystick forward.

To extend the boom, move the joystick to the right. To retract the boom, move the joystick to the left.

22. Attachment Tilt Switch - This switch controls the fork tilt.

To tilt attachment forward, depress and hold the left switch up. To tilt attachment backward, press and hold the left switch down.

23. Auxiliary Control Switch (if available) - This switch controls the optional attachment.

Press and hold the switch up to operate an "OUT" or "LEFT" direction function. Press and hold the switch down to operate an "IN" or "RIGHT" direction function.

Pressing and holding the pushbutton (located on the bottom of the control) activates the frame level feature while moving the single joystick control to the left to tilt (lower) the left side of the frame or to the right to tilt (lower) the right side of the frame.

24. Service Brake Pedal - The service brake is foot operated and is used to decrease speed or stop. The transmission remains engaged.

25. Accelerator Pedal - Press pedal to increase speed and release pedal to decrease speed.



26. Ignition Switch - This is a three-position switch.

When in “○” off position, it turns the engine off and key can be removed. When in “|” on position, it provides power to ignition and auxiliary circuits. When in “| |” start position, it starts the engine; when released, key returns to “|” on position.

27. Level Indicator - Located on the upper cross member of the overhead guard. When the ball is centred in the indicator, this indicates that telehandler frame is level with the ground.

28. Capacity Charts - This set of charts indicates operating limits specific to a telehandler model and attachments. Refer to Section 2.11.

29. 12 Volt Power Port - A convenient 12 Volt power port is on the side of the joystick control console near the right-hand seat belt latch.

2.5-3 Boom Safety Stop

The telehandler is equipped with a boom safety stop (item 1) to be used whenever work is performed under a raised boom. It must be placed over one of the boom lift cylinders and the boom lowered onto the stop. The stop is stowed behind the hood on the deck plate at the rear of the telehandler.



Figure 2-3. Boom Safety Stop

2.6 Operator's Responsibility

It is the responsibility of the operator, prior to each work shift, to perform the following:

1. Visual and Daily Maintenance Inspections

- Designed to discover any damage of components before the telehandler is put into service.
- Completed before the operator performs the function tests.



WARNING

Failure to locate and repair damage, and discover loose or missing parts may result in an unsafe operating condition.

2. Function Tests

- Designed to discover any malfunctions before the telehandler is put into service.

IMPORTANT

The operator must understand and follow the step-by-step instructions to test all telehandler functions.

The operator should make a copy of the Operator's Checklist (see Table 2.6) and fill out the visual and daily maintenance inspections and the function tests sections while performing the items outlined in Section 2.7 and Section 2.8.

IMPORTANT

If telehandler is damaged or any unauthorized variation from factory-delivered condition is discovered, telehandler must be tagged and removed from service.

Repairs to the telehandler may only be made by a qualified service technician. After repairs are completed, the operator must perform visual and daily maintenance inspections & function tests again.

Scheduled maintenance inspections shall only be performed by a qualified service technician (see Table 2.5).

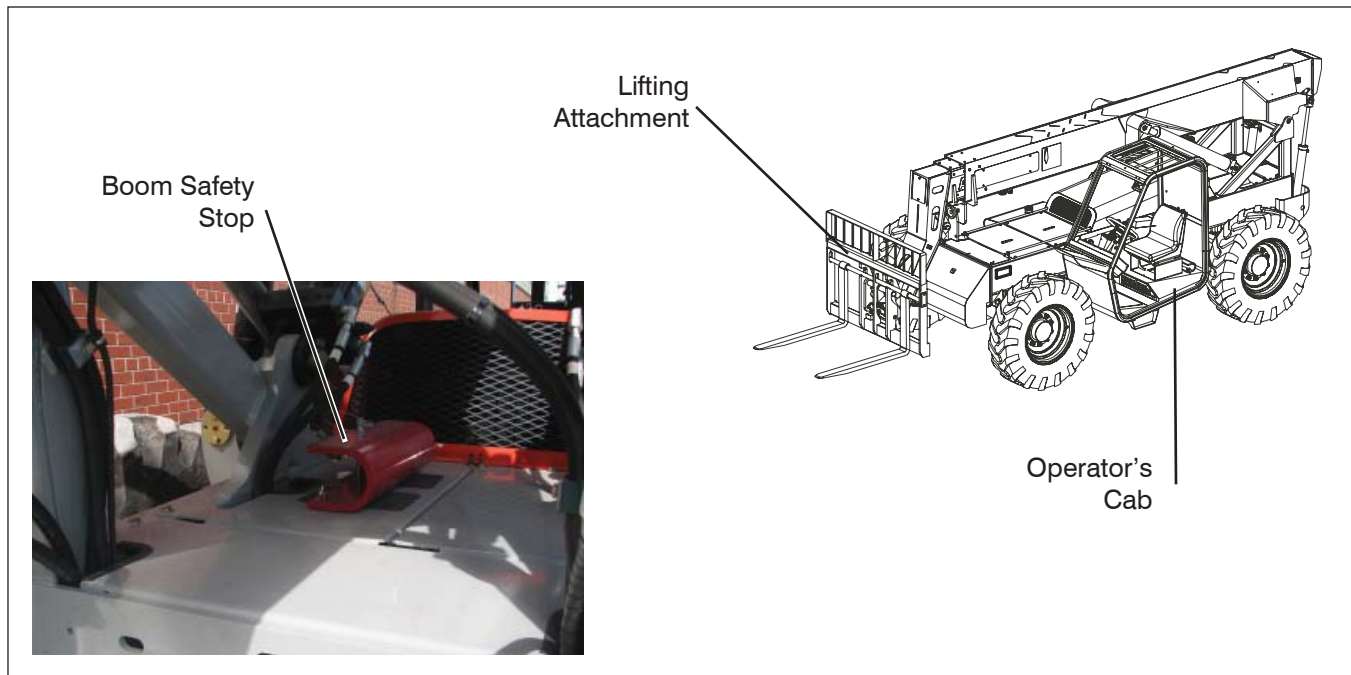

2.7 Visual & Daily Maintenance Inspections

Before performing the visual and daily maintenance inspections, ensure that the telehandler is parked on a firm level surface.

Begin the visual and daily maintenance inspections by checking each item in sequence for the conditions listed in this section.

WARNING

To avoid injury, do not operate a telehandler until all malfunctions have been corrected.

WARNING

To avoid possible injury, ensure telehandler power is off during your visual and daily maintenance inspections.

NOTE

While performing visual and daily inspections in different areas, be aware to also inspect all switches, electrical and hydraulic components.

2.7-1 Labels

Refer to the labels section in this manual and determine that all labels are in place and are legible.

2.7-2 Electrical

Maintaining the electrical components is essential to good performance and service life of the telehandler.

- Ensure proper operation of all gauges
- Check charging system Ammeter/Voltmeter
- Inspect the following areas for chafed, corroded and loose wires:
 - boom wiring harnesses
 - frame wiring harnesses
 - cab wiring harnesses

Ensure electrical devices are properly secured with no signs of visible damage. Ensure there are no loose or missing parts.

2.7-3 Mirrors

Ensure mirrors are properly secured with no signs of visible damage.

2.7-4 Hydraulic

Maintaining the hydraulic components is essential to good performance and service life of the telehandler. Perform a visual inspection and check for leaks around the following areas:

- hydraulic tank, filter(s), fittings, hoses, pump, and frame surface
- all hydraulic cylinders
- all hydraulic manifolds
- underside of the frame
- ground area under the telehandler

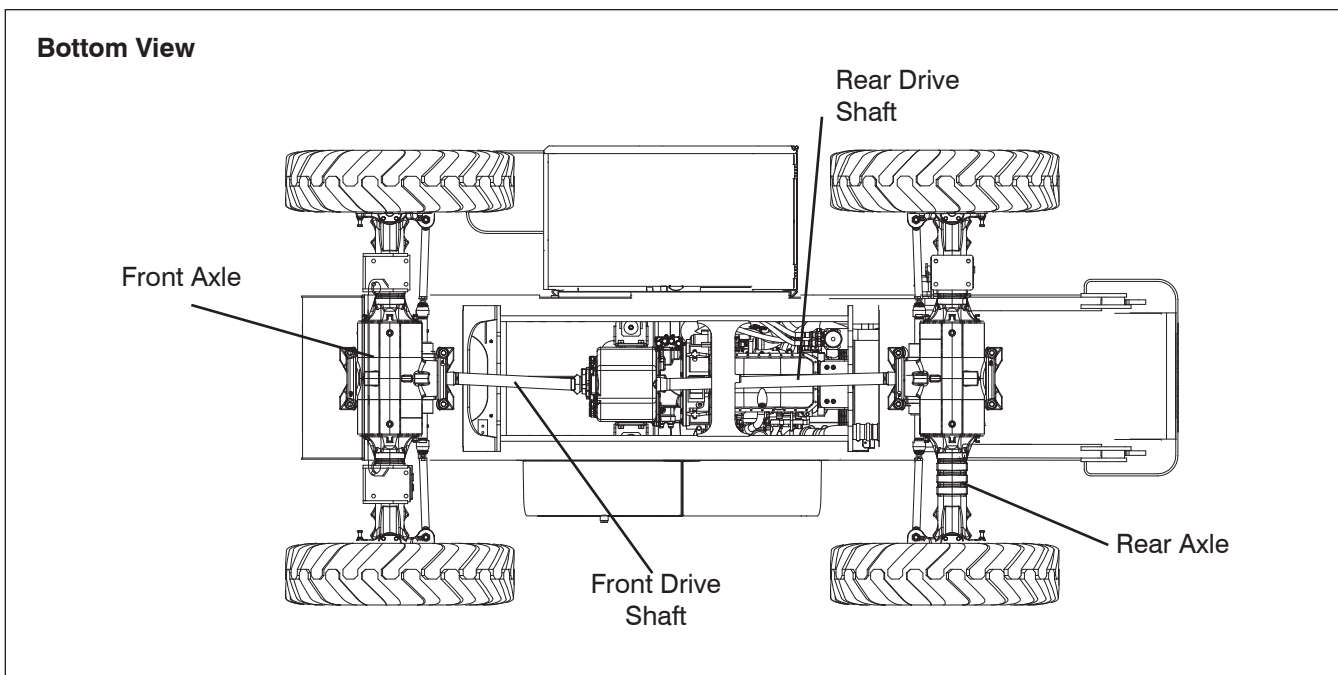

2.7-5 Cylinders

- Ensure all cylinders are properly secured and there is no evidence of leakage.
- Grease weekly and check pins and bushings to ensure there is no evidence of damage.

- Check each lug nut for proper torque to ensure none are loose.

To safeguard maximum stability, achieve optimum telehandler handling and minimize tire wear, it is essential to maintain proper pressure in all air-filled tires.

2.7-6 Frame

• **Wheel/Tire Assembly**

The telehandler is either equipped with air tires or foam-filled tires. Tire and/or wheel failure could result in a telehandler tipover. Component damage may also result if problems are not discovered and repaired in a timely fashion.



WARNING

An over-inflated tire can explode and may cause death or serious injury.

- Check all tire treads and sidewalls for cuts, cracks, punctures and unusual wear.
- Check each wheel for damage and cracked welds.

- Check each tire with an air pressure gauge and add air as needed.

• **Drive Axle**

- Ensure drive axle is properly secured, there are no loose or missing parts, all fittings and hoses are properly tightened and there is no evidence of oil leakage.

• **Steer Cylinder Assembly**

- Ensure steer cylinder assembly is properly secured, there are no loose or missing parts, all fittings and hoses are properly tightened and there is no evidence of hydraulic oil leakage.

• **Steer Linkage**

- Ensure there are no loose or missing parts, steer linkage studs are locked and there is no visible damage.

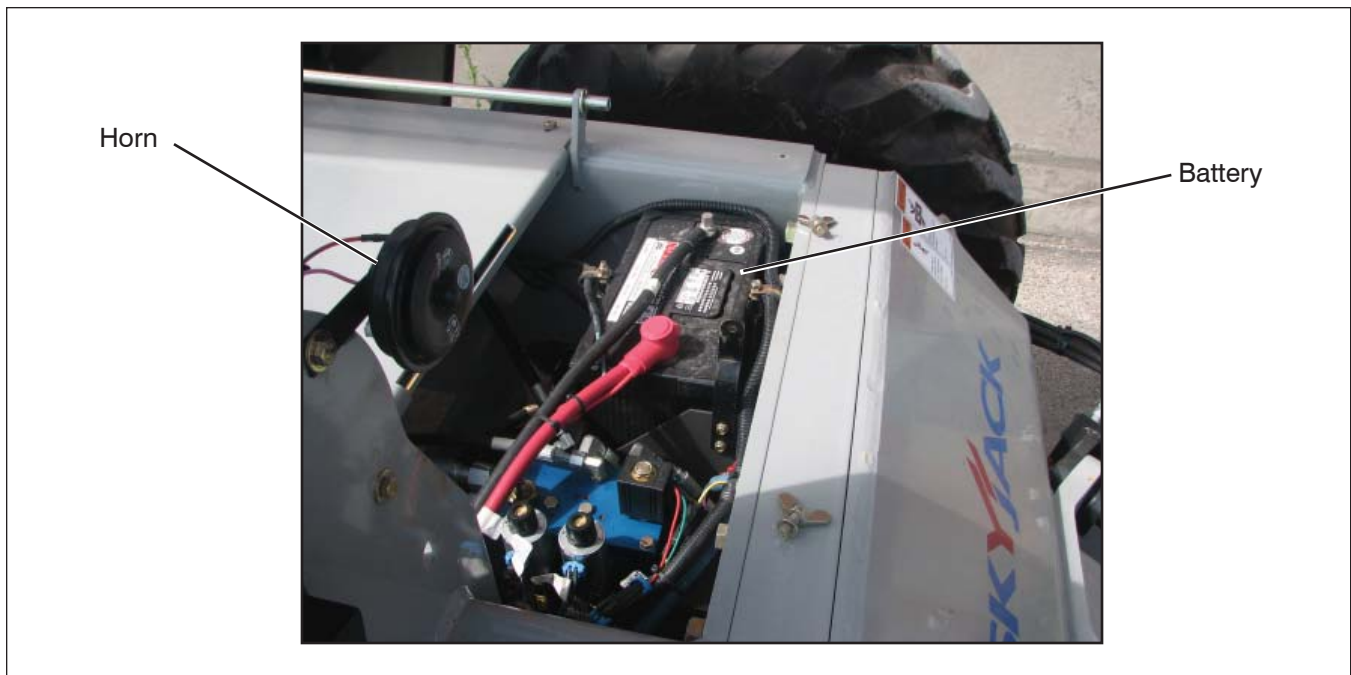

- **Batteries**

Proper battery condition is essential to good engine performance and operational safety. Improper fluid levels or damaged cables and connections can result in engine component damage and hazardous conditions.

 **WARNING**

Explosion hazard. Keep flames and sparks away. Do not smoke near batteries.



 **WARNING**

Battery acid is extremely corrosive - Wear proper eye and facial protection as well as appropriate protective clothing. If contact occurs, immediately flush with cold water and seek medical attention.

1. Check battery case for damage.
2. Clean battery terminals and cable ends thoroughly with a terminal cleaning tool or wire brush.
3. Ensure all battery connections are tight.
4. If applicable, check battery fluid level. If plates are not covered by at least 1/2" (13 mm) of solution, add distilled or demineralized water.

5. Replace battery if damaged or incapable of holding a lasting charge.

 **WARNING**

Use original or manufacturer-approved parts and components for the telehandler.

- **Engine Air Filter**

- Ensure there are no loose or missing parts and there is no visible damage.
- Ensure air cleaner vacuumator valve (if applicable) is free from dirt or dust by squeezing the valve lips.

- **Engine Coolant**

- Check coolant level by removing radiator cap. The coolant level should be within 38 mm (1.5 in.) of the bottom of the cap. Add coolant as needed. Refer to your engine manual for recommended coolant mixture.

- **Muffler and Exhaust**

- Ensure muffler and exhaust systems are properly secured, with no evidence of damage.

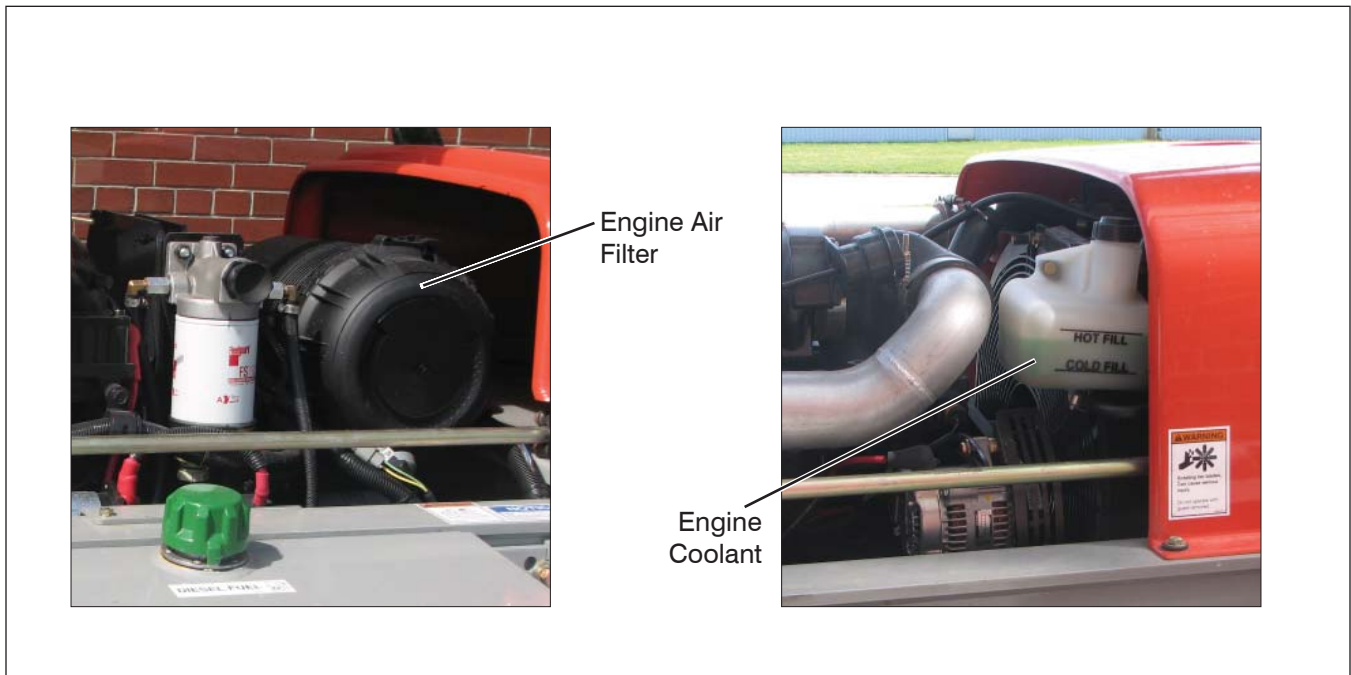

2.7-7 Engine Compartment

- Ensure compartment cover is secure and in proper working order.
- **Engine Oil Level**
 - Maintaining the engine components is essential to good performance and service life of the telehandler.



WARNING

Beware of hot engine components.

- **Check oil level on dipstick**
 - Oil level should be between the “L” low and “H” high marks. Add oil as needed. Refer to Table 2.4 for recommended oil type.
- **Fuel Leaks**

Failure to detect and correct fuel leaks will result in an unsafe condition. An explosion or fuel fire may cause death or serious injury.



DANGER

Engine fuels are combustible. Inspect the telehandler in an open, well-ventilated area away from heaters, sparks and flames. Always have an approved fire extinguisher within easy reach.

Perform a visual inspection around the following areas:

- hoses and fittings
- fuel pump
- fuel filter
- fuel tank
- **Hydraulic Pump**
 - Ensure there are no loose or missing parts and there is no visible damage.
 - Ensure all bolts are properly tightened.
 - Ensure all fittings and hoses are properly tightened and there is no evidence of hydraulic oil leakage.
- **Belts**
 - Ensure belts are in good working condition and have correct tension. Replace if belts are cracked, frayed, or have chunks of material missing. Refer to service manual for proper replacement procedure.
- **Fuel Tank**

IMPORTANT

Before using your telehandler ensure there is enough fuel for expected use.

- Ensure fuel filler cap is secure.
- Ensure tank shows no visible damage and no evidence of fuel leakage.

Engine Compartment - Tank Side

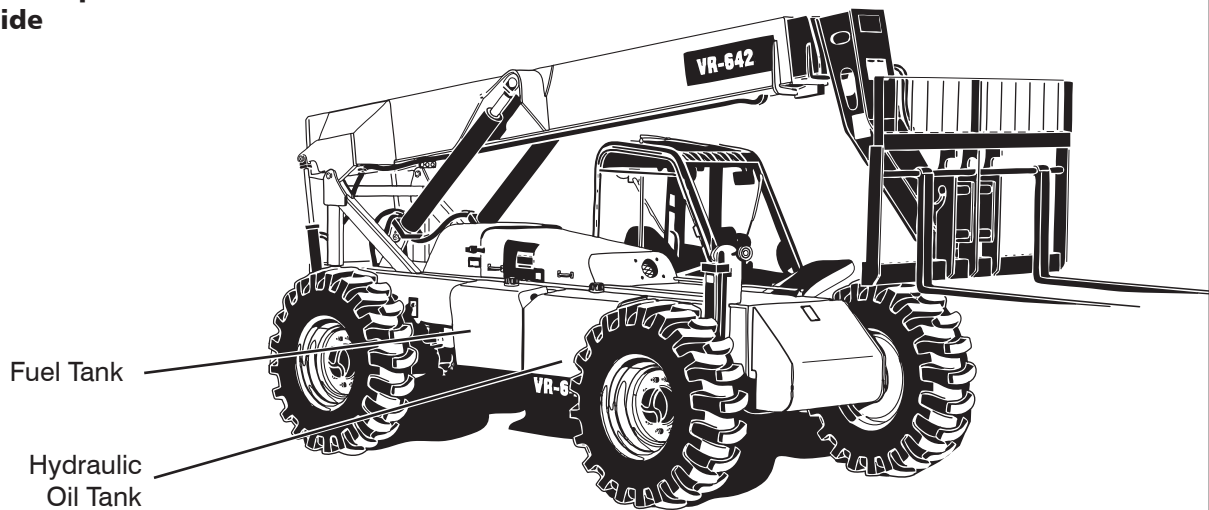

- **Hydraulic Tank**
 - Ensure hydraulic filler cap is secure.
 - Ensure tank shows no visible damage and no evidence of hydraulic leakage.
- **Hydraulic Oil**
 - Be sure that the boom is in the stowed position, and then visually inspect the sight gauge located at the front of the hydraulic oil tank.
 - Add fresh clean hydraulic oil as required. Refer to Table 2.4 for recommended oil type.
- **Hydraulic Suction Filter**
 - Ensure filter element is secure.
 - Ensure there are no signs of leakage or visible damage.

2.7-8 Transmission

- Ensure transmission shifter is working properly and there is no evidence of damage.
- **Check oil level on dipstick**
 - Oil level should be in the “safe” zone. Add oil as needed. Refer to Table 2.4 for recommended oil type.

2.7-9 Boom

- Ensure there are no loose or missing parts and there is no visible damage.
- Ensure all bolts and pins are properly tightened.
- Ensure there are no visible cracks in welds or structure and there are no signs of deformation.
- Ensure all hoses are properly tightened and there is no evidence of hydraulic leakage.
- **Boom Angle Sensor**
 - Ensure boom angle sensor is properly secured with no signs of visible damage.
- **Slide Pads**
 - Ensure all bolts are tight, there is no visible damage to the slide pads and that no parts are missing.
- **Chain**
 - Ensure there are no loose or missing parts and there is no visible damage
- **Boom Angle Indicator**
 - Ensure all bolts are tight, and there is no visible damage

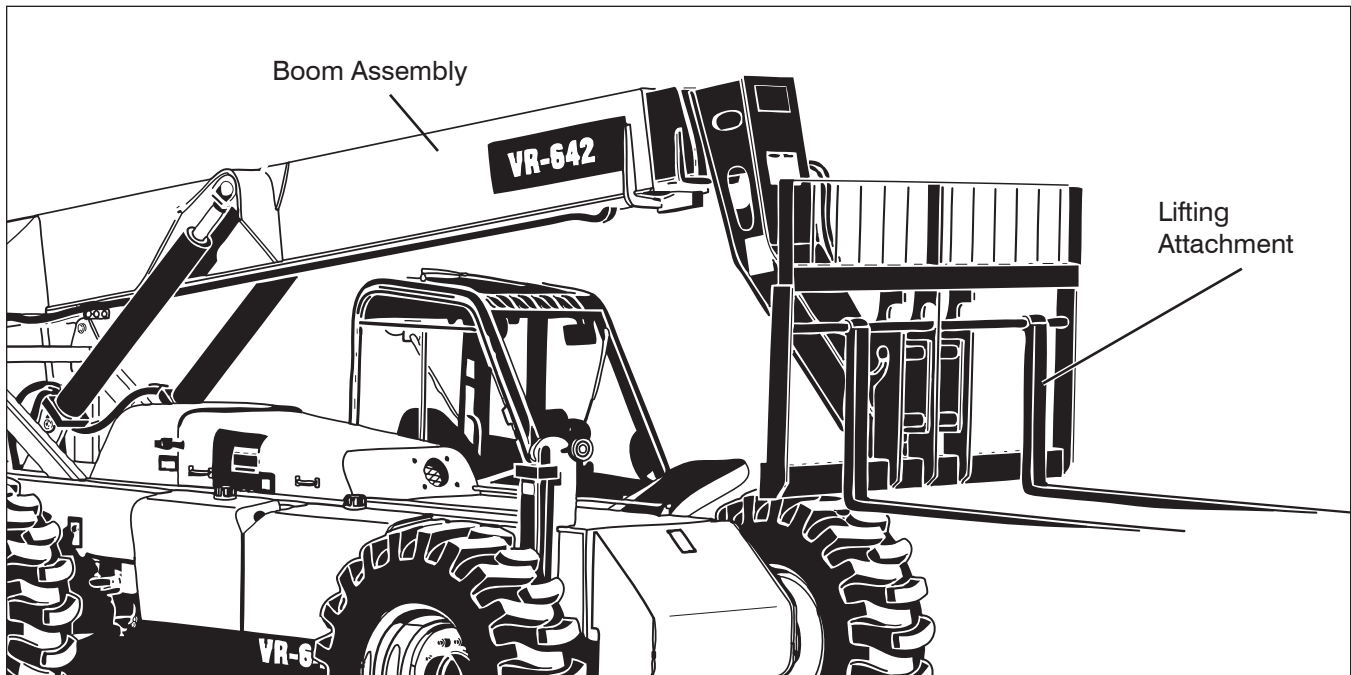

2.7-10 Lifting Attachment

- Ensure there are no loose or missing parts and there is no visible damage.
- Ensure attachment is properly positioned and secured. (refer to Section 2.12 for attachments)

2.7-11 Grease Fittings

Maintaining properly greased components is essential for good performance and service life of the telehandler. If components are improperly greased, it could result in component damage.



WARNING

Ensure that there are no personnel or obstructions in maintenance area.

Greasing intervals are based on telehandler usage of 40 hours. Use of telehandler may vary significantly and greasing frequency must be adjusted to obtain maximum service life.

Grease Fittings on Frame

1. Ensure telehandler is on a firm level surface and is in stowed position.
2. Locate grease fittings (refer to label on engine compartment cover) and pump grease in the following:
 - axle pivot bearings (front and rear)
 - axle lock cylinder (top and bottom)
 - lift cylinder (top and bottom, both sides)
 - frame level cylinders (top and bottom)
 - stabilizer pins (if equipped)
 - slave cylinders (top and bottom)
3. Using a creeper, slide under the frame to locate grease fittings and pump grease in the following:
 - drive shaft U-joint (front and rear)
 - slip joint on drive shaft (front and rear)

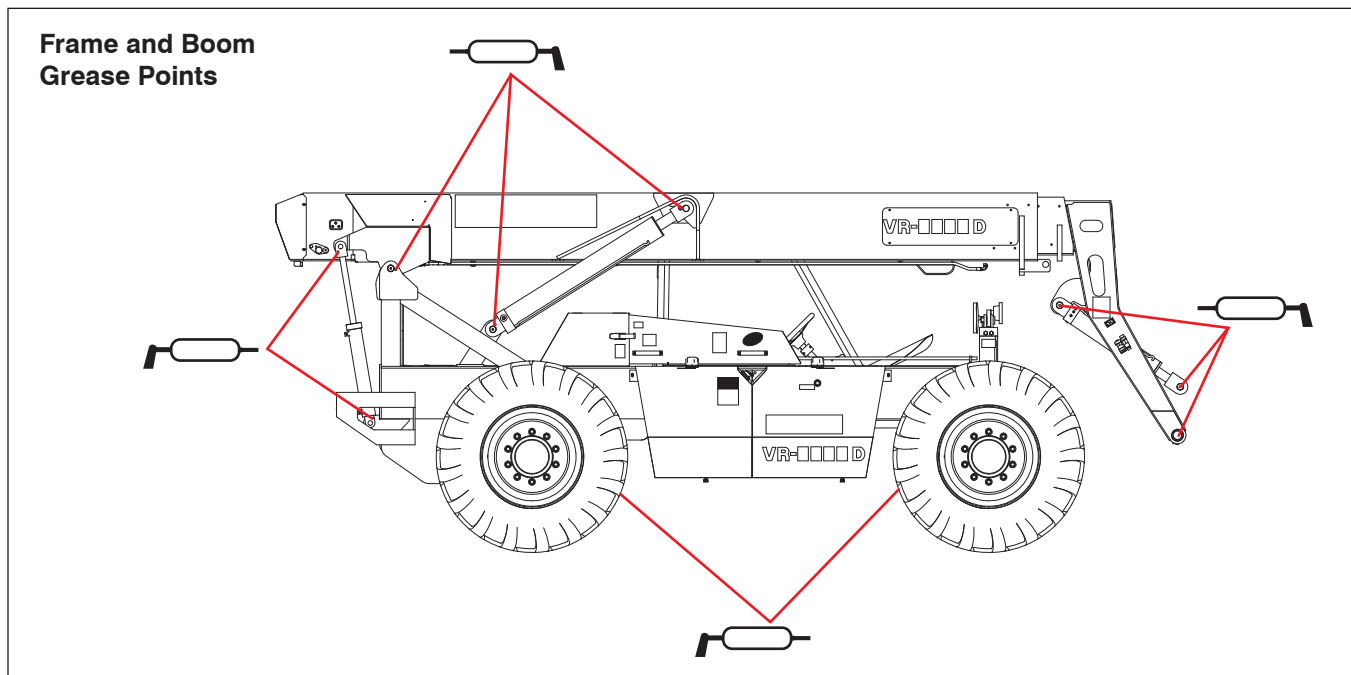

Grease Fittings on Boom Assembly

1. Ensure telehandler is on a firm level surface and is in stowed position.
2. Locate grease fittings (refer to label on engine compartment cover) and pump grease in the following:
 - main boom pivot bearing pins
 - retract chain rollers
 - hose rollers
 - extension chains and rollers
 - slide pads
 - attachment tilt cylinders (top and bottom)
 - attachment pivot bearings

2.7-12 Operator's Cab

- **Rollover and Falling Object Protective Structure (ROPS/FOPS)**
 - Ensure there is no visible damage.



WARNING

Do not modify, drill or alter the operator's cab in any way.

- **Seat**
 - Ensure seat is properly secured with no sign of visible damage.
 - Ensure seat belt is working properly with no sign of visible damage.
- **Pedals**
 - Ensure brake and accelerator pedals are secure, no loose or missing parts, no sign of visible damage and movements are not obstructed.
- **Manual**
 - Check to be sure manual storage box is present and in good condition.
 - Ensure a copy of operating manual, and other important documentation are enclosed in manual storage box.
 - Ensure manual is legible and in good condition.



- Always return manual to the manual storage box after use.

- Ensure capacity charts are in place and are legible.

• **Operator's Cab Controls**

 **WARNING**

Ensure that you maintain three points of contact to mount/dismount the cab.

Use the steps of telehandler to access operator's cab.

- Ensure door and windows (if equipped) are secure and in proper working order.
- Ensure steering wheel is secured with no sign of visible damage.
- Ensure all switches and controls are properly secured with no sign of visible damage.
- Ensure all switches and controls are returned to their neutral positions and movements are not obstructed.

 **DANGER**

Do not operate the telehandler if capacity charts are missing or not legible.



2.8 Function Tests

Function tests are designed to discover any malfunctions before telehandler is put into service. The operator must understand and follow step-by-step instructions to test all telehandler functions.

IMPORTANT

Never use a malfunctioning telehandler. If malfunctions are discovered, telehandler must be tagged and placed out of service. Repairs to telehandler may only be made by a qualified service technician.

After repairs are completed, operator must perform a pre-operation inspection and a series of function tests again before putting telehandler into service.

Prior to performing function tests, be sure to read and understand Section 2.9 - Start Operation.

! WARNING

Ensure that there are no personnel or obstructions in test area and that there is sufficient room to test all telehandler functions.

2.8-1 Operator's Cab Controls

! WARNING

Ensure that you maintain three points of contact to mount/dismount the cab.

- **Test Starter Operation**

1. Enter cab and close door (if equipped).

! WARNING

The seat belt must be worn at all times.

2. Sit in the driver's seat and fasten seat belt.
3. Using a spotter, adjust the mirrors.
4. Ensure parking brake is engaged.



5. Insert key into ignition switch and select "I" on position. Turn the key to start position.
6. Allow engine to idle for 30 seconds.

- **Test Horn**

1. Push "Horn" horn on steering wheel.
Result: Horn should sound.

 **WARNING**

If the warning indicator lights illuminate when engine is running, immediately shut down the telehandler and have it serviced.

- **Test Reverse Alarm**

1. Start engine and release park brake switch.
2. Depress service brake pedal and move the transmission lever to "REV" reverse position.
Result: The reverse alarm should sound.

- **Test Boom and Attachment Functions**

 **WARNING**

Ensure there are no personnel or obstructions in test area and there is sufficient room to test all telehandler functions.

1. Ensure the parking brake indicator light is on.
2. Raise the boom by moving the joystick backward.
Result: Boom should raise and boom angle indicator should be functioning.
3. Extend the boom by moving the joystick to the right.
Result: Boom should extend and boom extension indicators are visible.
4. Tilt attachment forward by pressing and holding the left switch up .
Result: Attachment should tilt forward.

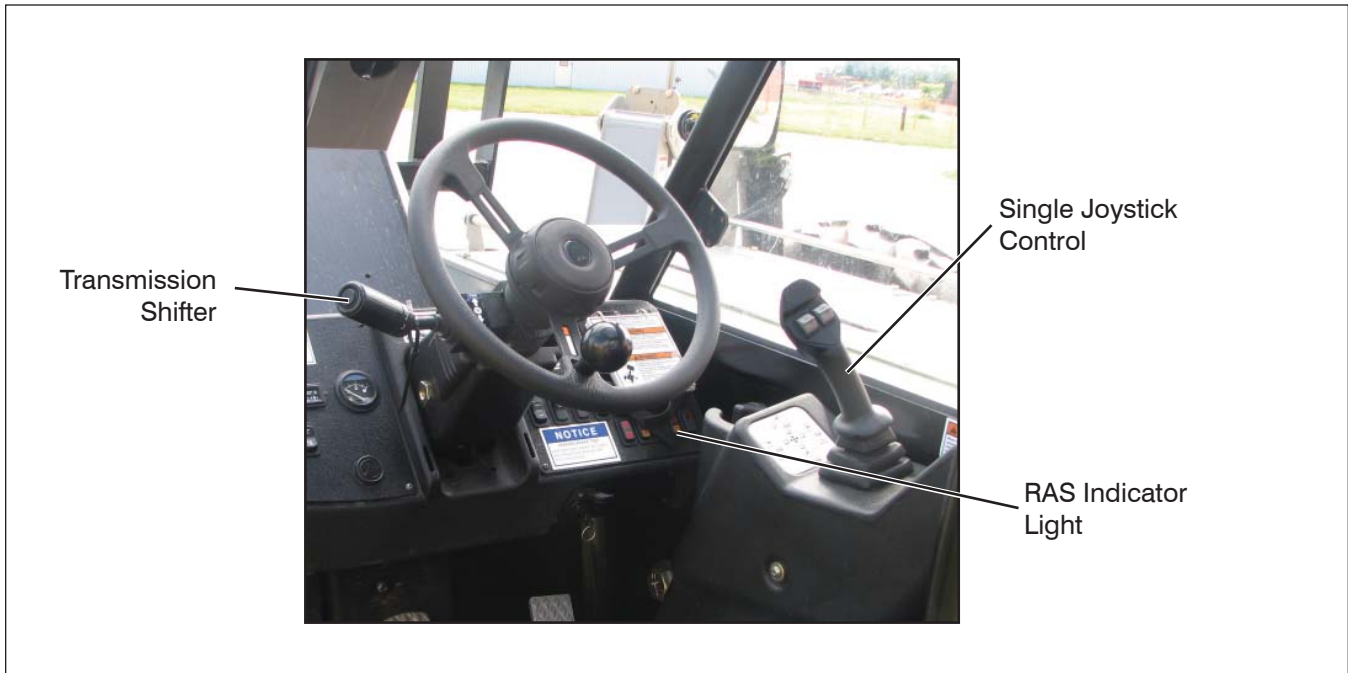

5. Tilt attachment backward by pressing and holding the left switch down.
Result: Attachment should tilt backward.
6. Retract the boom by moving the joystick to the left.
Result: Boom should retract.
7. Lower the boom by moving the joystick forward.
Result: Boom should lower.
8. Lower the boom until attachment is 2 feet above the ground.

NOTE

Ensure to test all attachment functions if telehandler is equipped with optional attachments. (refer to Section 2.12 and 2.13 for attachment operation).

• **Test Frame Leveling and Level Indicator**

1. Ensure parking brake switch is on.
2. Tilt the frame to the right by pressing and holding button at back of joystick and moving the joystick to the right.
Result: Frame should tilt to the right.
3. Tilt frame to the left by pressing and holding button at back of joystick and moving the joystick to the left.
Result: Frame should tilt to the left.
4. Use the frame level indicator to ensure frame is level.



- **Test Accelerator Pedal**

1. Ensure parking brake switch is on.
2. Depress accelerator pedal slowly.
Result: The engine RPM should increase.
3. Release the accelerator pedal.
Result: The engine RPM should decrease.

- **Test Driving & Service Brake Functions**

1. Ensure path of intended motion is clear.
2. Ensure all four wheels are aligned straight ahead.
3. Depress service brake pedal.
4. Release parking brake.
Result: Parking brake indicator light should turn off.
5. Lift transmission lever up from lock position and move to “FWD” forward position then release the service brake pedal slowly.
Result: Telehandler should move forward.

6. Depress service brake pedal slowly.
Result: Telehandler should stop.

7. Move transmission lever to “REV” reverse position and release the service brake pedal slowly.
Result: Telehandler should move backward.

8. Depress service brake pedal slowly.
Result: Telehandler should stop.

9. Return transmission lever to neutral position and engage parking brake.

- **Test Steering**



CAUTION

Before changing steering modes, bring all four wheels into alignment (i.e., in the straight-ahead position).



WARNING

Before driving on public roads and highways check the alignment of the wheels and drive with FRONT steering only.



WARNING

Do not change steer mode while telehandler is traveling.

NOTE

Avoid steering the wheels while telehandler is stationary.

Coordinated (4 wheel)

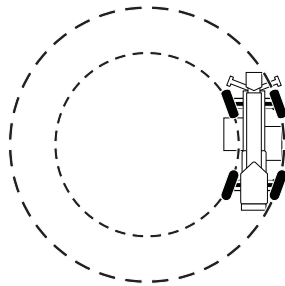



Figure 2-4. Coordinated Steering

1. Ensure path of intended motion is clear.
2. Ensure all four wheels are aligned straight ahead.
3. Release parking brake switch and depress service brake pedal.

4. Press the upper portion of the steering mode selector switch “” for coordinated steering.
5. Turn the steering wheel to the left or right and drive forward.
Result: Telehandler should move in the chosen direction, producing a turning circle, with front wheels pointing in the opposite direction to the rear wheels.
6. Steer telehandler straight ahead until all four wheels are aligned.
7. Depress service brake pedal until the telehandler stops.

Front Steer (2 wheel)

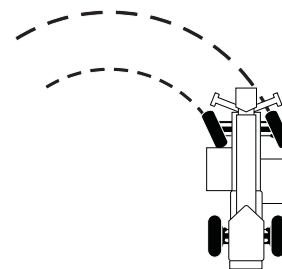



Figure 2-5. Front Steering



8. Select steering mode selector switch to middle “” position for front steering.
9. Turn steering wheel to the left or right and drive forward.
Result: Only front wheels of the telehandler should turn in the chosen direction.
10. Steer telehandler straight ahead until all four wheels are aligned.
11. Depress service brake pedal until telehandler stops.

12. Press the lower portion of the steering mode selector switch to backward “” for crab steering.
13. Turn the steering wheel left or right and drive forward.
Result: Telehandler should move in chosen direction with both front and rear wheels in the same direction.
14. Steer telehandler straight ahead until all four wheels are aligned.
15. Depress service brake pedal until telehandler stops.

Crab Steer

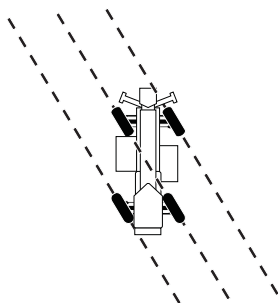

Figure 2-6. Crab Steering

• **Test Parking Brake**



Refer to Section 2.9-3 for instructions on how to drive on a slope.

1. Ensure path of intended motion is clear.



2. Move park brake switch to the “ON” position.
Result: Red indicator light on park brake switch illuminates.
3. Depress service brake pedal then press park brake test switch.
4. Rotate transmission range selector to ‘2’ (2nd gear) position, then lift and move the direction lever to the “FWD” forward position.
5. Depress throttle pedal completely to the floor and slowly remove pressure from service brake pedal.
Result: Telehandler should not move forward.

• **Test Stabilizers (If Equipped)**





- Stabilizers stabilize the telehandler when lifting and placing a load only. They are not outriggers and are not designed to lift the telehandler.

- Always raise the stabilizers completely before driving the telehandler. Failure to have the stabilizers in the upright position may result in damage to the telehandler.

NOTE

To enhance telehandler stability, stabilizers are best used in combination with the automatic Rear Axle Stabilization (RAS) system.

1. Ensure parking brake switch is on.
2. Lower stabilizers by pressing down and holding rocker switch “”.
Result: Stabilizers should lower down.
3. Raise stabilizers by depressing up “” and holding rocker switch until stabilizers are fully raised.
Result: Stabilizers should raise up.

2.9 Start Operation

Carefully read and completely understand the Operating Manual and all warnings and instruction labels (refer to labels section) on the telehandler.



WARNING

DO NOT operate this telehandler without proper authorization and training. Failure to avoid this hazard could result in death or serious injury.

Before operating this telehandler, perform the following steps:

1. Visual and daily maintenance inspections (see Section 2.7)
2. Function tests (see Section 2.8)
3. Jobsite inspection
It is the responsibility of the operator to perform a jobsite inspection and avoid the following hazardous situations:
 - holes or drop-offs
 - ditches or soft fills
 - floor obstructions, bumps or debris
 - overhead obstructions
 - electrical cords, hoses and high voltage conductors
 - hazardous locations
 - inadequate surface support to withstand all load forces imposed by the telehandler
 - wind and weather conditions
 - the presence of unauthorized personnel
 - other possible unsafe conditions



WARNING

An operator should not use any telehandler that:

- does not appear to be working properly.
- has been damaged or appears to have worn or missing parts.
- has alterations or modifications not approved by the manufacturer.
- has safety devices which have been altered or disabled.
- has been tagged or blocked out for non-use or repair.

Failure to avoid these hazards could result in death or serious injury.

2.9-1 Starting the Engine



WARNING

Ensure that you maintain three points of contact to mount/dismount the cab.

1. Enter cab and close door (if equipped).
2. Sit in the driver's seat and fasten seat belt.



WARNING

The seat belt must be worn at all times.

3. Ensure parking brake is on and gear selector in neutral position.
4. To start the engine, turn the ignition switch to on position. Turn the key to start position.
5. Allow engine to idle for 30 seconds until low brake pressure light is off.

2.9-2 Driving the Telehandler

NOTE

- Be aware of blind spots when operating the telehandler.
- Ensure that there are no personnel or obstructions in the path of travel, including blind spots.
- When traveling at high rate of speed, use front wheel steering mode.
- Slow the telehandler prior to turning.
- Always look at the direction of travel.
- Travel in reverse only at slow rate of speed. Drive only as fast as condition allows.
- Keep attachment or load low (18 - 24 inches) to the ground which gives the best visibility and stability.
- Ensure stabilizers (if equipped) are fully raised before driving.

The telehandler is equipped with a power-shift transmission. The transmission has forward and reverse gears with speed ranges available in both directions.

1. Depress service brake pedal then lift and move transmission control lever to the desired direction of travel.
2. Release parking brake.
3. Begin selecting first gear and slowly release service brake pedal.
4. Depress accelerator pedal slowly to increase speed. Twist the transmission hand grip to select higher gear until the desired speed is reached.
5. Select appropriate gear for the task being performed. Select lower gear when transporting load, traveling through deep mud, rough terrain, or slopes. Select higher gears only when traveling long distances on smooth terrain without a load.
6. Always bring the telehandler to a complete stop before changing the direction of travel.

2.9-3 Driving on Slopes

! DANGER

Driving on slopes or inclines can be dangerous and result in forklift tipover or loss of load.

! WARNING

- Avoid excessively steep slopes or unstable surfaces. Do not drive across excessively steep slopes under any circumstances.
 - Avoid turning on slopes, if at all possible.
1. Keep load low and proceed with caution.
 2. Reduce travel speed and downshift to a lower gear before reaching a slope.
 3. Ascend and descend slopes with the “heavy end” or the telehandler pointing up the slope.

NOTE

When the telehandler has **no load**, the rear is considered the “heavy end.” Travel with the **attachment pointed downhill**.

When the telehandler is **carrying a load**, the front is considered the “heavy end.” Travel with the **attachment pointed uphill**.

4. When driving across a slope, keep frame level.

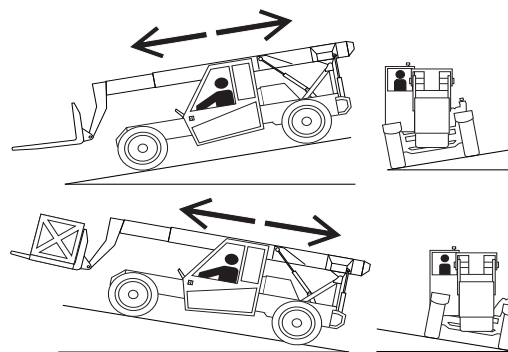

Figure 2-7. Driving on a Slope

2.9-4 Steering the Telehandler

Steering is controlled by means of the steering wheel in conjunction with the steering mode selector rocker switch for the type of steering desired.

Round Steer (4 wheel)

This steer mode is most commonly used on the job site and will give the smallest turn radius available.

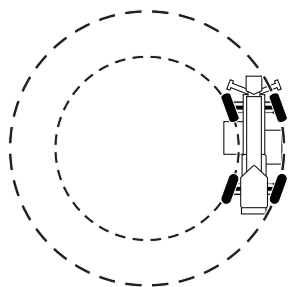

Figure 2-8. Round Steering

Front Steer (2 wheel)

Two-wheel steer is used during road travel in order to reduce the risk of possible overturn due to over-steering.

NOTE

Loss of electrical power will allow front steering only.

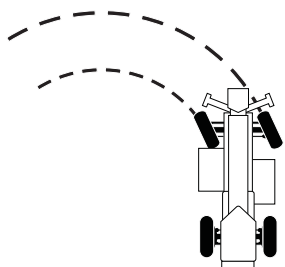

Figure 2-9. Front Steering

Crab Steer

The crab steer is used for maneuvering into tight spots.

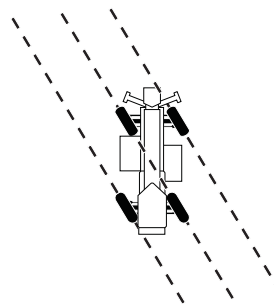

Figure 2-10. Crab Steering

2.9-5 Leveling the Telehandler

1. To level frame to the right, press and hold the push-button (located on bottom of joystick) while moving joystick to the right.
2. To level frame to the left, press and hold the push-button (located on bottom of joystick) while moving joystick to the left.
3. Release the joystick to stop.

2.9-6 Raising or Lowering Boom



WARNING

Ensure that there are no personnel or obstructions and there is sufficient room to perform all telehandler functions.

1. To raise the boom, move the joystick backward. To lower the boom, move the joystick forward.
2. Release the joystick to stop.

2.9-7 Extending or Retracting Boom**WARNING**

Ensure that there are no personnel or obstructions and there is sufficient room to perform all telehandler functions.

1. To extend the boom, move the joystick to the right. To retract the boom, move the joystick to the left.
2. Release the joystick to stop.

2.9-8 Handling Loads**WARNING**

- Before commencing operation, familiarize yourself with the capacity charts specific to telehandler model and attachment.
 - Know the weight of the load and the most extreme height and distance required to pick or place the load.
 - Do not lift load on a gradient steeper than 5%.
 - Never position the load behind front face of the tires.
 - Never drive the telehandler with the boom raised.
 - Ensure not to exceed telehandler lift capacity (refer to capacity charts). Exceeding lift capacity could cause tipover resulting in death or serious injury.
 - When performing lift operation where the operator cannot see load at all times, the operator has to be assisted by a spotter using approved hand signals. (refer to forklift signals label inside cab).
1. Drive as close as possible to load pickup/ placement site.
 2. Place transmission shifter into neutral position and engage parking brake.
 3. Level the frame before lifting the load.
 4. Use stabilizers (if equipped) for maximum stability.
 5. Use attachment to pickup/place the load. Refer to procedure Section 2.13 for specific attachment uses.
 6. Retract boom and keep the attachment/load as low as practical.

2.9-9 Parking and Shutting-down the Telehandler



CAUTION

Operator should observe the following when parking the telehandler:

- Avoid parking on slopes or near excavation, ditches or soft fills. If parking on slopes cannot be avoided, ensure telehandler is positioned at a right angle across the slope.
- Avoid parking on roads or highways. If it cannot be avoided, ensure to display warning flags during the day and flares or flashing lights at night.

1. Position telehandler on a firm and level surface.



WARNING

Always engage parking brake before leaving the cab.

2. Engage parking brake.
3. Move transmission shift lever to neutral position.
4. Ensure transmission gear selector is in first gear position.
5. Retract boom fully and position attachment on ground.
6. Allow engine to idle for 30 seconds.
7. Shut off engine and remove key.



WARNING

Ensure that you maintain three points of contact to mount/dismount the cab.

8. Dismount from telehandler.
9. Chock or block wheels to prevent telehandler from rolling.

2.10 Refueling Procedure (Diesel Fuel Only)

This section provides the operator with procedure on how to refuel telehandler.

IMPORTANT

Before using your telehandler ensure there is enough fuel for expected use.

- Use extreme caution while refueling telehandler.
- Ensure that engine and all systems are turned off before refueling.
- Refuel the telehandler only in a well ventilated area away from open flame and other sources of ignition, authorized by your employer and supervisor.
- To minimize possible static electricity fires, ensure filler nozzle touches rim of filler opening to aid the dissipation of static electricity.
- Never try to start telehandler if you smell diesel.



WARNING

Do not smoke in an area where telehandlers are stored or refueled.

1. Ensure engine and all systems are turned off.
2. Open fuel cap.
3. Carefully pour diesel fuel into the tank, ensuring no spillage occurs.
4. Close and secure fuel cap.
5. Ensure there are no leaks in fuel system.
6. Wipe up any spilled fuel.
7. Dispose of rags in an approved container.

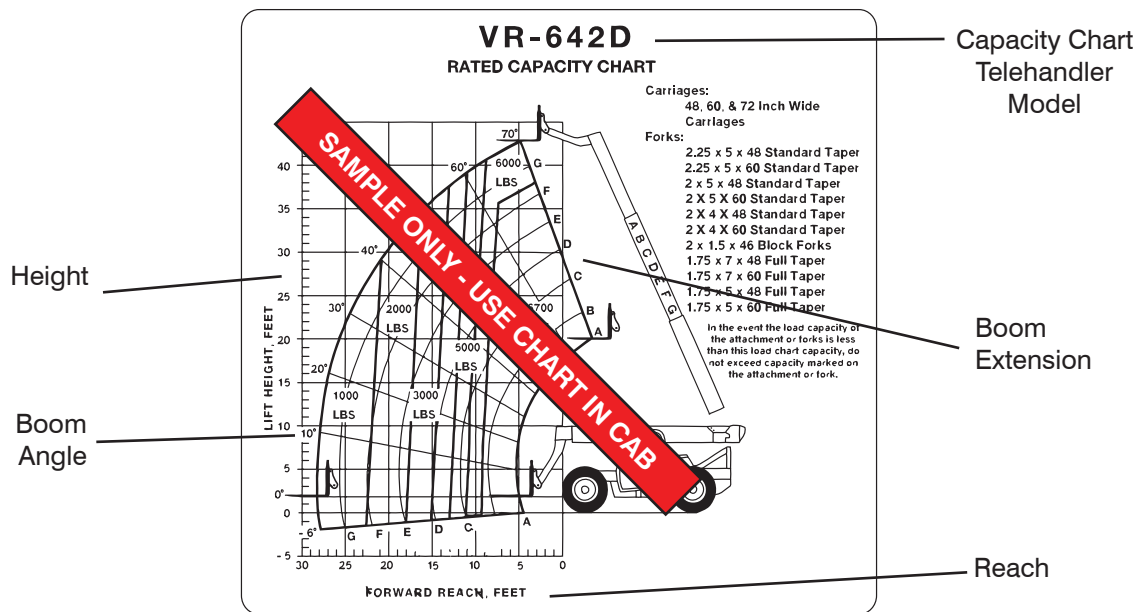

Fig 2-11 Sample Capacity Chart

2.11 Use of the Capacity Charts

The capacity charts are located in the operator’s cab. They are used to determine maximum load capacity for telehandler equipped with different attachment combinations.

To properly use a particular capacity chart, the operator must first determine the following:

1. Ensure the capacity chart is for the specific telehandler model and the attachment.
2. Determine the weight of the load to be lifted.
3. Determine the height where the load is to be picked or placed.
4. Determine the reach where the load is to be picked or placed
5. The maximum capacity is determined by the intersection lines between height and reach on the capacity chart. If the intersection of the lines occurs at a division between capacity zones, the smaller of the two capacity values must be used.

NOTE

The weight of the load must be equal to or less than the number in the capacity zone.



WARNING

When handling load, ensure that boom extension indicator and boom angle indicator remain within previously determined/calculated capacity zone.

2.11-1 Examples on Reading the Capacity Chart

The Operator must verify that the capacity chart corresponds with both telehandler and attachment model number.

The following scenarios show various conditions the operator may encounter:

	Load Weight	Forward Reach	Lift Height	Boom Angle	Boom Extension	Capacity	OK to Lift
1	4000 lbs	6 ft	25 ft	54°	C	6700 lbs	YES
2	6700 lbs	15 ft	20 ft	34°	E	3000 lbs	NO
3	3600 lbs	21 ft	7 ft	9°	E	2000 lbs	NO
4	5500 lbs	5 ft	38 ft	67°	G	6000 lbs	YES
5	800 lbs	26 ft	17 ft	22°	G	1000 lbs	YES
6	4500 lbs	12 ft	10 ft	19°	C	4000 lbs	NO

SAMPLE ONLY - USE CHART IN CAB

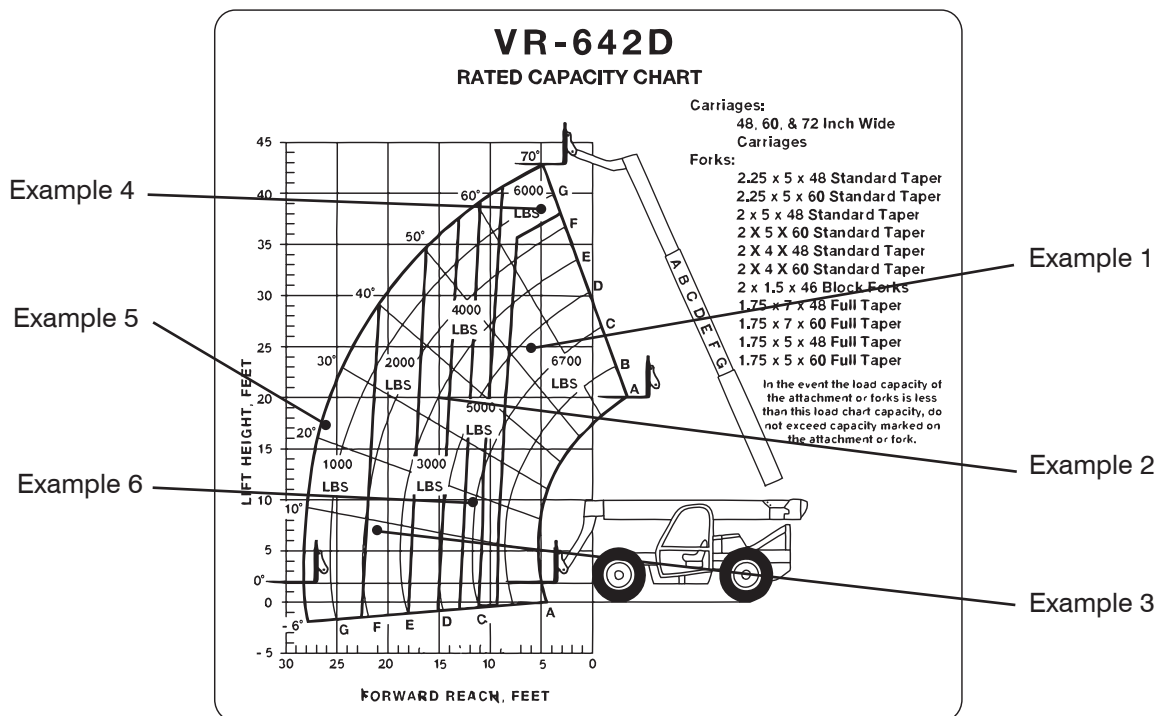

Fig 2-12 Capacity Chart Examples

NOTE

This is a sample capacity chart only! DO NOT use this capacity chart. Use chart inside cab.

NOTE

If the intersection occurs on a bold line separating the capacity regions, the smaller of the two capacity values must be used.

2.12 Attachments Installation and Operation

Several attachments aside from the frequently used attachment/fork combination are available for use with the telehandler. Installation and operation of other approved attachments are covered in this section.

2.12-1 Installing Attachments Using the Quick Attach Feature

1. Fasten the tethered pin assemblies to the apron using the pins, washers, and cotter pins (See diagram below)
2. Ensure the apron is in the tilted forward position with the quick attach pins hanging from the tether.
3. Position the attachment on level ground.
4. Locate the boom so that the apron upper bar can be raised and tilted backwards to engage the attachment and lift it clear of the ground.
5. Engage the attachment as described in step 4, aligning the holes in the attachment for the installation of the quick attach pins at a working height.
6. install the quick attach pins and secure them with linch pins to the outside of the attachment.

2.12-2 Removing Attachments Using the Quick Attach Feature

1. Position the boom so the attachment is just above level ground.
2. Shut down engine.
3. Move the quick attach pins and linchpins from the apron and attachment and leave them in a hanging position.
4. Start engine.
5. Lower boom and tilt the apron forward (while retracting the boom) to clear the attachment.



WARNING

Visually check the attachment is correctly coupled and secured to the boom before operating the telehandler.

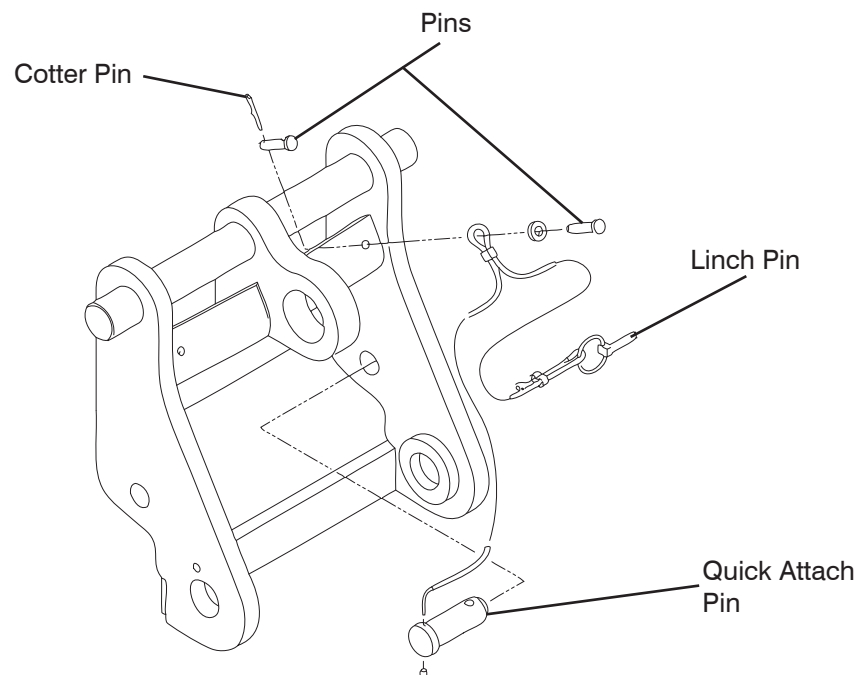

Figure 2-13 Quick Attach Apron

2.12-3 Handling Loads at Ground Level



WARNING

- Handle only loads within the rated capacity as shown on the capacity charts mounted on the telehandler.
- Ensure the capacity chart used corresponds to the attachment fitted to the telehandler.
- Use only manufacturer's approved attachments. The use of non-approved attachments may cause telehandler instability and tipover, which may result in severe injury or death to operators or bystanders.
- Ensure that the load center for the load is at or within 24 inches of forks.
- Deploy stabilizers (if equipped) to stabilize the telehandler during operations involving heavy loads.
- Use a spotter when possible to assist in handling the load.

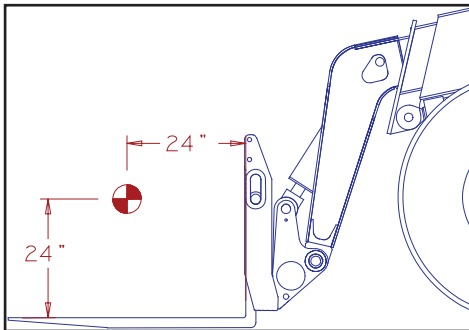

Figure 2-14 Load Center

Picking up a Load

1. Move the transmission lever to neutral and apply parking brake.
2. Check that the telehandler is level using the level indicator. Adjust frame level if necessary.
3. Ensure the forks are as far apart as possible for the width of the load. This increases the stability of the load and the lift.
4. Approach load slowly with forks straight ahead and perpendicular to the load.

5. Deploy stabilizers (if equipped) for maximum stability and insert forks under the load; making sure not to extend forks past the load so that any loads or equipment behind the load being lifted are not damaged, then raise it for 5 to 10 inches.
6. Tilt forks backwards and fully retract boom
7. Raise stabilizers, then check telehandler stability before transporting the load.

NOTE

If the forks are longer than the load, move the forks under the load so that the tips of the forks do not extend beyond the load. Lift the load from the surface. Move backward a few millimeters (inches), then lower the load onto the surface and move forward to engage the load against the carriage. Tilt the forks backward just far enough to lift the load from the surface. When the boom is raised from the surface level, the tips of the forks move in an arc.

Transporting a Load



WARNING

When transporting a load, always travel according to jobsite and weather conditions.

1. Travel with caution to placement site with load kept as low to the ground as possible.
2. Keep load against carriage and forks tilted backward. This position keeps the load on the forks and provides better forward and side stability.
3. Apply brakes smoothly to bring telehandler to a complete stop before applying parking brakes.

Placing a Load

1. Move the transmission lever to neutral and apply parking brake.
2. Deploy stabilizers (if equipped) and check that the telehandler is level using the level indicator. Adjust frame level if necessary.

3. Extend boom to the desired reach and tilt forks forward in a horizontal position.
 4. Place load in a horizontal position then lower boom until load is completely off the forks. Do not apply downward force with the forks.
 5. Free the forks gradually by lowering and retracting the boom alternately.
 6. When forks are clear of the load, fully retract the boom.
 7. Raise stabilizers (if equipped) and return to transport position.
3. Ensure the forks are as far apart as possible for the width of the load. This increases the stability of the load and the lift.
 4. Approach load slowly, raise and extend the boom until the forks are perpendicular to the load.
 5. Deploy stabilizers (if equipped) for maximum stability of telehandler.
 6. Extend and lower the boom to insert the forks under load ; making sure not to extend forks past the load so that any loads or equipment behind the load being lifted are not damaged, then raise it 5 to 10 inches.
 7. Tilt forks backwards. Fully retract the boom and raise stabilizers (if equipped), then check telehandler stability before transporting the load.

2.12-4 Handling Loads at Variable Heights



- Handle only loads within the rated capacity as shown on the capacity charts mounted on the telehandler.
- Ensure the capacity chart used corresponds to the attachment fitted to the telehandler.
- Use only manufacturer's approved attachments. The use of non-approved attachments may cause telehandler instability and tipover, which may result in severe injury or death to operators or bystanders.
- Ensure that the load center for the load is at or within 24 inches of forks.
- Deploy stabilizers (if equipped) to stabilize the telehandler during operations involving heavy loads.
- Use a spotter when possible to assist in handling the load (refer to forklift signals label located inside operator's cab).

Placing a Load

1. Move transmission lever to neutral and apply parking brake.
2. Deploy stabilizers (if equipped) and check that the telehandler is level using the level indicator. Adjust frame level if necessary.
3. Raise and extend boom until the load is perpendicular over placement point.
4. Place the load in a horizontal position and lower boom until the load is completely off the forks. Do not apply downward force with the forks.
5. Free the forks gradually by lowering and retracting the boom alternately.
6. When forks are clear of the load, fully retract the boom and raise stabilizers (if equipped), then return to transport position.

Picking up a Load

1. Move transmission lever to neutral and apply parking brake.
2. Check that telehandler is level using the level indicator. Adjust frame level if necessary.

2.12-5 Adjusting Forks

1. Adjust the location of both forks manually to suit a pallet pocket spacing as follows:
2. Raise the boom until fork eye is approximately shoulder high.
3. Tilt the attachment forward until the fork pivots on the bar, and no longer resting on the carriage's bottom rail (see Figure 2-15). This prevents binding on the bar, thus aiding its repositioning.

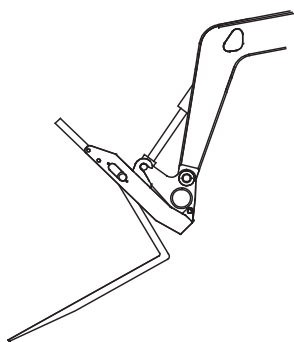

Figure 2-15 Fork Pivoting on the Bar

4. Grasping the fork near its eye, push the fork along the bar until it is in the correct position.

**CAUTION**

Be careful not to pinch fingers between the fork and any portion of the attachment.

2.12-6 Changing Forks

The carriage /fork combination is the most frequently used combination. Different loads may require changing forks with different ratings.

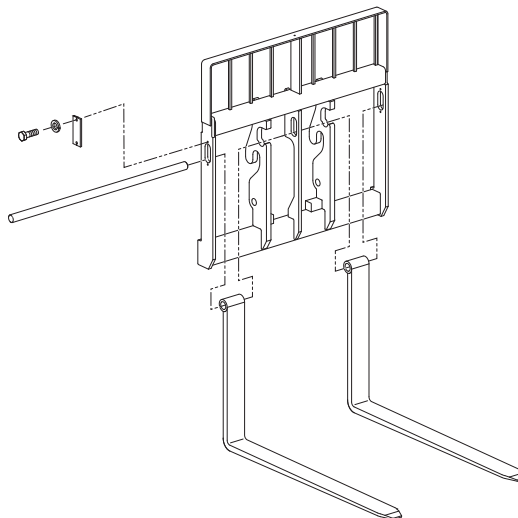

Figure 2-16 Changing Forks

1. Lower the boom with fork contacting the ground until approximately half of the fork float is used up.
2. Remove attachment side plate and inner fork bar collars from fork bar.
3. Draw the bar out of the fork eye and carriage side plate, being careful that the fork doesn't fall over, causing possible injury (see Figure 2-16).
4. Reverse steps 1 through 3 to install the replacement fork.

2.13 Optional Attachments

The SKYJACK VR series telehandler is designed to accept a variety of optional “Quick Attach” attachments aside from regular fork carriage attachment.

2.13-1 Swing Carriage

Swing carriage allows forks to swing left or right, reducing the needed turn angle of telehandler when placing loads. This is used for maneuvering loads in tight locations.

Installation Procedure:

1. Remove fork attachment or other attachment from boom and connect swing carriage attachment (refer to Sections 2.12-1 and 2.12-2).
2. Connect auxiliary hydraulic hoses to swing carriage attachment cylinders.

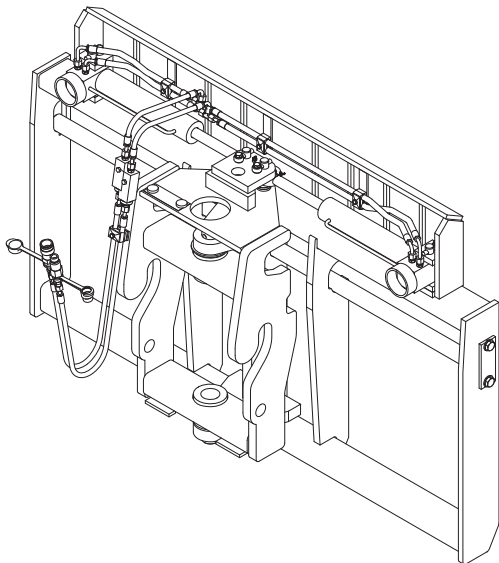

Figure 2-17 Swing Carriage

Operation:

1. Using optional attachment controller, ensure the swing carriage attachment is positioned perpendicular to the load.
2. Handle load the same as regular fork attachment (refer to Sections 2.12-3 and 2.12-4).

2.13-2 Bucket Loader

A bucket loader has a high back and straight sides for cutting into piles of low density materials. This attachment is used for light material handling such as snow removal or transporting of grains and other loose materials. Material buckets are not meant for excavation as high twisting loads can damage the boom.

Installation Procedure:

1. Remove fork attachment or other attachment from boom and connect material bucket (refer to Sections 2.12-1 and 2.12-2).

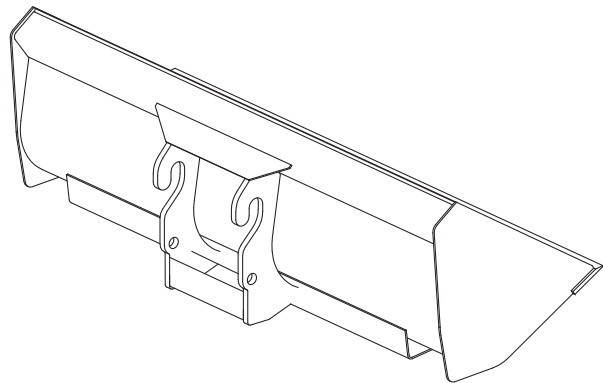

Figure 2-18 Bucket Loader

Operation:

1. Raise or lower boom to appropriate height for loading material from stockpile.
2. Position telehandler so that it is perpendicular to the stockpile. Drive slowly and smoothly into pile to load bucket.
3. Tilt bucket backwards enough to retain the load and back away from pile.
4. Drive to the unloading point and keep bucket approximately 4 feet above the ground.
5. Tilt bucket forward to dump load.

2.13-3 Scrap Grapple Bucket

A scrap grapple bucket is designed to handle and contain bulk materials as well as pipes and round bale materials. The cut-out sides allow the handling of long materials.

Installation Procedure:

1. Remove fork attachment or other attachment from boom and connect scrap grapple bucket attachment (refer to Sections 2.12-1 and 2.12-2).

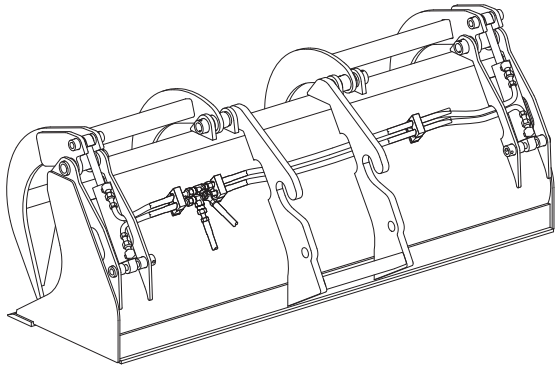

Figure 2-19 Scrap Grapple Bucket

Operation:

1. Raise or lower boom to appropriate height for loading material from stockpile.
2. Position telehandler so that it is perpendicular to the stockpile.
3. Open grapple hooks using optional attachment controls and drive slowly and smoothly into pile to load bucket.
4. Tilt bucket backward enough to retain the load and close grapple hooks then back away from pile.
5. Drive to the unloading point and keep bucket approximately 4 feet above the ground.
6. Open hooks and tilt bucket forward to dump load.

2.13-4 Truss Boom

A truss boom is an attachment with a hook or jib eye load connection. This connection is used for extending the forward reach and lift height of the telehandler at the expense of load capacity.



Mounting truss boom changes center of gravity of telehandler. Consult capacity charts specific to attachment before handling loads.

Installation Procedure:

1. Remove fork attachment or other attachment from boom and connect truss boom attachment (refer to Sections 2.12-1 and 2.12-2).

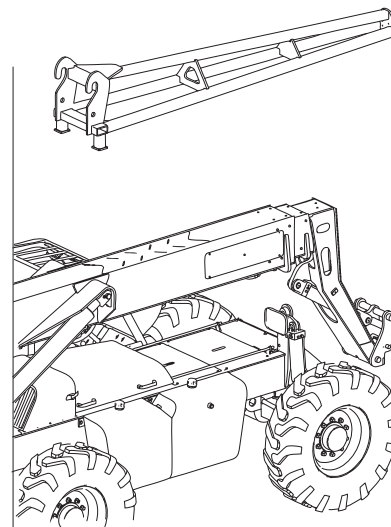

Figure 2-20 Truss Boom

Operation:

1. Using boom controller, adjust truss boom over the center of the load.
2. Attach load to the pintle hook using sufficient chains/cables.
3. While helpers guide the load, position load at placement point.

2.13-5 Side Tilt Carriage

The side tilt carriage allows carriage to tilt to either side.

Installation Procedure:

1. Remove fork attachment or other attachment from boom and connect side tilt carriage attachment (refer to Sections 2.12-1 and 2.12-2).



WARNING

Only qualified service personnel should install hydraulic winch.

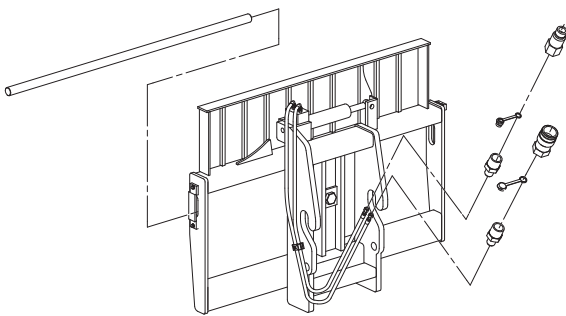

Figure 2-21 Side Tilt Carriage

Operation:

1. Using optional attachment controller, ensure the side tilt carriage attachment is positioned perpendicular to the load.
2. Handle load the same as regular fork carriage attachment (refer to Sections 2.12-3 and 2.12-4)

2.13-6 Pintle Hook

The pintle hook is mounted and connected to a tapped plate located at the rear of the VR-642D or VR-843D as shown in the figure below.

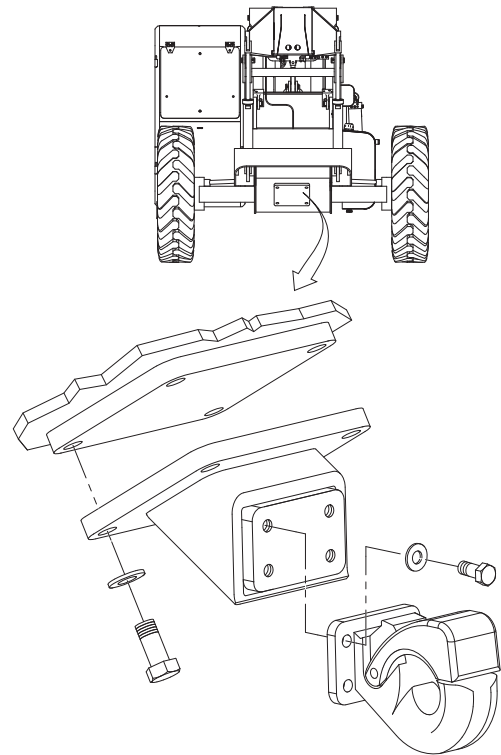

Figure 2-22 Pintle Hook

2.14 Loading and Transporting

Know all national, state/provincial and local rules which apply to transporting of telehandlers.

Only qualified personnel shall operate machinery during loading and transporting.

Be sure vehicle capacity and loading equipment hoists, chains, straps, etc., are sufficient to withstand maximum telehandler weight.

The transport vehicle must be parked on a level surface and must be secured to prevent rolling while telehandler is being loaded or unloaded.

IMPORTANT

All turbo-engines air cleaner and exhaust must be sealed during transport.

2.14-1 Loading and Tie-down

1. Ensure telehandler is level prior to loading.
2. Fully lower and retract boom and raise stabilizers (if equipped).
3. Ensure ramps are correctly positioned.

4. Using a spotter, carefully drive telehandler onto the transporting vehicle.
5. Once telehandler is loaded, apply parking brake and rest the attachment flat on the vehicle platform.
6. Move all controls to neutral position.
7. Turn key switch to "O" off position and remove key before transporting.
8. Chock telehandler wheels (if necessary).
9. Remove all loose items.
10. Anchor down telehandler to transport surface using tie-down points and secure the forks to the platform using sufficient straps. (See diagram below).



WARNING

Inspect telehandler for loose or unsecured items.

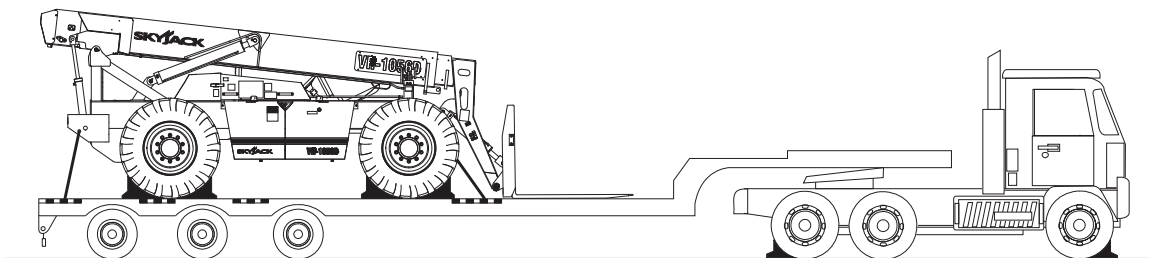
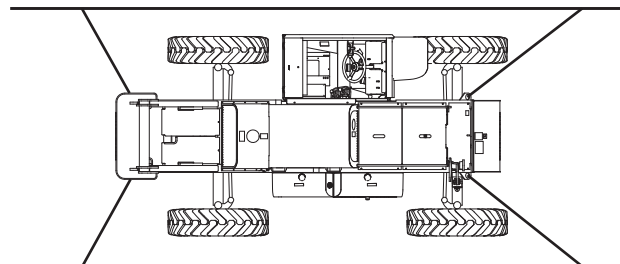

Fig 2-23 Tie-down points

2.14-2 Towing the Telehandler

IMPORTANT

- Use this procedure only to remove telehandler from mud or other places where it cannot move under its own power. When possible, repair telehandler on site.
 - Always chock wheels of the disabled telehandler to prevent accidental movement while preparing for towing. This is especially important if the failure occurs on an incline.
 - Before towing, ensure there are no obstructions around or between telehandler and towing vehicle.
 - The spotter must maintain a safe distance and must always be visible to the operator inside telehandler's cab.
 - Ensure the towing vehicle, chains, tow bar, etc., are suitable for the job. The telehandler weight is stamped on the serial number nameplate.
1. Lower or raise boom and stabilizer (if equipped) enough so that front tie-down points are fully accessible.
 2. Carefully fasten tow chains to tie-down points on either front or rear of telehandler frame.

3. Remove chocks from wheels.
4. Enter cab and fasten seatbelt.
5. Ensure transmission gear selector is in 'neutral' and the transmission lever neutral lock switch is in the 'N' neutral position.
6. Start the engine.
7. Release park brake.
8. Start towing the telehandler while operating the steering and brakes.
9. Move telehandler to a compact level surface.
10. Apply park brake.
11. Turn off engine and remove key from ignition switch.



WARNING

Ensure that you maintain three points of contact to mount/dismount the cab.

12. Dismount from telehandler.
13. Chock or block wheels to prevent telehandler from rolling.



CAUTION

Bad traction can cause telehandler or towing vehicle to slide. Grades can require additional distance to stop the telehandler. Be careful if traction conditions are bad or the machine on an incline.

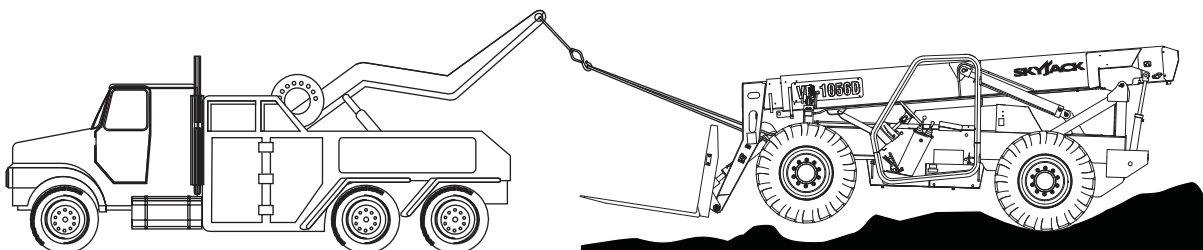

Fig 2-24 Towing the telehandler from front tie-down points

Table 2.1 Standard & Optional Features

MODEL	VR-642D	VR-843D
Diesel Engine	✓	✓
Four-wheel drive	✓	✓
Three-Speed Transmisson	✓	✓
Three-Mode Steering	✓	✓
Open/Enclosed Operator's Cab	✓	✓
Spring-applied Hydraulically Released Parking Brake	✓	✓
Operator horn	✓	✓
Reverse/Backup alarm	✓	✓
Rotating Beacon	x	x
Four-Wheel Fenders	x	x
Engine Block Heater	x	x
Hydraulic Test Port	x	x
Air/Foam Filled Tires	✓	✓
Road/Work/Boom Lights	x	x
Boom Safety Stop	✓	✓
Stabilizers	x	x
Rear Axle Stabilization System (RAS)	N/A	N/A
Frame Leveling System	✓	✓
48" / 60" / 72" QA 10K Fork Carriages	✓	✓
48" / 60" / 72" S/T QA Fork Carriages	x	x
72" Swing Carriage	x	x
1.75 Cu. Yd. Loader Bucket Attachment	x	x
60S QA Fork Positioning Carriage	N/A	N/A
12 ft. Truss Boom	✓	✓
15 ft. Truss Boom	N/A	N/A
Drywall Handler Attachment	x	x
Scrap Grapple Bucket Attachment	x	x
ATF Hydraulic System Oil	x	x

236A-1

Legend

✓ = Standard

x = Optional

N/A = Not Available

Table 2.2 Specifications and Features

MODEL	VR-642D	VR-843D
Engine		
Standard	Cummins B3.3 Tier 3 Diesel Turbocharged	
Cylinders	4	
Horsepower @ 2400 RPM	110 HP	
Capacity	239 cu.in. (3917 cm ³)	
Torque @ 1500 RPM	305 lb.ft. (415 N-m)	293 lb.ft. (397 N-m)
Fuel type	Diesel	
Transmission		
Type	Powershift with soft shift	
Speeds forward	3	
Speeds reverse	3	
Travel Speeds		
Range 1	0-4 mph (1-7 km/h)	
Range 2	5-8 mph (8-13 km/h)	
Range 3	9-20 mph (14-32 km/h)	
Electrical		
Negative ground	12 Volts	
Alternator	62 Amps	
Battery	900 Amps	
Backup Alarm	107 DBM	
Dimensions		
Wheelbase	120 in (304.8 cm)	128 in (325.1 cm)
Overall width	102 in (259 cm)	
Overall height	95 in (241.3 cm)	
Overall length (less forks)	243 in (617 cm)	252 in (640 cm)
Ground clearance	16 in (41 cm)	
Machine weight *	19 677 lbs. (8, 944 kg)	22 158 lbs. (10, 072 kg)
Turn radius (inside)	6.42 ft. (196 cm)	7.17 ft. (218 cm)
Turn radius (outside)	11.94 ft. (364 cm)	12.22 ft. (373 cm)
Boom		
Number of sections	3	
Maximum forward reach	23 ft. 6 in. (716 cm)	
Maximum lift height	504 in (1 208 cm)	517 in (1 313 cm)

257A

Table 2.3 Tire/Wheel Specifications

	VR-642D	VR-843D
Tire Size	13.00 x 24TG G2	
Pressure	75 psi (517.2 kPa)	
Tire Ply Rating	14	
Wheel Nuts Torque	442 ft-lb (600 Nm)	

231B-1

 **WARNING**

Intermixing tires of different types or using tires of types other than those originally supplied with this equipment can adversely affect stability. Therefore, replace tires only with the exact original Skyjack-approved type. Failure to operate with matched approved tires in good condition may result in death or serious injury.

IMPORTANT

For proper function of each axle differential, all four wheels must have same tire size installed at all times. Failure to comply with this requirement will reduce the life of the differentials and reduce overall mobility of telehandler.

Table 2.4 Recommended Fluids/Lubrication

		VR-642D	VR-843D
Engine	Fuel Type	Diesel (#2 ASTMD-975-60T)	
	Fuel Tank Capacity	35 gal (132 L)	
	Recommended Oil Type	SAE 15W40	
	Capacity	7.4 Quart (7.0 L)	
	Coolant Type	50% Water/50% Glycol	
	Capacity	4 gal (15.2 L)	
Transmission	Oil Type	Multipurpose ATF	
	Capacity	13.6 Quart (12.9 L)	
Axles	Differential	Mobilube HD	
	Front Axle Capacity	9.0 Quart (8.51 L)	15.6 Quart (14.76 L)
	Rear Axle Capacity	7.0 Quart (6.62 L)	18 Quart (17.03 L)
	Planetary Wheel Ends	SAE 80W-90EP	
	Capacity	1 Quart (0.95 L)	2 Quart (1.89 L)
Hydraulic Oil	Standard Factory Fill	Mobil DTE 13M or Shell Tellus T-32	
	Approved Alternates*	Multipurpose ATF	
	Tank Capacity	40 gal (151 L)	

235B

 **WARNING**

Intermixing hydraulic oil of different types or using oils of types other than those originally supplied with this equipment can severely damage all hydraulic components. A full hydraulic oil system flush must be performed prior to adding a new type of hydraulic oil. Consult Skyjack service department.

General Maintenance

Before attempting any repair work, turn ignition switch to off position. Preventive maintenance is the easiest and least expensive type of maintenance.

Table 2.5 Maintenance and Inspection Schedule

Frequency	Daily	Weekly	Quarterly or 250 hours	Annually or 1000 hours	Frequency	Daily	Weekly	Quarterly or 250 hours	Annually or 1000 hours	
Visual and Daily Maintenance Inspections					Function Tests					
Labels	A				Operator's Cab Controls					
Electrical	A				Test Horn	A			C*†	
Safety Switches	A				Test Reverse Alarm	A				
Mirrors	A				Test Lights	A				
Hydraulic	A				Test Boom and Attachment Functions	A				
Cylinders	A				Test Frame Levelling and Level Indicator	A				
Frame					Test Frame Level Lock	A				
Wheel/Tire Assembly	A				Test Accelerator Pedal	A				
Drive Axle	A				Test Driving and Service Brake Functions	A				
Steer Cylinder Assembly	A				Test Steering	A				
Steer Linkage	A				Test Parking Brake	A				
Batteries	A				Test stabilizers (if equipped)	A				
Engine Air Filter	A									
Engine Coolant	A									
Muffler and Exhaust	A									
Engine Compartment	A									
Engine Oil Level	A									
Fuel Leaks	A									
Hydraulic Pump	A									
Belts	A									
Fuel Tank	A									
Hydraulic Tank	A									
Hydraulic Oil	A									
Hydraulic Return Filter	A									
Boom										
Slide Pads	A									
Chain	A									
Boom Angle Indicator	A									
Proximity Sensor	A									
Transmission										
Lifting Attachment	A									
Grease Fittings										
Grease Fittings on Frame				B						
Grease Fittings on Boom Assembly				B						
Operator's Cab										
ROPS/FOPS	A									
Seat	A									
Pedals	A									
Manual	A									
Operator's Cab Controls	A									

233B

- A - Perform Visual and Daily Maintenance Inspections & Functions Test. Refer to Section 2.7 and Section 2.8 of this manual.
- B - Perform Visual and Weekly Maintenance Inspections & Functions Test. Refer to Section 2.7 and Section 2.8 of this manual.
- C - Perform Scheduled Maintenance Inspection. Refer to Service & Maintenance manual.
- * - Maintenance must be performed only by trained and competent personnel who are familiar with mechanical procedures.
- † - Refer to Skyjack's website @ www.skyjack.com for latest service bulletins prior to performing quarterly or yearly inspection.

Table 2.6 Operator's Checklist



OPERATOR'S CHECKLIST

Serial Number: _____
 Model: _____
 Hourmeter Reading: _____
 Date: _____
 Time: _____

Operator's Name (Printed): _____

Operator's Signature: _____

Each item shall be inspected using the the appropriate section of the Skyjack operating manual.
 As each item is inspected, check the appropriate box.

- P - PASS
- F - FAIL
- R - REPAIRED
- NA - NOT APPLICABLE

- DAILY
- FREQUENTLY
- QUARTERLY
- ANNUALLY





	N/A	P	F	R
Visual and Daily Maintenance Inspections				
Labels				
Electrical				
Safety Switches				
Mirrors				
Hydraulic				
Cylinders				
Frame				
Wheel/Tire Assembly				
Drive Axle				
Steer Cylinder Assembly				
Steer Linkage				
Batteries				
Engine Air Filter				
Engine Coolant				
Muffler and Exhaust				
Engine Compartment				
Engine Oil Level				
Fuel Leaks				
Hydraulic Pump				
Belts				
Fuel Tank				
Hydraulic Tank				
Hydraulic Oil				
Hydraulic Return Filter				
Boom				
Slide Pads				
Chain				
Boom Angle Indicator				
Proximity Sensor				
Transmission				
Lifting Attachment				
Grease Fittings				
Grease Fittings on Frame				
Grease Fittings on Boom Assembly				
Operator's Cab				
ROPS/FOPS				
Seat				
Pedals				
Manual				
Operator's Cab Controls				

	N/A	P	F	R
Function Tests				
Operator's Cab Controls				
Test Horn				
Test Reverse Alarm				
Test Lights				
Test Boom and Attachment Functions				
Test Frame Levelling and Level Indicator				
Test Frame Level Lock				
Test Accelerator Pedal				
Test Driving and Service Brake Functions				
Test Steering				
Test Parking Brake				
Test stabilizers (If Equipped)				

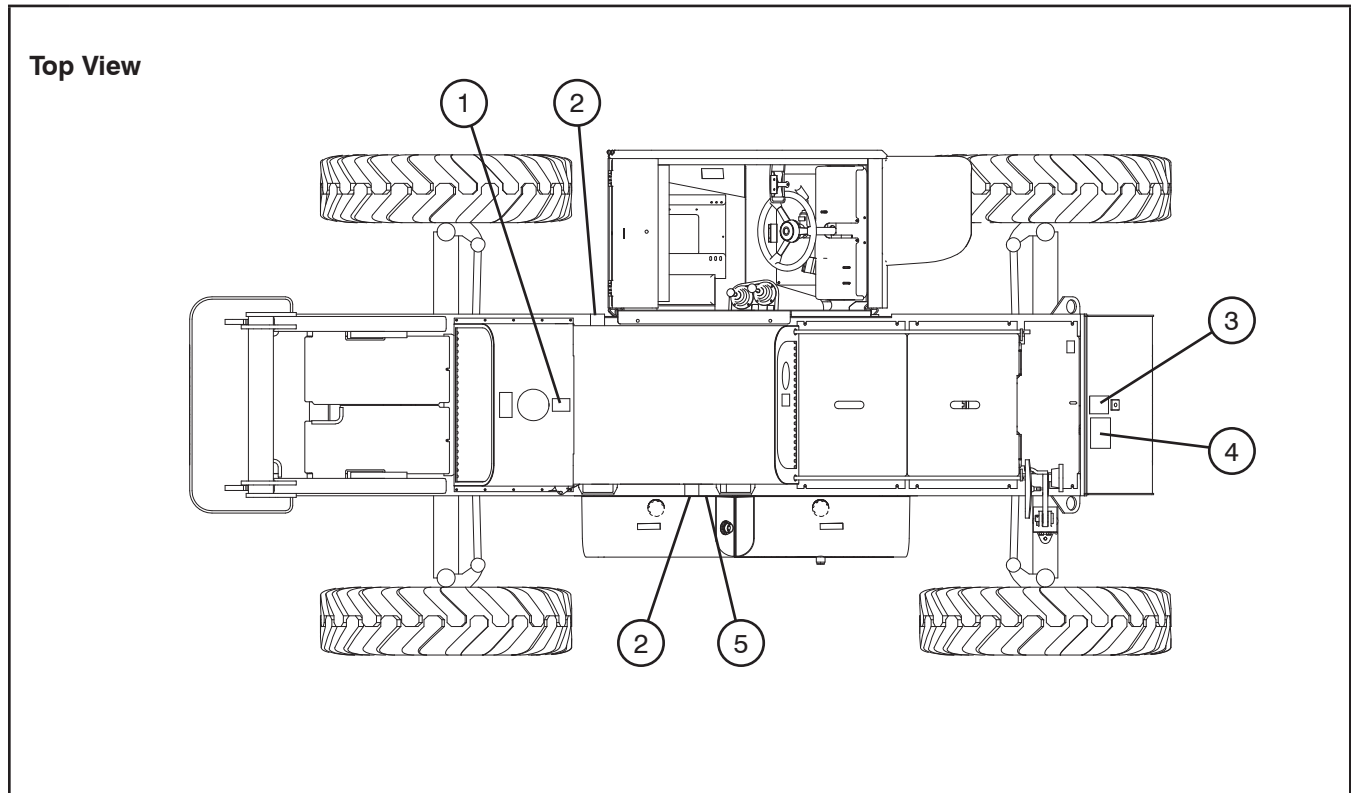
234A

Note:
 Make a copy of this page or visit the Skyjack web site:
www.skyjack.com for a printable copy.



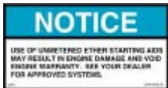

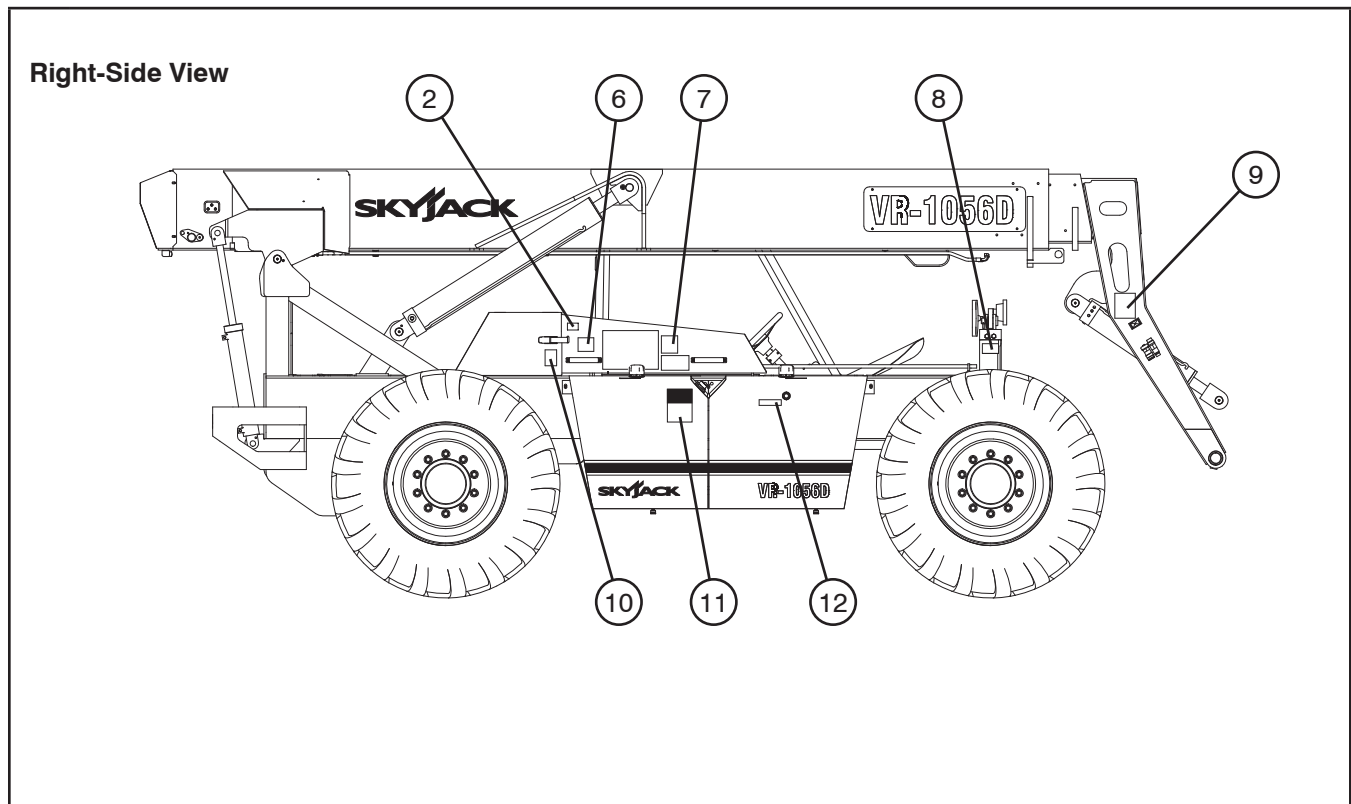
No.	Label Pictorial	Description
1		<p>Pressure Hazard</p> <p>Pressure hazard warning.</p>
2		<p>Moving Machine</p> <p>Moving machine warning.</p>
3		<p>Crush Area</p> <p>Crush area warning</p>
4		<p>Falling Load</p> <p>Falling load warning</p>
5		<p>Unmetered Ether</p> <p>Unmetered ether notice</p>



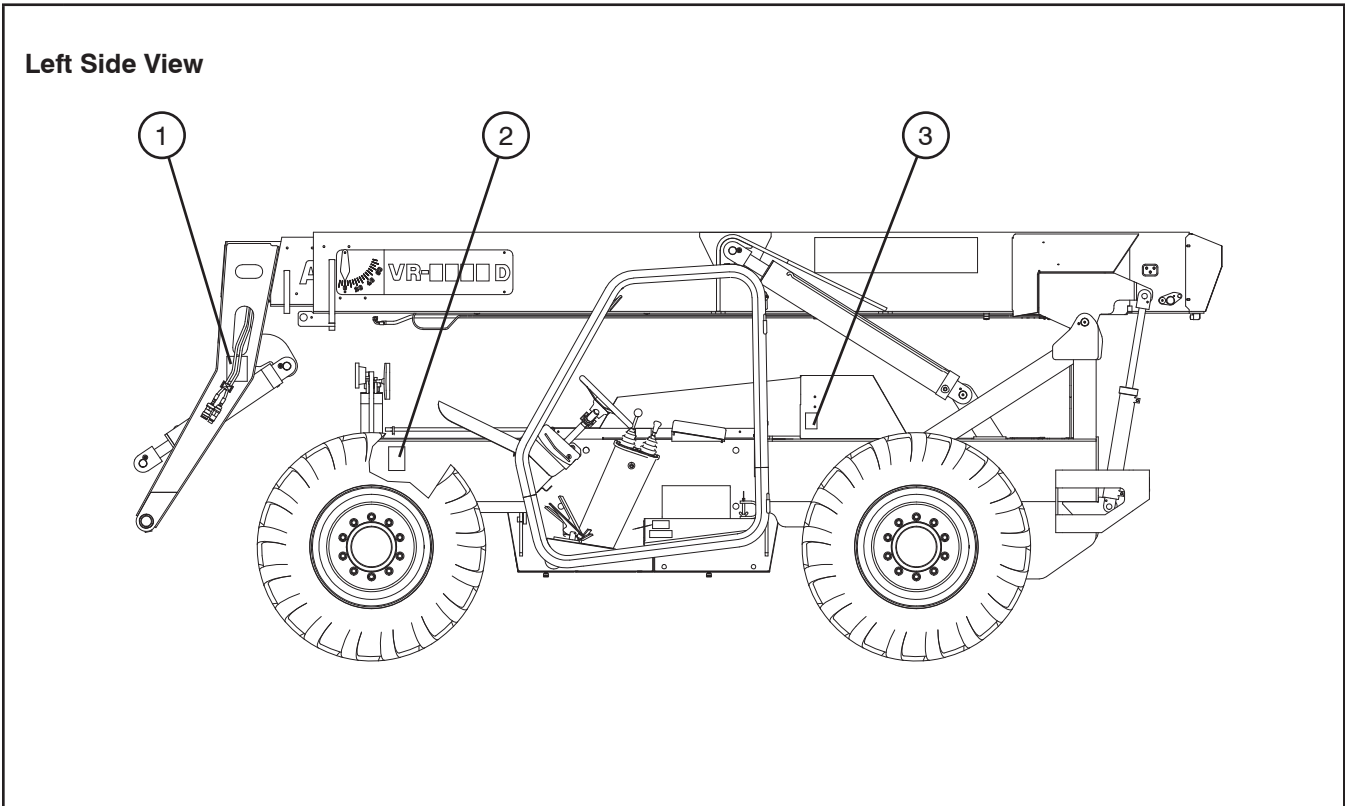



No.	Label Pictorial	Description
6		Improper Operation Operational warning
7		Rollover Tire Inflation Rollover tire inflation warning
8		Block Axle Frame Block axle frame warning
9		Carriage Carriage shift warning
10		Rotating Fan Rotating fan warning
11		Runover Machine runover warning
12		Hydraulic Oil Level Hydraulic oil level indicator

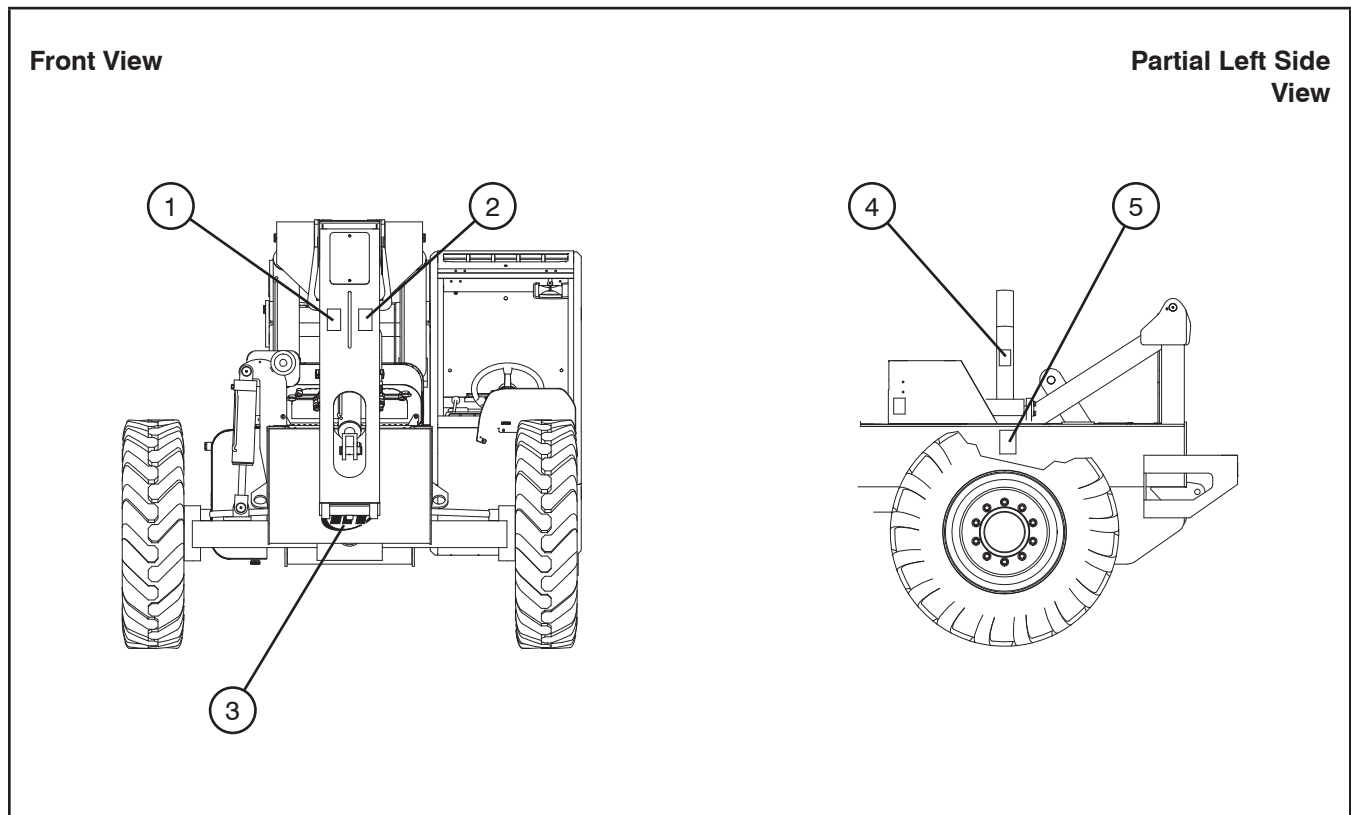





No.	Label Pictorial	Description
1		<p>Carriage</p> <p>Carriage shift warning</p>
2		<p>Crush Area</p> <p>Crush area warning</p>
3		<p>Rotating Fan</p> <p>Rotating fan warning</p>

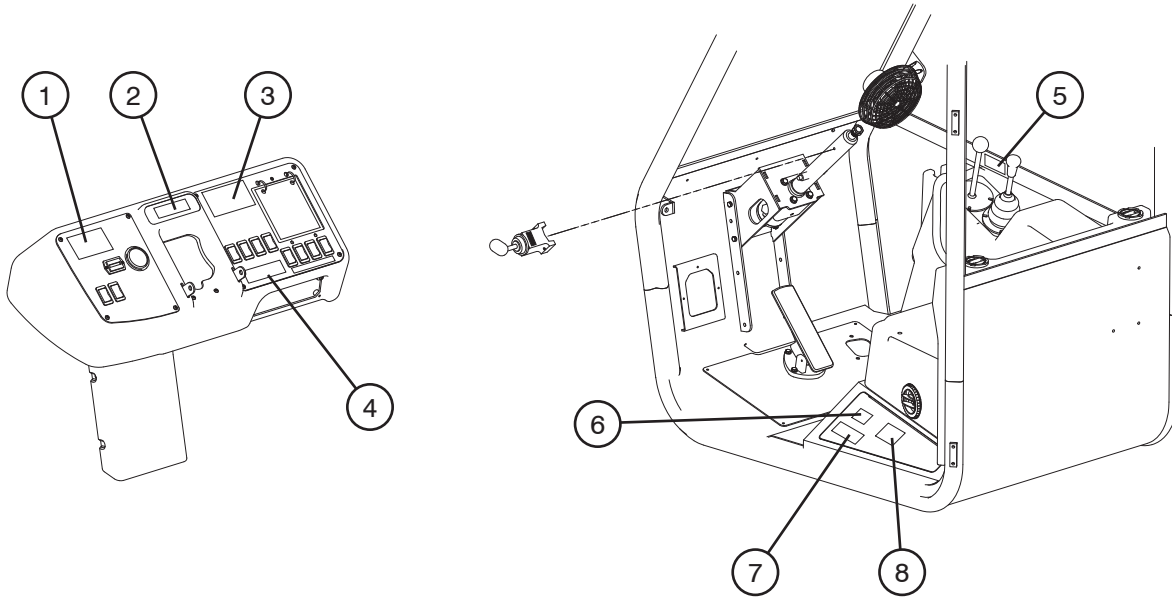

No.	Label Pictorial	Description
1		<p>Falling Load Falling load warning</p>
2		<p>Falling Off Falling from forks warning</p>
3		<p>Skyjack Skyjack logo</p>
4		<p>Block Axle Frame Block axle frame warning</p>
5		<p>Crush Area Crush area warning</p>





Operator's Cab Labels

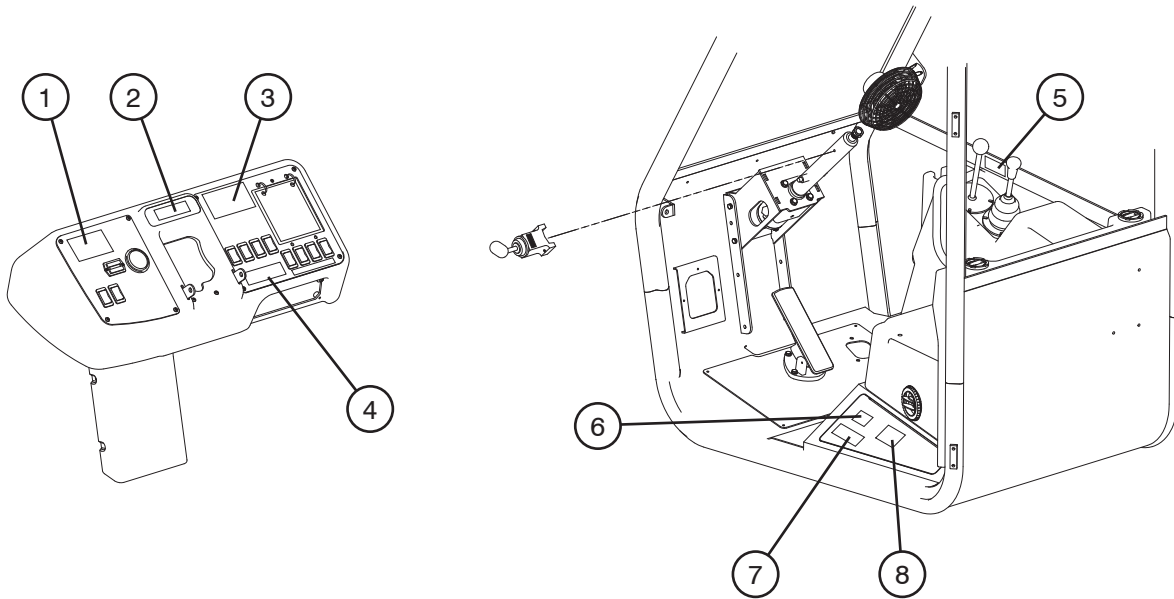

No.	Label Pictorial	Description
1		<p>Rollover</p> <p>Rollover warning</p>
2		<p>Electrical Hazard</p> <p>Electrical hazard warning</p>
3		<p>Unpinned Attachment</p> <p>Unpinned attachment warning</p>
4		<p>Frame Level</p> <p>Frame level left or right</p>

Operator's Cab
Labels - Continued



No.	Label Pictorial	Description
5		<p>Frame Level</p> <p>Frame leveling warning</p>
6		<p>Improper Operation</p> <p>Operational warning</p>
7		<p>OSHA</p> <p>OSHA notice</p>
8		<p>No Riders</p> <p>No riders warning</p>

California Proposition 65



WARNING

Engine exhaust and some of its constituents are known to the State of California to cause cancer, birth defects, and other reproductive harm.

Battery posts, terminals, and related accessories contain lead and lead compounds, chemicals known to the State of California to cause cancer, birth defects, and other reproductive harm.

WASH HANDS AFTER HANDLING.



Reliable lift solutions by people who care.

www.skyjack.com